



STANDARD HORIZON®

Color GPS Chart Plotters

CP180/CP180i

CP300/CP300i

Owner's Manual



CP300/300i



CP180/180i

MAX
C-MAP NT

WARNING!!!

Electronic charts displayed by the GPS Chart Plotter are believed to be accurate and reliable, but are not intended to be a substitute for the official charts, which should remain your main reference for all matters related to the execution of safe navigation.

For this reason we would like to remind you that you should carry on board and use the official published and approved nautical charts.



FCC Compliance Statement

This device complies with Part 15 of the FCC limits for Class A digital devices. This equipment generates, uses, and can radiate radio frequency energy and, if not installed or used in accordance with the instructions may cause harmful interference with radio communications.

There is no guarantee that interference will not occur in a particular instance. If this equipment does cause harmful interference to other equipment, try to correct the problem by relocating the equipment.

Consult an authorized STANDARD HORIZON dealer or other qualified service technician if the problem cannot be corrected. Operation is subject to the following conditions: (1) This device cannot cause harmful interference, and (2) this device must accept any interference received, including interference that may cause undesired operation.

CAUTION

- The GPS Chart Plotter is designed for maritime use. To avoid water intrusion ensure the C-MAP BY JEPPESEN C-CARD door is completely closed.
 - Extensive exposure to heat may result in damage to the GPS Chart Plotter.
 - The GPS Chart Plotter contains dangerous high voltage circuits which only experienced technicians can handle.
 - STANDARD HORIZON will not be liable for errors contained herein, or for incidental or consequential damages in connection with the performance or use of this material.
-

CLEANING PROCEDURE FOR THE GPS CHART PLOTTER SCREEN

Cleaning of the GPS Chart Plotter screen is a very important operation and must be done carefully. Since the surface is covered by a antireflective coating, the procedure for cleaning all the surfaces can be performed using the following procedure: You need a tissue or lens tissue and a cleaning spray (Windex) containing Isopropanol (a normal spray cleaner sold for the PC screen, for example PolaClear by Polaroid). Fold the tissue or lens tissue into a triangular shape, moisten the tip and use the index finger behind a corner to move the tissue across the surface, in overlapping side to side strokes. If the tissue is too wet, a noticeable wet film will be left in its path and you will need to repeat the process. If too dry, the tissue won't glide easily, and may damage the surface.

TABLE OF CONTENTS

1. INTRODUCTION	11
1.0 GENERAL INFORMATION	11
1.1 PACKING LIST	12
1.1.0 CP180/CP180i Packing List	12
1.1.1 CP300/CP300i Packing List	12
1.2 OPTIONAL ACCESSORIES	13
1.3 RADAR UNIT SUPPLIED BY SI-TEX USA	13
2. GETTING STARTED	15
2.0 MOUNTING THE GPS CHART PLOTTER	15
2.1 BRACKET MOUNTING	15
2.2 CP180 AND CP300 FLUSH MOUNTING	16
2.3 MOUNTING THE CP180 OR THE CP300 EXTERNAL GPS ANTENNA	16
2.3.0 Flush mounting the antenna	17
2.4 CONNECTIONS	18
2.4.0 Connection Table For CP180/CP180i	18
2.4.1 Connection Table For CP300/CP300i	19
2.4.2 Connection For CP180/CP180i	20
2.4.3 Connection For CP300/CP300i	22
2.5 BATTERY CONNECTIONS	23
2.6 NMEA CONNECTIONS	23
2.7 GPS POSITION ON A VHF RADIO	24
2.8 OPTIONAL BLACK BOX FISH FINDER	24
2.9 RADAR ANTENNA (USA ONLY)	24
2.10 PERSONAL COMPUTER CONNECTIONS	25
2.11 NMEA DATA PAGE	25
2.12 CP300/CP300i VIDEO INPUT	26
2.12.0 Video Camera Input	26
2.12.1 VCR or DVD Input	26
2.13 DEMO MODE (For DEALER USE)	28
3. CONTROLS AND INDICATORS	29
3.0 CONTROLS AND CONNECTIONS	29
3.0.0 The CP300/CP300i Soft Keys	30
3.1 GETTING STARTED	30
3.1.0 Power On, Off and ShuttlePoint knob operation	30
3.1.1 Cursor Vs. Home mode	31
3.1.2 Cursor and Menu selection speed	32
3.1.3 Changing the Ship Icon	32
3.1.4 Changing the backlight and contrast	33
3.1.5 Selecting North Up or Course Up	33
3.2 AUTOMATIC TIME	34
3.3 SELECTING LORAN TD OR OTHER COORDINATE SYSTEM	35
3.4 CHANGING THE CHART COLOR	35
3.5 SELECTING LANGUAGE	36
3.6 SELECTING PAGES USING SOFT KEYS ON CP300/CP300i	37
3.7 CUSTOMIZING THE SOFT KEYS ON CP300/CP300i	37

3.8	OTHER SETTINGS IN GENERAL SETUP MENU	38
3.9	INFORMATION PAGE	39
4.	FIND SERVICES	41
4.0	USING FIND SERVICES & MORE FUNCTIONS	41
4.0.0	Port Services	41
4.0.1	Port	42
4.0.2	Tide Stations	42
4.0.3	Wrecks	43
4.0.4	Obstructions	44
4.0.5	Lakes Information	45
4.0.6	Lakes By Name	47
4.0.7	Points Of Interest	47
4.0.8	User Points	48
4.0.9	Coordinates	48
4.0.10	Information	49
5.	MAX CARTOGRAPHY OVERVIEW	51
5.0	INSERTING THE C-CARD	51
6.	MAP FUNCTIONS	53
6.0	MAX FUNCTIONS MENU	53
6.0.0	Zoom Type	53
6.0.1	Icons Size	54
6.0.2	Place Names Size	54
6.0.3	Perspective View	55
6.0.4	Dynamic Nav-Aids	56
6.0.5	Safety Status Bar (DSI - Data Safety Indicator)	56
6.0.6	Satellite Imagery	57
6.0.7	Currents Prediction	58
6.0.8	Chart Language	59
6.0.9	Pictures & Diagrams	59
	How to show the pictures or diagrams of a Multimedia Object	60
6.0.10	Enhanced Port Info	61
7.	CREATING MARKS	63
7.0	CREATING A NEW MARK USING THE CHART PAGE	63
7.1	EDITING A MARK	63
7.1.0	Deleting a Mark or Waypoint	64
7.1.1	Moving a Mark or Waypoint	64
7.2	MARKS/WAYPOINTS LIST	65
7.3	CREATING A NEW MARK WITH THE USER POINTS LIST	66
7.4	GOTO CURSOR, ROUTE AND MARK	67
8.	MAN OVER BOARD (MOB) FUNCTION	69
8.0	PLACING A MOB POINT	69
8.1	DELETING A MOB POINT	69
9.	ROUTES	71
9.0	CREATING A ROUTE USING WAYPOINTS	71
9.1	CHANGING NAME TO A ROUTE	71
9.2	CREATING AN OLYMPIC ROUTE	72
9.3	MAKING ADDITIONAL ROUTES	73

9.4	CREATING A ROUTE USING MARKS ON THE CHART PAGE	73
9.5	INSERTING A WAYPOINT INTO A ROUTE	73
9.6	GOTO A ROUTE	74
9.6.0	By select Route	74
9.6.1	By Cursor key	75
9.7	DELETING A ROUTE	75
9.8	OTHER SETTINGS IN ROUTE MENU	75
9.8.0	Route Check	76
10.	TRACKS	79
10.0	TRACKING	79
10.0.0	Saving and starting a new Track	80
10.0.1	Other Settings in Track Menu	80
10.1	USING THE TRIP LOG	80
10.1.0	Trip Log selection / Reset	81
11.	USER C-CARD	83
11.0	USER C-CARD MENU	83
11.0.0	Formatting the User C-CARD	83
11.0.1	Transferring files to the optional User C-CARD	83
11.0.2	Loading a file	84
11.0.3	Deleting a file from the User C-CARD	84
11.0.4	Refreshing the User C-CARD	84
12.	PAGES	85
12.0	CHART PAGE	86
	For CP300/CP300i Focus Soft Key on Dual Chart page	87
	For CP180/CP180i Change Focus on Dual Chart page	87
	Single Chart page	88
12.0.0	Window Selections	88
12.0.1	Customizing the Data Windows	88
12.0.2	Additional Functions on Chart page	90
12.0.3	Turning Off Information on Icon Points	90
12.0.4	Display Mode	90
12.0.5	Marine Settings	91
12.0.6	Depth Settings	92
12.0.7	Land Settings	92
12.0.8	Chart Settings	93
12.0.9	Underwater Objects Settings	94
12.1	CUSTOMIZING CHART SETTINGS	94
12.2	NAVIGATION PAGE	95
12.3	HIGHWAY PAGE	96
12.4	CELESTIAL PAGE	96
12.5	GPS STATUS PAGE	97
12.5.0	WAAS/EGNOS Setting	97
12.5.1	GPS Setup Menu	98
12.6	NMEA DISPLAY PAGE	98
12.7	NMEA DATA PAGE	99
12.8	NMEA TREND PAGES	100
12.9	VHF DIGITAL SELECTIVE CALLING	101
12.9.0	Interfacing	101
12.9.1	DSC Distress Call	102
12.9.2	Position Request	102

13. ADVANCED SETTINGS	103
13.0 INPUT/OUTPUT (NMEA)	103
13.1 NAVIGATE	103
13.1.0 Loran TD	104
13.2 COMPASS	104
13.3 ALARMS	104
13.4 SIMULATION	105
13.4.0 Navigating a Route in Simulation mode	106
13.5 DSC POLLING	106
14. AIS	107
14.0 AIS SYSTEM DEFINITIONS	107
14.1 AIS MENU	108
14.2 TO SET THE CHART PLOTTER FOR RECEIVING AIS	108
14.3 QUICK INFO ON AIS TARGET	109
14.4 AIS LIST	109
15. C-WEATHER SERVICE	111
15.0 C-WEATHER SERVICE MENU	111
15.0.0 Download	111
15.0.1 Copy From User C-CARD	112
15.0.2 Weather Forecast	112
15.0.3 Real Time View	112
15.0.4 Type of Data	112
16. MOBILARM	113
16.0 MOBILARM-GPS CHART PLOTTER CONNECTION	113
16.1 SOFTWARE SETUP	114
16.2 MOBILARM STATUS	114
16.3 MOBILARM PTX	115
16.3.0 MOBILARM MOB alert is received	115
16.4 PLACING CURSOR ON THE PTX ICON	116
16.4.0 Delete PTX	117
16.4.1 Goto PTX	117
16.4.2 The MOBILARM Alarm Status List	118
17. TROUBLESHOOTING	121
18. TECHNICAL TESTS	123
18.0 SYSTEM TEST	123
18.0.0 RAM Menu (reset)	123
18.0.1 DIM Menu	123
18.0.2 Cartridges	124
18.0.3 Serial Ports	124
19. SPECIFICATIONS	125
19.0 CP180/CP180i SPECIFICATIONS	125
19.1 CP300/CP300i SPECIFICATIONS	126
19.2 OPTIONAL WAAS GPS RECEIVER SPECIFICATIONS	127
20. APPENDIX: TERMS	129
ANALYTICAL INDEX	133

1. INTRODUCTION

Congratulations on your purchase of the Standard Horizon GPS Chart Plotter. Whether this is your first GPS Chart Plotter, or if you have other STANDARD HORIZON equipment, the STANDARD HORIZON organization is committed to ensuring your enjoyment of this GPS Chart Plotter. STANDARD HORIZON technical support personnel stand behind every product we sell, and our Product Support team invites you to contact us should you require technical advice or assistance, at 800/767-2450, or marinetech@vxstdusa.com.

1.0 GENERAL INFORMATION

The CP180, CP300 (with external GPS antenna) and CP180i, CP300i (with internal GPS antenna) are precision-crafted GPS Chart Plotters with high-performance receiver for the Global Positioning System (WAAS GPS) constellation of satellites, providing precise location data with a host of navigation features. Ideal for nautical use and sealed against water ingress. The GPS Chart Plotter is housed in a rugged, impact-resistant case with outstanding ergonomic design, for effortless operation.

The advanced features of the GPS Chart Plotter include:

- Direct sunlight viewable color LCD display
- CP180i/CP300i - Internal 50 Channel WAAS GPS
- Capable of using the Optional FF525 (or FF520) 50/200kHz BLACK BOX FISH FINDER
- Capable of using a RADAR Antenna (USA ONLY)
- C-MAP BY JEPPESEN NT*/MAX cartography compatible
- Improved Worldwide background showing detail up to 2.0 NM
- CP180/CP300 - WAAS GPS antenna, bracket and flush mounting hardware
- CP300/CP300i - Video Input with "picture-in-picture" display
- Dual chart window with independent zoom levels
- Satellite images on base map
- Route Check
- Dedicated AIS List page
- Navigate to an Olympic Route
- 3000 Marks / 50 Routes / 10000 Track points
- User selectable data fields
- NMEA Data pages
- CP180/CP180i - 3 NMEA Outputs and 2 Inputs (2 Inputs For CP180i)
CP300/CP300i - 5 NMEA Outputs and 3 Inputs (2 Inputs For CP300i)
- Connections to and from STANDARD HORIZON compatible DSC VHF's for Distress and Position Request calls
- 3 year limited warranty, lifetime flat rate

NOTE

The screen images on this manual refer to the CP180/CP180i Chart Plotters unless specified.

1.1 PACKING LIST

When the package containing the GPS Chart Plotter is first opened, please check for the following contents.

If any parts are missing contact the dealer this GPS Chart Plotter was purchased from. Accessories and replacement parts may be ordered from STANDARD HORIZON's Parts Department at (800)767-2450 ext 6800 or e-mail at yaesuparts@vxstdusa.com.

1.1.0 CP180/CP180i Packing List

PART CODE	ITEM
S8002224A	External bracket
S8002225	Mounting knob with two washers
S8002222	Dust cover
T9101553	Power data cable
S8002223	Flush mounting screws (CP180 ONLY)
EM016N550	Flush mount template (CP180 ONLY)
Q7000619A	GPS ANT Unit GSU-5H Series UX0GSU51SD* (CP180 ONLY)
EM022U106	Owner's Manual
EM023U510	Quick Reference Guide







NOTE: "*" is a revision number

1.1.1 CP300/CP300i Packing List

PART CODE	ITEM
S8002224A	External bracket
S8002225	Mounting knob with two washers
S8002235	Dust cover
T9101553	PWR & ACC 1 cable
T9101553	ACC 2 cable
S8002223	Flush mounting screws (CP300 ONLY)
EM022U500	Flush mount template (CP300 ONLY)
XUCMP0052	2 Amp fuse and holder
Q7000619A	GPS ANT Unit GSU-5H Series UX0GSU51SD* (CP300 ONLY)
EM022U106	Owner's Manual
EM023U510	Quick Reference Guide

NOTE: "*" is a revision number

1.2 OPTIONAL ACCESSORIES

ACCESSORIES	PARTS NAME	ITEM
	ACVC10	Video Adapter cable (AAF69X001) (CP300/CP300i ONLY)
	FF525	50/200kHz Black Box Fish Finder
	DST520	600W 2" Nylon Thru-hull depth temp Transducer
	DST521	600W Transom mount depth, speed temp Transducer
	DST523	600W 2" Bronze Thru-hull depth temp Transducer
	DST525	600W In-hull Transducer
	DST526	600W 2" Bronze Thru-hull depth, speed temp Transducer
	DST527	1000W In-hull depth Transducer
	DST528A	1000W Bronze long stem depth temp Transducer

1.3 RADAR UNIT SUPPLIED BY SI-TEX USA

The Radar antenna will be supplied by SI-TEX in USA only and the part code is as follows:

MODEL NUMBER	DESCRIPTION
MDS-1	2kW 24 Mile 12.4" diameter Radome antenna
MDS-8	2kW 24 Mile 20" diameter Radome antenna
MDS-9	4kW 36 Mile 23.5" diameter Radome antenna
MDS-10-4	4kW 48 Mile 4FT Open Array
MDS-10-5	4kW 48 Mile 5FT Open Array

NOTE

Please contact to the Standard Horizon Authorized dealer, STANDARD HORIZON product technical support or SI-TEX directly for additional information.

2. GETTING STARTED

NOTE

Throughout this Owner's Manual same conventions are used. See the legend below:

[MENU] If you see brackets around a bold and capital letter word this refers to a key press.

[CHART] If you see brackets around a bold and small capital letter word this refers to a Soft Key press.

GENERAL SETUP When a word(s) is bold capital letters and underlined, this refers to a menu selection item.

2.0 MOUNTING THE GPS CHART PLOTTER

The CP180 and CP300 are supplied with hardware for bracket or flush mounting, the CP180i and CP300i are supplied with the hardware for bracket mounting due to the internal design of the GPS antenna. Below are pictures showing actual examples of the two types of installation.

NOTE

The GPS Chart Plotter with internal GPS antenna is designed to be bracket mounted only. Do not flush mount or GPS performance may be dramatically reduced or not receive a fix.

2.1 BRACKET MOUNTING

The CP180/CP180i and CP300/CP300i can be mounted using the supplied swivel mounting bracket. Before installing ensure the area the bracket is mounted to is strong enough to support the weight of the GPS Chart Plotter especially while under way. After the location is found, attach the mounting base to the area using the supplied hardware.

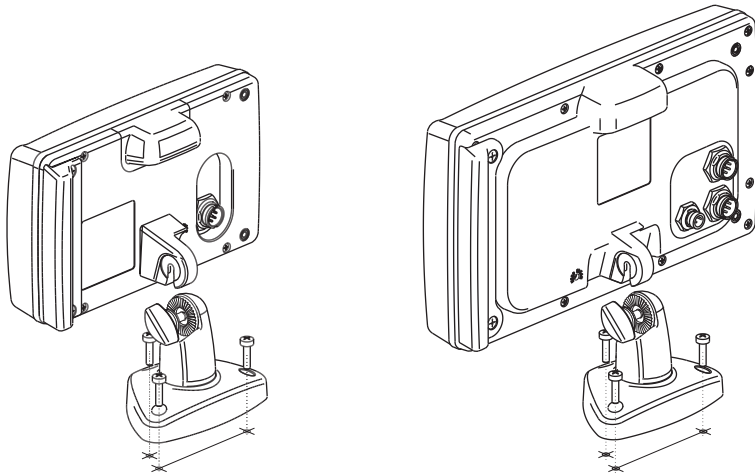

Figure 2.1 - Example of Bracket installation (CP180i on the left side and CP300i on the right side)

2.2 CP180 AND CP300 FLUSH MOUNTING

The CP180 and CP300 are supplied with a flush mount template for the cutout hole and screw holes required to install the GPS Chart Plotter.

NOTE

Before drilling holes make sure there is enough room to mount the GPS Chart Plotter and there are no obstructions.

1. After a location is found, peel the template label from the backing and apply the label to the mounting area.
2. Drill a hole in one area of the cutout area that will allow the blade of a jig saw to be inserted. Insert and cut out the area on the panel using the jig saw.
3. Next drill the four holes required to insert the GPS Chart Plotter with the mounting studs.
4. Install the mounting studs on the GPS Chart Plotter and insert into the mounting hole.
5. Attach the GPS Chart Plotter to the mounting location by attaching the supplied hardware to the mounting studs.

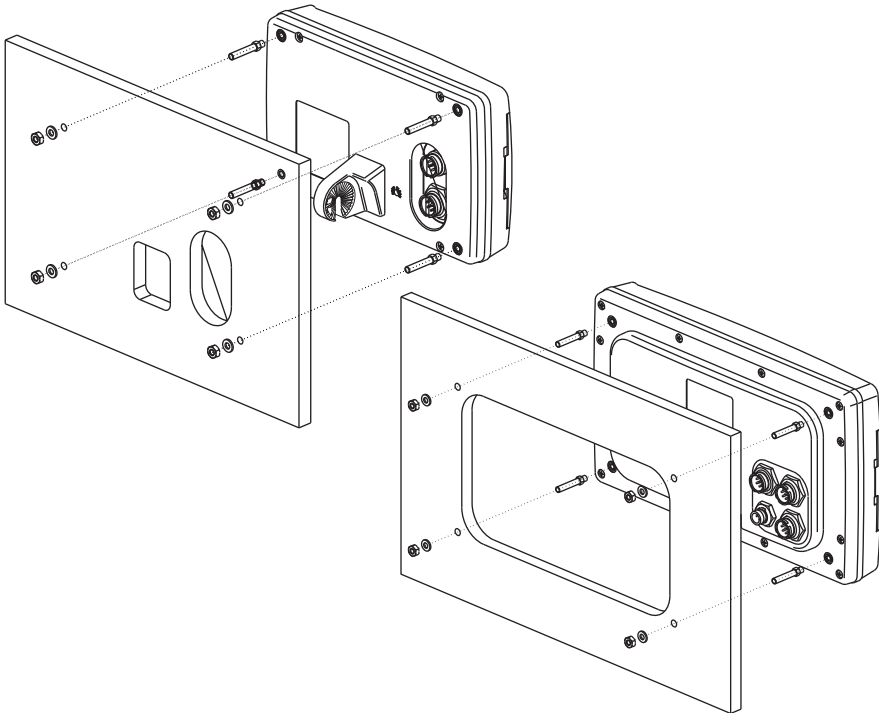

Figure 2.2 - Example of Flush installation (CP180 on the left side and CP300 on the right side)

2.3 MOUNTING THE CP180 OR THE CP300 EXTERNAL GPS ANTENNA

The CP180 and CP300 are supplied with an external WAAS GPS antenna with 15 meter

of routing cable. This antenna is designed to be mounted on a base, installed on an extension or even flush mounted.

Choose a location for the antenna that has a clear view of the sky and is not located within 3FT of Radar or other transmitting antennas. Ensure there are no major obstructions or fixtures in the immediate proximity to the antenna. The antenna relies on direct “line of sight” satellite reception. If you are unsure of the chosen location, temporarily mount the antenna in the desired location to verify correct operation. If mounted close to Radar, after the GPS Chart Plotter has a fix, turn on the Radar to ensure the GPS Chart Plotter holds the fix (use the GPS Status Page).

The thread used on the antenna is an industry standard (1inch 14TPI) used on a wide range of mounting brackets.

NOTE

The antenna cable can be cut and spliced to ease installation. Care must be taken when reconnecting the antenna cable to protect from water and corrosion.

2.3.0 Flush mounting the antenna

NOTE

Before drilling holes, it is recommended the antenna be positioned where the location is planned, cable connected to the GPS Chart Plotter and power turned on to ensure a GPS Fix is received.

1. Remove the threaded base from the antenna dome.
2. To ease installation a flush mounting template for the antenna has been included.
3. Apply the mounting template sticker to the area that was verified for GPS reception.
4. Then, drill out the 0.31” (8mm) and 0.13” (3.2mm) holes, and remove the template.
5. Insert the cable into the 0.31” (8mm) hole and route to the GPS Chart Plotter.
6. Apply a small amount of RTV to the under side of the antenna.
7. Place the antenna and then screw it into place using the screws.

NOTE

In some cases the screw may not be long enough, if this happens simply apply more RTV to the underside of the antenna to glue it into place.

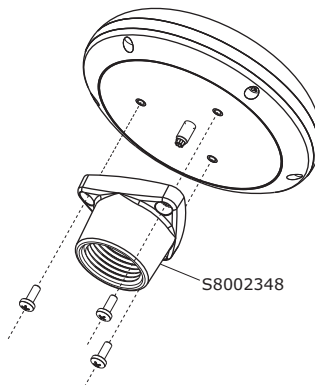

Figure 2.3.0 - Installing the External GPS Antenna (I)

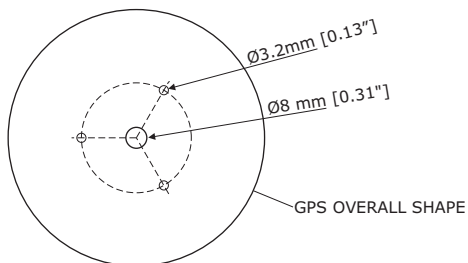

Figure 2.3.0a - Installing the External GPS Antenna (II)

Smart GPS Cable FOR CP180/CP180i AND CP300/CP300i

Pin	Wire Color	Description
1	Red	Battery Positive
2	Green	Smart GPS NMEA Output
3	Brown	Smart GPS NMEA Input
4		NC
5		NC
6	Black/Yellow	Battery Ground

2.4 CONNECTIONS

The GPS Chart Plotter has connectors that are used to connect to the power supply, GPS Antenna (CP180 AND CP300 ONLY), optional FF525 (or FF520) 50/200kHz BLACK BOX FISH FINDER and to NMEA devices such as VHF's, AIS Receivers, digital instruments and autopilots.

NOTE

The GPS Chart Plotter can send many sentences to external NMEA devices. The NMEA Output wires are Yellow, Brown and White. If you have connected devices as shown in the below table and need to feed NMEA to other devices (Autopilot, RADAR...) you can parallel wires from the Yellow, Brown or White wires.

2.4.0 Connection Table For CP180/CP180i

12VDC Power and NMEA PWR & ACC 1 Cable

Pin	Wire Color	Description	Connection Example	Additional Comments
1	Black	Battery Ground	Connect to Battery Ground	
2	Red	Battery Positive	Connect to Battery Positive	
3	Green	NMEA Common	Common (ground) for NMEA devices	
4	Blue	Port1 Input	Connect to Output of NMEA device	Default is NMEA0183*
5	Brown	Port1 Output	Connect to Input of NMEA device	Default is NMEA0183 with GGA, GLL, RMC, DBT, DPT, MTW, VHW and XTE sentences
6	Grey	Port2 Input	Connect to FF520 or FF525	Default is Fish Finder
7	White	Port2 Output	Connect to FF520 or FF525	Default is Fish Finder
8	Yellow	Port3 Output	Connect to Output of NMEA device	Default is NMEA0183 with APA, APB, BOD, GGA, GLL, RMC and BOD sentences**

*NOTE: AIS RECEIVER OPTION

When an optional AIS receiver is connected, Port1 (or other Port the AIS is connected to) of the NMEA In/Out Connections menu must be changed to AIS 38400 as shown below for communications. When AIS 38400 is selected the Output Port is disabled.

1. From the Chart page, press **[MENU]**. Move the ShuttlePoint knob to highlight **SETUP MENU** and press **[ENT]**.
2. Move the ShuttlePoint knob to highlight **ADVANCED SETUP** and press **[ENT]** or move the ShuttlePoint knob to the right.
3. Move the ShuttlePoint knob to highlight **IN/OUT CONNECTIONS** and press **[ENT]** or move the ShuttlePoint knob to the right.
4. Move the ShuttlePoint knob to highlight **PORT1 INPUT** (or other Port the AIS is connected to) and press **[ENT]** or move the ShuttlePoint knob to the right.
5. Move the ShuttlePoint knob up/down to select **AIS 38400** and press **[ENT]** or move the ShuttlePoint knob to the right.
6. Press **[CLR]** or move the ShuttlePoint knob to the left until the Chart page is shown.

****NOTE: AUTOPILOT CONNECTION**

Care must be taken when connecting the GPS Chart Plotter to an Autopilot. Normally Port3 (Yellow wire) will be used to connect to an Autopilot Input, however older Autopilots may not be able to read the sentences due to the talker ID that is being used (II Integrated Instrument). If the Autopilot connections are made to Port3 (Yellow wire) and the Autopilot is not reading the sentences, change the connections to Port1 (Brown) or 2 (White) and change the sentences to APA, APB, BOD, GGA, GLL, RMC and XTE.

2.4.1 Connection Table For CP300/CP300i

12VDC Power and NMEA PWR & ACC 1 Cable

Pin	Wire Color	Description	Connection Example	Additional Comments
1	Black	Battery Ground	Connect to Battery Ground	
2	Red	Battery Positive	Connect to Battery Positive	
3	Green	NMEA Common	Common (ground) for NMEA devices	
4	Blue	Port 1 Input	Connect to Output of NMEA device	Default is NMEA0183
5	Brown	Port 1 Output	Connect to Input of NMEA device	Default is NMEA0183 with GGA, GLL, RMC, XTE, DBT, DPT, MTW, VHW sentences
6	Grey	Port2 Input	Connect to FF520 or FF525	Default is Fish Finder
7	White	Port2 Output	Connect to FF520 or FF525	Default is Fish Finder
8	Yellow	Port 3 Output	Connect to Output of NMEA device	Default is NMEA0183 with APA, APB, BOD, GGA, GLL, RMC and BOD sentences

NMEA ACC 2 Cable

Pin	Wire Color	Description	Connection Example	Additional Comments
1	Black	NC		
2	Red	NC		
3	Green	NMEA Common	Common (ground) for NMEA devices	
4	Blue	Port 4 Input	Connect to Output of NMEA device	Default is NMEA0183*
5	Brown	Port 4 Output	Connect to Input of NMEA device	Default is NMEA0183 with GLL, RMB, RMC and XTE sentences
6	Grey	Port 5 Input	Connect to Output of NMEA device	Default is NMEA0183
7	White	Port 5 Output	Connect to Input of NMEA device	Default is NMEA0183 with GLL, RMB, RMC and XTE sentences
8	Yellow	NC		

***NOTE: AIS RECEIVER OPTION**

When an optional AIS receiver is connected, Port4 (or other Port the AIS is connected to) of the NMEA In/Out Connections menu must be changed to AIS 38400 as shown below for communications. When AIS 38400 is selected the Output Port is disabled.

1. From the Chart page, press **[MENU]**. Move the ShuttlePoint knob to highlight **SETUP MENU** and press **[ENT]**.

2. Move the ShuttlePoint knob to highlight **ADVANCED SETUP** and press [ENT] or move the ShuttlePoint knob to the right.
3. Move the ShuttlePoint knob to highlight **IN/OUT CONNECTIONS** and press [ENT] or move the ShuttlePoint knob to the right.
4. Move the ShuttlePoint knob to highlight **PORT4 INPUT** (or other Port the AIS is connected to) and press [ENT] or move the ShuttlePoint knob to the right.
5. Move the ShuttlePoint knob up/down to select **AIS 38400** and press [ENT] or move the ShuttlePoint knob to the right.
6. Press [CLR] or move the ShuttlePoint knob to the left until the Chart page is shown.

Video Connector

Pin	Description	Connection Example
1	Ground	Connect to Video Signal Ground of DVD/VCR/Video Cameras
2	+ 9 / 12 VDC	Connect to Video Cameras Power Input
3	Video Signal +	Connect to Video Signal + (NTSC/PAL) of DVD/VCR/Video Cameras

2.4.2 Connection For CP180/CP180i

2.4.2.1 DC Power Connection

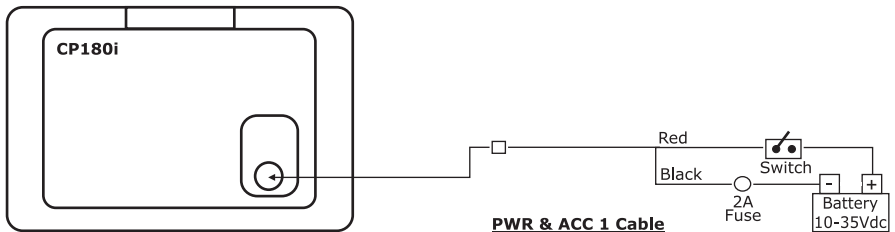
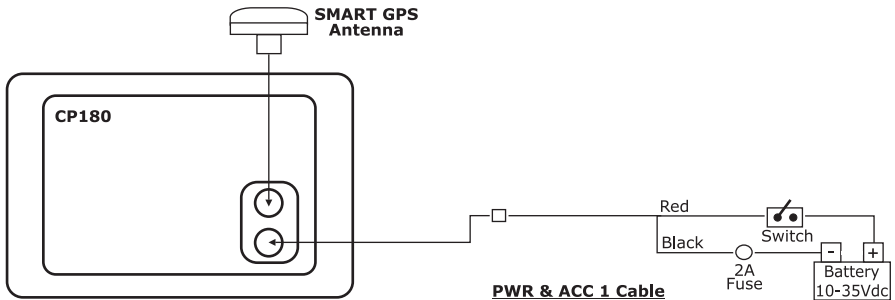

2.4.2.2 Connection of the FF525 (or FF520), AIS receiver, VHF and Autopilot

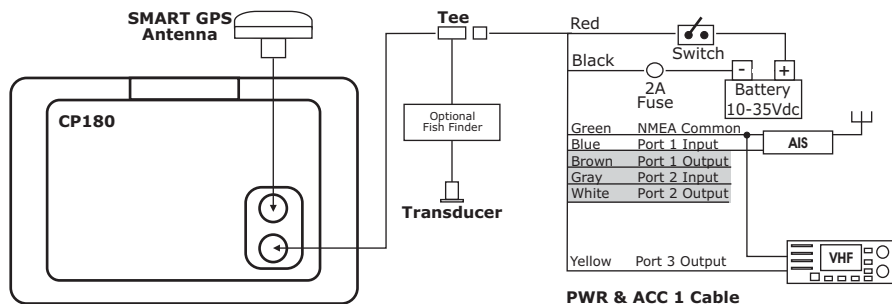
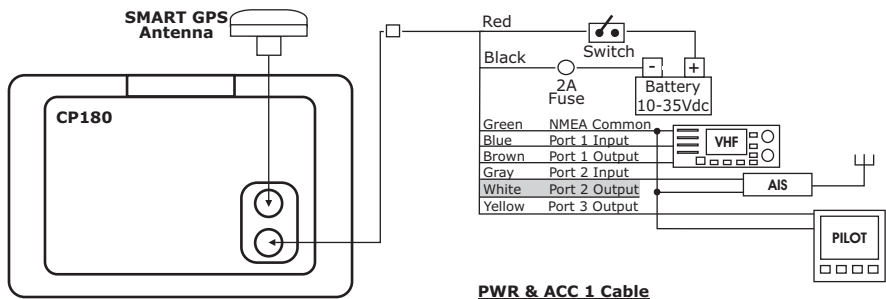

NOTE

Port2 Input and Output is used by the optional FF525 (or FF520). In the diagram above you will notice Port2 Input and Output wires are shown in gray and not used.

AIS Setup

The CP180 or CP180i has to be setup to be able to receive NMEA information from the AIS receiver.

1. Press **[MENU]**, move the ShuttlePoint knob to highlight **SETUP MENU** and press **[ENT]**.
2. Move the ShuttlePoint knob to highlight **ADVANCED SETUP** and press **[ENT]** or move the ShuttlePoint knob to the right.
3. Move the ShuttlePoint knob to highlight **IN/OUT CONNECTIONS** and press **[ENT]** or move the ShuttlePoint knob to the right.
4. Move the ShuttlePoint knob to highlight **PORT1 INPUT** and press **[ENT]** or move the ShuttlePoint knob to the right.
5. Move the ShuttlePoint knob up/down to select **AIS 38400** and press **[ENT]** or move the ShuttlePoint knob to the right.

NOTE

If an AIS receiver is not connected, Port1 Input can be connected to most DSC VHF's for position polling.

2.4.3 Connection For CP300/CP300i

2.4.3.1 DC Power Connection

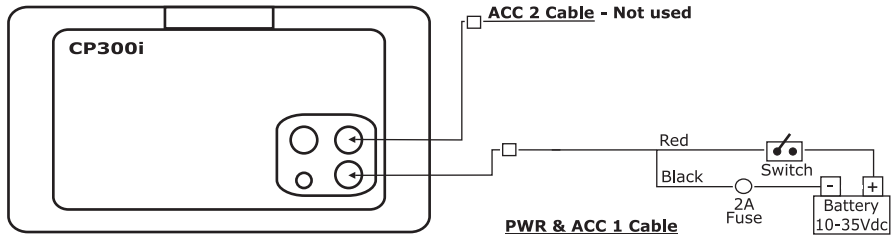
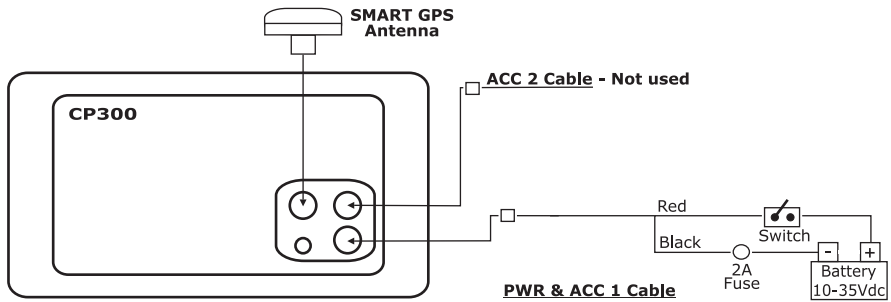

2.4.3.2 Connection a VideoCamera, FF525 (or FF520), AIS receiver, VHF and Autopilot

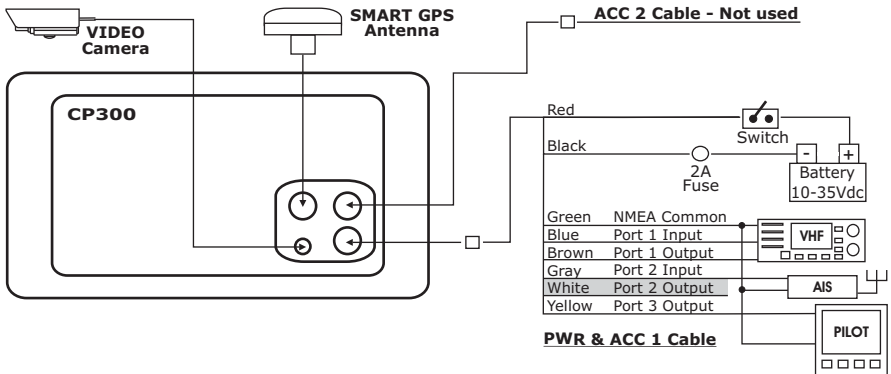

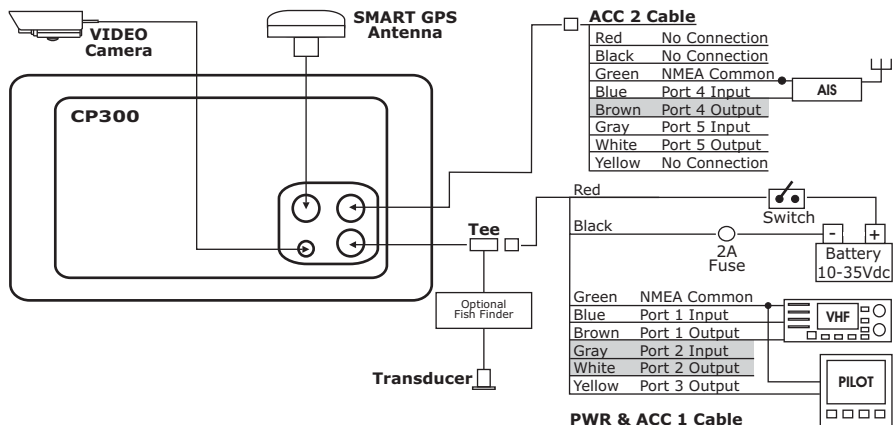

NOTE

Port2 Input and Output is used by the optional FF525 (or FF520). In the diagram above you will notice Port2 Input and Output wires are shown in gray and not used.

Port4, and 5 Outputs are can be connected to NMEA devices capable of listening to NMEA0183 sentences.

Port4, and 5 Inputs can be connected to NMEA devices capable of outputting to NMEA0183 sentences.

The Input and Output baud rate for each Port is set using the Advanced Setup>In/Out Connections menu. For example if Port1 is set for AIS 38400, the Input Port operates at 38400 baud and the Output Port is disabled.

AIS Setup

The CP300 or CP300i has to be setup to be able to receive NMEA information from the AIS receiver.

1. Press **[Menu]**, move the ShuttlePoint knob to highlight **SETUP MENU** and press **[ENT]**.
2. Move the ShuttlePoint knob to highlight **ADVANCED SETUP** and press **[ENT]** or move the ShuttlePoint knob to the right.
3. Move the ShuttlePoint knob to highlight **IN/OUT CONNECTIONS** and press **[ENT]** or move the ShuttlePoint knob to the right.
4. Move the ShuttlePoint knob to highlight **PORT4 INPUT** (or other Port the AIS is connected to) and press **[ENT]** or move the ShuttlePoint knob to the right.
5. Move the ShuttlePoint knob up/down to select **AIS 38400** and press **[ENT]** or move the ShuttlePoint knob to the right.

2.5 BATTERY CONNECTIONS

1. The GPS Chart Plotters are supplied with a fuse and holder. This fuse should be installed into the Black wire to protect the NMEA Output/Input circuits from becoming damaged.
2. Connect the Red and Black wires from the GPS Chart Plotter to a 12VDC source directly as possible.

2.6 NMEA CONNECTIONS

The GPS Chart Plotter can be connected to external devices with NMEA and display information, examples:

- DSC VHF Radio
- Depth Sounder, Speed Log, Wind Instrument, Autopilot etc.
- Radar (USA ONLY)
- Personal Computer
- AIS receiver
- MOBILARM System

2.7 GPS POSITION ON A VHF RADIO

STANDARD HORIZON has pioneered Digital Selective Calling (DSC) on VHF radios. Advancements in DSC have made it possible to show the coordinates of a vessel that has transmitted a DSC Distress Call or even Poll the location of another vessel and show the position of that vessel on the display of STANDARD HORIZON VHF's.

STANDARD HORIZON has taken this feature one step further, if the GPS Chart Plotters are connected to a STANDARD HORIZON DSC capable VHF, the vessel in Distress or the polled position of the vessel is shown on the display of the GPS Chart Plotter, making it easy to navigate to the location of the vessel. This is a great feature that could save someone's life or for anyone wanting to know the position of another vessel.

Other DSC VHF Manufactures

GPS Chart Plotter	Description	VHF
Green	NMEA Common Ground	Connect to NMEA Ground
Brown	NMEA Positive Output	Connect to NMEA Input
Blue	NMEA Positive Input	* Connect to NMEA Output (if available)

* Some manufacturers of DSC VHF's are not capable of receiving NMEA DSC sentences from the GPS Chart Plotter. Refer to the Owner's Manual and confirm the VHF can receive NMEA DSC and DSE sentences output by the Brown wire.

NOTE

Refer to VHF Digital Selective Calling section for operation.

2.8 OPTIONAL BLACK BOX FISH FINDER

STANDARD HORIZON offers an optional BLACK BOX FISH FINDER called the FF525. Please refer to the Owner's Manual supplied with the Fish Finder for connections and operation.



Figure 2.8 - FF525 50/200kHz BLACK BOX FISH FINDER

NOTE

The FF520 is also compatible.

2.9 RADAR ANTENNA (USA ONLY)

Please refer Par. "1.3 Radar Unit supplied by SI-TEX USA". The RADAR Antenna includes the necessary electronics to deliver Radar information to a compatible STANDARD HORIZON

GPS Chart Plotter, and is supplied with mounting hardware kit, interconnection cable and a RADAR Junction Box.

Please refer to the Radar Installation Manual and Radar Operation Manual available at www.standardhorizon.com.

2.10 PERSONAL COMPUTER CONNECTIONS

The GPS Chart Plotter can be connected to output Marks, Routes and Tracks to many PC programs available. To send or receive User Points the PC Program must be able to receive NMEA WPL and RTE sentences. Refer to the table below for connection to a Serial DB9 connector.

Pin	PC DB9 connection	NMEA connection
2	Receive	Brown
3	Transmit	Blue
5	Signal ground	Green

By default Port1 is set to receive or send User Points to and from a PC. The GPS Chart Plotter may be setup to send and receive the User Points on a different Port using the following procedure:

1. Press **[MENU]**. Move the ShuttlePoint knob to highlight **SETUP MENU** and press **[ENT]**.
2. Move the ShuttlePoint knob to highlight **ADVANCED SETUP** and press **[ENT]** or move the ShuttlePoint knob to the right.
3. Move the ShuttlePoint knob to highlight **IN/OUT CONNECTIONS** and press **[ENT]** or move the ShuttlePoint knob to the right.
4. Move the ShuttlePoint knob to highlight **SEND/REC RTE & MARKS** and press **[ENT]** or move the ShuttlePoint knob to the right to show the popup window.
5. Move the ShuttlePoint knob to desired Port and press **[ENT]**.

The PC COM settings are:

- Baud Rate : 4800
- Parity : N
- Data Bits : 8
- Stop Bits : 1
- Flow Control : N

The format of the sentences that are sent:

- MARK \$GPWPL,3249.061,N,00710.651,E,MRK002*22
- WAYPOINT \$GPWPL,3933.008,N,00639.969,E,WPT012*22
- ROUTE \$GPWPL,2544.362,N,08011.672,W,WPT003*32
\$GPWPL,2543.921,N,08011.481,W,WPT004*31
\$GPWPL,2543.493,N,08011.768,W,WPT005*37
\$GPRTE,2,1,c,ROUTE01,WPT003,WPT004,WPT005*21

2.11 NMEA DATA PAGE

The NMEA Data Page is very useful to see if a External device (example: Depth Sounder) is transmitting NMEA sentences to the GPS Chart Plotter. This page can also be used to see if the GPS Chart Plotter NMEA output is being loaded down by a external NMEA device the GPS Chart Plotter is connected to. Example:

VHF Radio connected but the radio is not receiving a GPS Position.

Usually the VHF radio will be connected to the Green and Brown wires. To check to see if the GPS Chart Plotter is transmitting the sentences:

1. Press **[MENU]**. Move the ShuttlePoint knob to highlight **NMEA DISPLAY** and press **[ENT]**.
2. Move the ShuttlePoint knob to highlight **DATA** and press **[ENT]**.
3. The **NMEA DATA** page is shown.
4. Connect the Blue Wire on the GPS Chart Plotter to the junction of the Brown wire and the VHF wire. The display should look similar to the following picture.

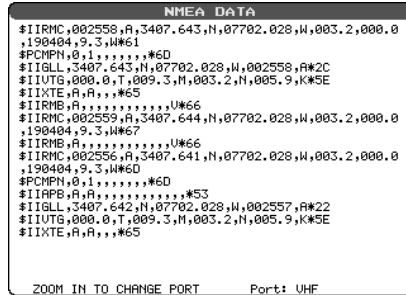

Figure 2.11 - NMEA Data page

2.12 CP300/CP300i VIDEO INPUT

By accessing this menu it is possible to see images on the CP300/CP300i display from an external video signal source, if connected to the CP300/CP300i.

It allows the "picture-in-picture" functionality, so a Video Input image can be shown on a window and placed over the Chart, Navigation, Highway, Celestial and NMEA pages image at full screen.

NOTE

If the Video Input signals is not detected (E.g. the video camera is not connected to the Video Input connector), the VIDEO INPUT menu item will be greyed out.

Video Connector

Pin	Description	Connection Example
1	Ground	Connect to Video Signal Ground of DVD/VCR/Video Cameras
2	+ 9 / 12 VDC	Connect to Video Cameras Power Input
3	Video Signal +	Connect to Video Signal + (NTSC/PAL) of DVD/VCR/Video Cameras

2.12.0 Video Camera Input

The CP300/CP300i has one connection for video camera. Any NTSC or PAL camera will operate correctly. To connect use the video output of the camera and connect to the optional ACVC10 cable.

2.12.1 VCR or DVD Input

A VCR or DVD may be connected to Video port. The CP300/CP300i does not have speakers so the audio from the VCR or DVD would have to be routed to a stereo system.

STANDARD HORIZON offers an optional cable called ACVC10 that allows any VCR or

DVD to simply be plugged into the CP300/CP300i.

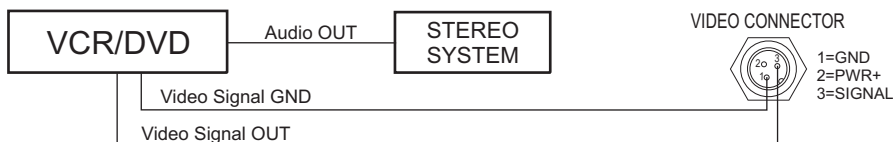

Figure 2.12.1 - VCR/DVD Input

The CP300/CP300i has the capability to select the Video Input in three ways.

I. From the menu

1. Press **[MENU]**. Move the ShuttlePoint knob to highlight **SETUP** and press **[ENT]**.
2. Move the ShuttlePoint knob to highlight **VIDEO INPUT** and press **[ENT]** or move the ShuttlePoint knob to the right. A menu appears with the following options:
 - a. **ACTIVATE VIDEO**, the possible choices are Full Screen View, PiP (Picture in Picture) View and Auto Switch (*).

If **Full Screen View** is chosen, the GPS Chart Plotter will show a warning message with the instructions to adjust the image from the Video Input. If the user agrees to proceed, the image from the video input will be shown.

If **Picture in Picture (PiP) View** is chosen, a Video Input image can be shown on a window and placed over the selected page at full screen. By moving the ShuttlePoint knob, the PiP image is moved. When the focus is on the PiP image, press **[CLR]** to close the PiP image.

If **Auto Switch** is chosen, all the menus will be closed and the video input will be shown switching between the Video Input Full View (if connected) and the selected page. See next section for details of setting up the switching times. If the user agrees to proceed, the image from the video input and the GPS Chart Plotter page will be shown intermittently. The intermittence time is selected by Switching Timeout item.
 - b. **SWITCHING TIMEOUT**, the possible choices are 5,10,30 sec, 1, 5, 10 min. Allows selecting the timing to change from Video Input and GPS Chart Plotter display.
 - c. **RESTORE DEFAULTS**, allows restoring the factory defaults for the Input picture adjustment. When Restore default is executed, the message "OK" is shown next to the selected menu item.

NOTE (*)

If the video signal is not present on the video connector, the corresponding item in the menu will be shown with a light color (to identify that the option is not available).

II. Quick Activation by pressing **[CLR]** for 1 second

Pressing and holding **[CLR]** for 1 second from the Chart page Display or from any main page (Navigation, Highway, Celestial, GPS Status, DSC, NMEA DISPLAY); the following Soft Keys are shown: **[FULL SCREEN]**, **[PiP VIEW]**, **[AUTO SWITCH]**. If no video signal is detected on the Video Input connector, the Soft Keys will be shown in light color in order to identify that they are not active.

III. Quick Activation by Soft Keys

It is possible to assign the Video Input mode to any of the Soft Keys. Press one of the Soft Keys, the Soft Keys functions are shown. Pressing and holding for 1 second one of the Soft Keys, the Soft Keys customization list will be shown. By selecting **VIDEO** option it will be possible to assign the Soft Key to execute the Video Input function. Once the Soft Key has been assigned to Video Input, its label will show the message **[VIDEO]**. If **[VIDEO]** is pressed, the Soft Keys will be assigned this way: **[FULL SCREEN]**, **[PiP VIEW]**, **[AUTO SWITCH]**. From now on, the functioning is identical to case II.

NOTE

When the PIP video window is shown, the ShuttlePoint knob can be used to move the position of the PIP window or move the cursor around the chart page. By default the PIP window is controlled by the ShuttlePoint knob. To change so the chart cursor can be moved, press any Soft Key, then press [VIDPAGE]. To change back to control the PIP window press any Soft Key, then press [VIDPAGE] again.

NOTE

When the PIP window is shown, the cursor and the vessels position may be shown under the PIP window.

2.13 DEMO MODE (FOR DEALER USE)

In Demonstration Mode the GPS Chart Plotter automatically places a Destination point on the Chart page and simulates navigation to the point. Also, the active page changes automatically every 10 seconds. The pages are shown in the following order: Start-up screen, GPS Status page, Chart/Compass tape page, Chart/Fish Finder page, Fish Finder Full page, Radar page, Navigation page, Highway Page, Celestial page, NMEA Display page.

NOTE

This mode is used by selling dealers to promote the features of the GPS Chart Plotter when on a retail shelf.

The Demo mode can be selected from the Simulation Menu following the procedure:

1. Press **[MENU]**. Move the ShuttlePoint knob to highlight **SETUP MENU** and press **[ENT]**.
2. Move the ShuttlePoint knob to highlight **ADVANCED SETUP** and press **[ENT]** or move the ShuttlePoint knob to the right.
3. Move the ShuttlePoint knob to highlight **SIMULATION** and press **[ENT]** or move the ShuttlePoint knob to the right.
4. Move the ShuttlePoint knob to highlight **DEMO MODE** and press **[ENT]** or move the ShuttlePoint knob to the right to show the popup window.
5. Move the ShuttlePoint knob to select **On** and press **[ENT]** or move the ShuttlePoint knob to the right.
6. Demo mode is now activated.

Once the Demo mode is enabled, pressing any key it is possible to temporarily exit and returns to GPS Chart Plotter normal operation, but if you do not touch any key for 30 seconds Demo mode restarts.

To disable Demo mode follow the procedure above selecting **Off** at point 5.

3. CONTROLS AND INDICATORS

NOTE

This section defines each control of the GPS Chart Plotter. For instructions, refer to Getting Started and Advanced Settings sections of this Owner's Manual.

3.0 CONTROLS AND CONNECTIONS

The GPS Chart Plotter is controlled by using the keys located on the front panel. These labelled keys are dedicated to specific functions. As you press a key, a single audio beep confirms the key action; every time a key press is not valid, three rapid beeps sound to indicate that the key action is not valid. There is also a ShuttlePoint knob to move the cursor across the screen.

The ZOOM IN and ZOOM OUT keys

Pressing **[ZOOM IN]** shows more detail of a smaller area, by changing the chart scale and zooming in on your display. Press **[ZOOM OUT]** to change the scale and show a wider, otherwise less detailed view. Pressing and holding **[ZOOM IN]/[ZOOM OUT]** allows for quick zoom, that is the fast change of the chart scale where only the land areas are drawn. When **[ZOOM IN]/[ZOOM OUT]** is released all map details are shown.

NOTE

The GPS Chart Plotter contains a Worldwide background that allows you to zoom into 2NM. For more detail, a C-MAP BY JEPPESEN NT*/MAX C-CARD must be purchased and installed.

The ShuttlePoint knob

The ShuttlePoint knob moves the cursor about on the display screen, quickly and accurately. It also scrolls the desired option in the menu page(s). It changes the Chart Plotter from Home mode to Cursor mode on the chart screen. For a detailed explanation of Cursor VS Home mode refer to Par. 3.1.1.

The ENT key

Press **[ENT]** to select the desired option or to confirm selection.

The CLR key

Press **[CLR]** to set Home mode. Also press **[CLR]** to exit from menu or data windows or to leave a menu without making changes, to abort selected function or to step backward from a selection made in the menu.

The MENU key

Selects the Main Menu. When in the Setup Menu mode, moving the ShuttlePoint knob to the right enters a selection, moving the knob to the left clears the function.

Press and hold **[MENU]** for 3 seconds allows you to change the fields contained within the data windows while on the Chart, Navigation, Highway, GPS Status or NMEA Display Page.

Press and hold **[MENU]** for 3 seconds from Navigation, Highway, GPS Status, NMEA and Chart pages allows the data fields to be customize.

The GOTO key

This key is very useful when you desire to start navigating (goto) to a Destination point. When pressed, a popup window will be shown allowing you to select to start navigating to the position of the cursor, Mark or Route.

To stop navigation to a point, press **[GO TO]** and select Stop on the popup window.

The MARK key

Places a Mark under the ships position when in Home mode, or when the cursor is shown will place a Mark under the location of the cursor.

The ROUTE key

When pressed places a Waypoint. Succeeding presses place more Waypoints to form a Route.

The PWR key and Backlight/Contrast

Press and hold **[PWR]** to turn the GPS Chart Plotter on or off. Once on, press **[PWR]** to show the Contrast and Backlight popup window.

The MOB key

When pressed the GPS Chart Plotter automatically places a Mark on the Chart page under the boats position and all navigation is towards the position of the MOB Mark to aid in the rescue or a person that may have fallen overboard.

The INFO key

A dedicated key that allows searching the optional C-MAP BY JEPPESEN NT⁺/MAX C-CARD for Port Services, Ports, Tide Stations, Wrecks, Obstructions, Points Of Interest, Lakes Information, Lakes By Name, User Points, GPS Coordinates or Information on any point on the Chart.

3.0.0 The CP300/CP300i Soft Keys

The 6 keys in the bottom of the front panel (hereinafter named Soft Keys) have different functions associated depending on the software: their labels are shown on the screen immediately above the keys (the user can customize the function associated).

The Soft Keys

These keys allow quick selection to the many pages the GPS Chart Plotter has. These keys can be customized to your preference, however from the factory the keys are preprogrammed with the following pages. From left to right VIDEO, NAV, HIGHWAY, CELEST, CHART, LIST. Press any of the keys and you will see popup windows above the keys. To goto a specific page press the key with the desired popup window. The popup windows will automatically disappear if a key is not pressed or can be removed by pressing **[CLR]**.

3.1 GETTING STARTED

The Getting Started section will take you through the frequently used operations and assist you to customize the look of the GPS Chart Plotter.

3.1.0 Power On, Off and ShuttlePoint knob operation

1. Press and hold **[PWR]** until the display shows the start-up page. To turn off, press and hold **[PWR]** until the display turns off.
2. When the power is first turned on two pages the start-up page (see the following picture) and the Caution page are briefly shown before the GPS Status page.



Figure 3.1.0 - Example of Start-Up page on CP180

- When the GPS Chart Plotter is first turned on it will take some time for the GPS to acquire a fix of your position. Look closely at the GPS Status page and you will see satellites and relative signal strengths. After a fix is received the GPS Chart Plotter will automatically switch to the Chart page with the ships icon centered on the screen.

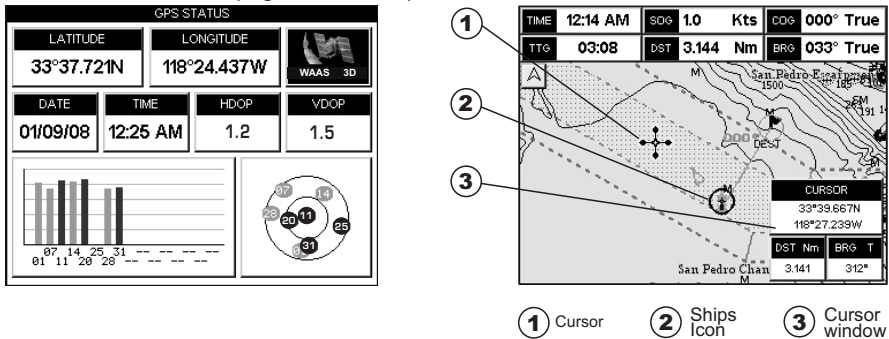

Figure 3.1.0a - GPS Status and Chart pages

- On the Chart page the ShuttlePoint knob is used to pan around the chart. Move the ShuttlePoint knob to the left and you will notice a cross hair \oplus appears, this is called the cursor.
- When you move the ShuttlePoint knob you will notice DST and BRG values in the Data window change. This shows the Distance and Bearing from the GPS Fix of your vessel to the position of the Cursor.
- If the cursor is moved to the edge of the screen the GPS Chart Plotter will automatically pan in the desired direction.

3.1.1 Cursor Vs. Home mode

Cursor mode

When the \oplus cursor icon is shown on the Chart page, this is called Cursor mode. In Cursor mode the position of the vessel will not stay in the center of the page and will move right off the edge of the screen (as your boat moves) Cursor mode allows you to pan around and look at areas on the map. In this mode you can also measure distance and bearings from your current position.

Home mode

When the $\opl�$ ship icon is shown on the Chart page (cursor is not shown) you are in Home

mode. Now as the ship moves through the water the vessels position will be kept in the center of the display.

NOTE

To change from Cursor mode to Home mode press **[CLR]**.

3.1.2 Cursor and Menu selection speed

The GPS Chart Plotter allows you to control the speed the Cursor moves when the ShuttlePoint knob is pressed. To change the speed:

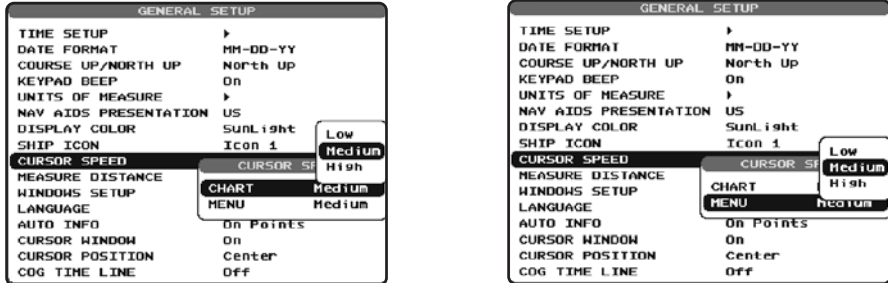

Figure 3.1.2 - Cursor Speed menu

1. Press **[MENU]**. Move the ShuttlePoint knob to highlight **SETUP MENU** and press **[ENT]**.
2. Move the ShuttlePoint knob to highlight **GENERAL SETUP** and press **[ENT]** or move the ShuttlePoint knob to the right.
3. Move the ShuttlePoint knob to highlight **CURSOR SPEED** and press **[ENT]** or move the ShuttlePoint knob to the right.
4. The menu now shows two selections, CHART and MENU which allows the Cursor Speed to be selected to High, Medium or Low on Chart page or within the menus.
5. With **CHART** or **MENU** selected, press **[ENT]** or move the ShuttlePoint knob to the right. Move the ShuttlePoint knob to the desired setting and press **[ENT]** or move the ShuttlePoint knob to the right.
6. Press **[CLR]** until the menu disappears or an easier method is to press the ShuttlePoint knob to the left a few times.
7. Move the cursor on the Chart page and see if the speed is to your liking.

3.1.3 Changing the Ship Icon

The cursor may be changed to any of the following:



Figure 3.1.3 - Ship icons

1. Press **[MENU]**. Move the ShuttlePoint knob to highlight **SETUP MENU** and press **[ENT]**.
2. Move the ShuttlePoint knob to highlight **GENERAL SETUP** and press **[ENT]** or move the ShuttlePoint knob to the right.

3. Move the ShuttlePoint knob to highlight **SHIP ICON** and press **[ENT]** or move the ShuttlePoint knob to the right to show the popup window with ship icons.
4. Move the ShuttlePoint knob to select the desired icon and press **[ENT]** or move the ShuttlePoint knob to the right to select a new icon.
5. Press **[CLR]** or move the ShuttlePoint knob to the left to exit the menu and show the Chart page.

3.1.4 Changing the backlight and contrast

With the GPS Chart Plotter is turned On, briefly press **[PWR]** to show the backlight and contrast popup window. Move the ShuttlePoint knob to the left or right to adjust the LCD backlight intensity or up or down to change the LCD contrast. Press **[ENT]** to set.

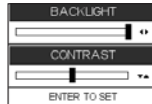

Figure 3.1.4 - Backlight and contrast adjustment

3.1.5 Selecting North Up or Course Up

The default selection is **NORTH UP**, however you may want the top of the Chart page oriented so it will always show the area ahead of the direction your vessel is travelling which is called **COURSE UP**.



Figure 3.1.5 - Course Up/North Up menu

1. Press **[MENU]**. Move the ShuttlePoint knob to highlight **SETUP MENU** and press **[ENT]**.
2. Move the ShuttlePoint knob to highlight **GENERAL SETUP** and press **[ENT]** or move the ShuttlePoint knob to the right.
3. Move the ShuttlePoint knob to highlight **COURSE UP/NORTH UP** and press **[ENT]** or move the ShuttlePoint knob to the right.
4. Another popup window will be shown with **NORTH UP** and **COURSE UP**, move the ShuttlePoint knob to the desired selection and press **[ENT]** or move the ShuttlePoint knob to the right.
5. Press **[CLR]** or move the ShuttlePoint knob to the left to exit the menu and show the Chart page.

NOTE

When the GPS Chart Plotter is in COURSE UP mode a small arrow icon (↖) will be shown on the Chart page indicating the direction of North.

3.2 AUTOMATIC TIME

The time information supplied by the GPS satellites is in Universal Time Coordinates (UTC or Greenwich England Mean Time). To change the GPS Chart Plotter to read the correct time, first you must figure out the offset and if it is daylight savings time. For example on the West coast of the United States or Pacific Standard Time the offset needed would be $-08:00$ or $-07:00$ for daylight savings time, Eastern Standard Time $-05:00$ or $-04:00$ for daylight savings time.

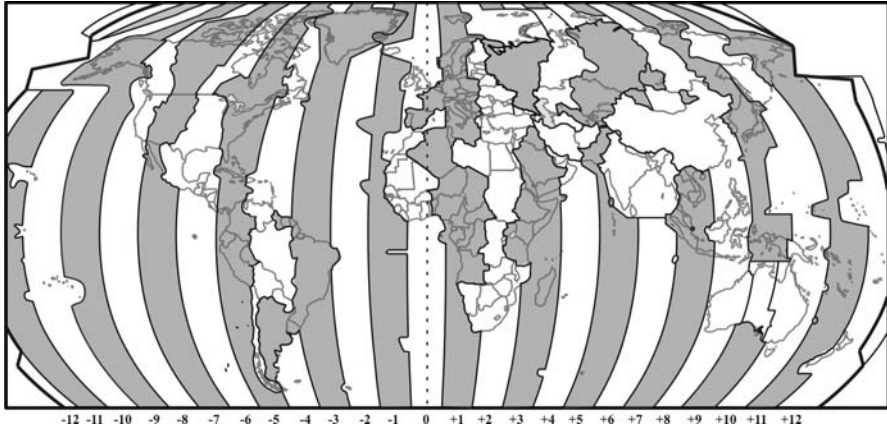

Figure 3.2 - Adjusting Time

The Time Setup menu allows the users to know the offset for the area and automatically changes the time in areas with Daylight Savings.

GENERAL SETUP			
TIME SETUP		Australia (Brisbane)	+10:00
DATE	TIME	Papua New Guinea	+10:00
COUR	TIME ZONE	Australia (Sydney)	+10:00
KEYP	DAYLIGHT SAVING	Australia (Canberra)	+10:00
UNITS	TIME FORMAT	Australia (Tasmania)	+10:00
NAV AIDS PRESENTATION		Russia (Vladivostok)	+10:00
DISPLAY COLOR		Lord Howe Island	+10:30
SHIP ICON		Kosrae, Pohnpei, Solomons	+11:00
CURSOR SPEED		Russia (Magadan)	+11:00
MEASURE DISTANCE		Norfolk Island	+11:30
WINDOWS SETUP		Fiji, Kiribati	+12:00
LANGUAGE		New Zealand	+12:00
AUTO INFO		Russia (Petropavlovsk)	+12:00
CURSOR WINDOW		Chatham Islands	+12:45
CURSOR POSITION		Tonga	+13:00
COG TIME LINE		Kiribati (Phoenix Islands)	+13:00
		Kiribati (Line Islands)	+14:00
		Other	+00:00

Figure 3.2a - Time Setup menu

NOTE

By setting the time in the steps below, the time shown on the celestial page is automatically set up.

1. Press **[MENU]**. Move the ShuttlePoint knob to highlight **SETUP MENU** and press **[ENT]**.
2. Move the ShuttlePoint knob to highlight **GENERAL SETUP** and press **[ENT]** or move the ShuttlePoint knob to the right.
3. Move the ShuttlePoint knob to highlight **TIME SETUP** and press **[ENT]** or move the ShuttlePoint knob to the right.
4. Move the ShuttlePoint knob to highlight **TIME ZONE** and press **[ENT]** or move the ShuttlePoint knob to the right.

5. Look at the table and find the time zone for your area. Move the ShuttlePoint knob up or down to select the desired zone and press **[ENT]**.
6. Next move the ShuttlePoint knob to highlight **DAYLIGHT SAVING** and press **[ENT]** or move the ShuttlePoint knob to the right.
7. Daylight Saving menu has 3 options:
 - 7.1 **OFF** Select Off when your location does not have Daylight Saving;
 - 7.2 **ON** Select On to manually turn Daylight Saving On. This is the default selection;
 - 7.3 **AUTO** When selected the Daylight time offset is automatically changed.
8. Press **[CLR]** or move the ShuttlePoint knob to the left until the Chart page is shown.

3.3 SELECTING LORAN TD OR OTHER COORDINATE SYSTEM

The GPS Fix coordinates can be changed to show Latitude/Longitude, Loran TD's or UTM. Below is the window that will appear when customizing the Coordinate System.

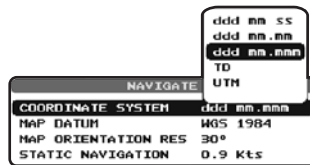

Figure 3.3 - Coordinate System menu

1. Press **[MENU]**. Move the ShuttlePoint knob to highlight **SETUP MENU** and press **[ENT]**.
2. Move the ShuttlePoint knob to highlight **ADVANCED SETUP** and press **[ENT]** or move the ShuttlePoint knob to the right.
3. Move the ShuttlePoint knob to highlight **NAVIGATE** and press **[ENT]** or move the ShuttlePoint knob to the right.
4. Move the ShuttlePoint knob to highlight **COORDINATE SYSTEM** and press **[ENT]** or move the ShuttlePoint knob to the right.
5. Move the ShuttlePoint knob to highlight the desired coordinate type and press **[ENT]** or move the ShuttlePoint knob to the right.
6. Press **[CLR]** or move the ShuttlePoint knob to the left until the Chart page is shown.

NOTE

If the TD is selected, you should set the Chain, Pair, ASF1, ASF2 and Alter. If the TD numbers are not correct the Pair letters may be backwards. Reversing the two letters usually solves this issue. Example Y/Z change to Z/Y.

3.4 CHANGING THE CHART COLOR

The GPS Chart Plotter has preprogrammed settings allowing you to customize the look of the Chart page. The default is "Sunlight" however there are other settings; Normal, Classic and Night. Night is very useful during evening hours so not to impair night vision.



Figure 3.4 - Display Color menu

1. Press **[MENU]**. Move the ShuttlePoint knob to highlight **SETUP MENU** and press **[ENT]**.
2. Move the ShuttlePoint knob to highlight **GENERAL SETUP** and press **[ENT]** or move the ShuttlePoint knob to the right.
3. Move the ShuttlePoint knob to highlight **DISPLAY COLOR** and press **[ENT]** or move the ShuttlePoint knob to the right.
4. A popup window will be shown with Normal, Classic, NOAA, Night and Sunlight. Move the ShuttlePoint knob to the desired selection and press **[ENT]** or move the ShuttlePoint knob to the right.
5. Press **[CLR]** or move the ShuttlePoint knob to the left to exit the menu and show the Chart page.

3.5 SELECTING LANGUAGE

To ease operation in different countries, the software includes translation and display of the following 15 languages:

- US English
- German
- Swedish
- Danish
- Finnish
- Italian
- Spanish
- Portuguese
- Dutch
- Russian
- French
- Norwegian
- Chinese (Traditional)
- Greek
- Chinese (Simplified)

The translations are included in Menu descriptions, Soft Key labels and on Info Functions to ease operation. See also Par. 6.0.7.

Set the language to be displayed on menus, data pages, warning/alarm messages, full/quick info, list of objects found by find/nearest function, and on charts (such as place's names, buoy's names and so on). The selection now includes the capability to display languages in non-Latin characters (UNICODE format). To select the language you want:

1. Press **[MENU]**. Move the ShuttlePoint knob to highlight **SETUP MENU** and press **[ENT]**.
2. Move the ShuttlePoint knob to highlight **GENERAL SETUP** and press **[ENT]** or move the ShuttlePoint knob to the right.
3. Move the ShuttlePoint knob to highlight User Interface **LANGUAGE** and press **[ENT]** or move the ShuttlePoint knob to the right.
4. Another popup window will be shown with the available languages, move the ShuttlePoint knob to the desired language and press **[ENT]** or move the ShuttlePoint knob to the right.
5. Press **[CLR]** or move the ShuttlePoint knob to the left to exit the menu and show the Chart page.

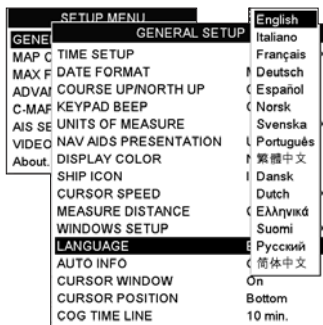

Figure 3.5 - Language Selection menu on CP300

NOTE

If the selected language is not available on cartographic data, English language is used.

WARNING

If you have accidentally selected a language and are unable to select a language that is understandable, perform the following procedure:

- Select the Chart page.
- Press **[MENU]** two times, move the ShuttlePoint knob to highlight the first (top) selection in the menu and press **[ENT]**.
- A language window will be shown, press **[ENT]**, select your language and press **[ENT]**.

3.6 SELECTING PAGES USING SOFT KEYS ON CP300/CP300i

The Soft Keys located under the LCD on the CP300 and CP300i are used to select the pages quickly without the need to go into the menu. The default pages are VIDEO, NAV, HIGHWAY, CELESTIAL, CHART and LIST.

When one of the Soft Keys is pressed popup windows above each Soft Key are shown with the key description. Press the Soft Key with the desired page description and the GPS Chart Plotter will change to that page.

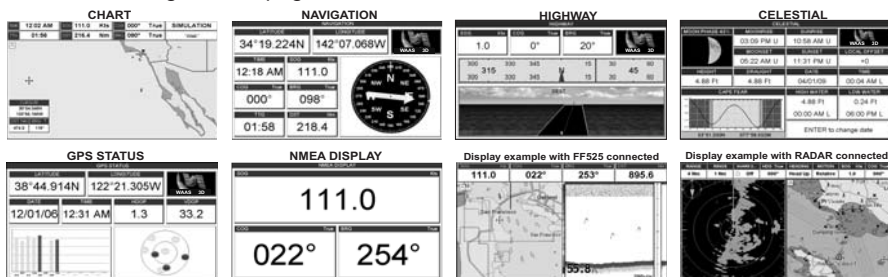

Figure 3.6 - Screen display pages on CP300/CP300i

3.7 CUSTOMIZING THE SOFT KEYS ON CP300/CP300i

The Soft Keys (CP300 and CP300i) can be individually customized from the default pages (discussed above) to the following: CHART, DUAL CHART, CHART/COMPASS, CHART/

HIGHWAY, NAVIGATION, HIGHWAY, CELESTIAL, GPS STATUS, DSC LOG, DSC DIRECTORY, NMEA DISPLAY, NMEA DATA, DEPTH TREND, WIND SPEED TREND, TEMP TREND, SOG TREND, MARKS/WAYPOINTS, USER C-CARD, AIS LIST, FIND and VIDEO INPUT.

When the Optional FF525 (or FF520) 50/200kHz BLACK BOX FISH FINDER is connected, any Soft Key can be customized to show FISH FINDER 50kHz, FISH FINDER 200kHz, FISH FINDER 50/200kHz, FISH FINDER 50kHz/CHART, FISH FINDER 200kHz/CHART screens. Also when a SI-TEX RADAR Antenna is connected (USA only), any Soft Key can be customized to show Radar pages, RADAR FULL, RADAR CHART, RADAR OVERLAY and RADAR/FISH FINDER.

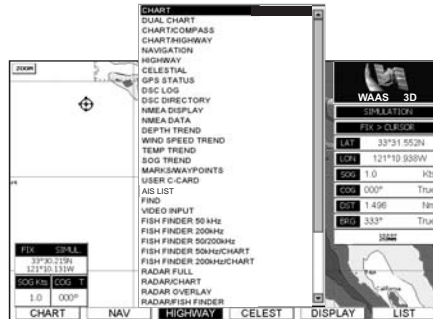

Figure 3.7 - Window options of the selected Soft Key on CP300/CP300i

1. To change, momentarily press any of the Soft Keys, then press and hold the Soft Key you want to customize.
2. A popup window will be shown with the above settings.
3. Move the ShuttlePoint knob up or down to select the desired page.
4. Press [ENT] or move the ShuttlePoint knob to the right to save the page to the selected Soft Key.

3.8 OTHER SETTINGS IN GENERAL SETUP MENU

The **GENERAL SETUP** menu has other selections that allow you to customize:

TIME SETUP	Selects a sub-menu to allow the time setup. It is possible to choose the Time Zone, select the Daylight Saving among On/Off/Auto and the Time Format, switching 12 or 24 hours time format.
DATE FORMAT	Allows choosing date format MM-DD-YY or DD-MM-YY.
COURSE UP/NORTH UP	Selections are: North Up : The Top of the page is fixed to North Course Up: The top of the page is orientated to the direction the vessel is heading.
KEYPAD BEEP	Allows the beep produced when a key is pressed to be turned on or off.
UNITS OF MEASURE	Units of Measure can be selected for Distance, Speed, Depth, Altitude and Temperature.
NAV AIDS PRESENTATION	Allows the Nav Aids presentation to be drawn using NOAA symbology when US is selected or International symbols will be used when International is selected. When selected these functions affect how the icons for Lights, Signals, Buoys and beacons are displayed.
DISPLAY COLOR	Changes the background colors of the chart page to enhance the visibility of the screen depending on the surrounding light conditions. Normal is recommended when the GPS Chart Plotter is not exposed to the direct sunlight. When this mode is set the maps are displayed in order to use colors as similar as possible to ones used in the original paper

charts. **Classic** uses vivid chart colors presentation. **NOAA** allows setting NOAA paper chart colors presentation. **Night** is recommended when the environment is dark in order to reduce the glare of the display. The GPS Chart Plotter displays maps and screen in darker colors. **Sunlight** (default) is designed to enhance the visibility of the screen when the GPS Chart Plotter is exposed to sunlight. The maps are much brighter than in the other modes and the depth areas are filled with the white color so different depth areas are not easily distinguishable.

SHIP ICON	Allows selection of one of 5 choices of ship icons that represent your vessels position shown on the chart page.
CURSOR SPEED	Selects the preferred speed among Low, Medium and High for the cursor in the Chart page and within the menu.
MEASURE DISTANCE	When this function is turned on allows a distance to be measured between two points using the ShuttlePoint knob and [ENT] .
WINDOWS SETUP	This menu selection allows the data windows to be customized on the Chart and Navigation pages.
LANGUAGE	Allows changing the language for menus and data screens.
AUTO INFO	By default when the cursor is moved over a buoy, Mark or other item a popup window will show information of the item. This menu item allows the window to be turned on or off.
CURSOR WINDOW	By default when the cursor is moved a window is shown with the lat/lon Distance and bearing from the vessels location to the cursor. This selection allows the window to be turned off.
CURSOR POSITION	The position of the cursor (vessels location) can be customized so it centered in the middle or centered on the bottom of the chart page.
COG TIME LINE	Is a line projected from the vessel icon which indicates the distance your vessel will travel at the current speed. Selections are 2, 10, 30 minutes, 1, 2 hours and infinite.

3.9 INFORMATION PAGE

From Main Menu page it is possible to select an Information page containing Software, Chart and Optional devices information.

① Software System Information

② Cartography Information

③ Storage Capacity

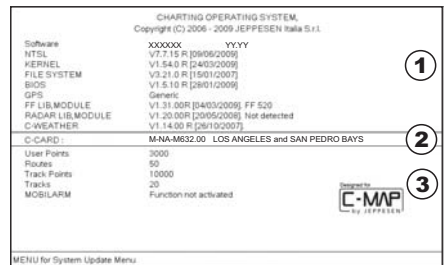

Figure 3.9 - Example of About page on CP300

1. Press **[MENU]**. Move the ShuttlePoint knob to highlight **SETUP MENU** and press **[ENT]**.
2. Move the ShuttlePoint knob to highlight **About...** and press **[ENT]** or move the ShuttlePoint knob to the right.
3. The Information page appears on the screen (see the previous Figure).
4. Press **[CLR]** or move the ShuttlePoint knob to the left to exit and show the Chart page.

4. FIND SERVICES

4.0 USING FIND SERVICES & MORE FUNCTIONS

The CP180/180i and CP300/300i have a dedicated **[INFO]** key that allows searching the optional C-MAP By JEPPESEN NT*/MAX C-CARD for Port Services, Ports, Tide Stations, Wrecks, Obstructions, Points Of Interest, Lakes, User Points, GPS Coordinates or Information on any point on the Chart.

4.0.0 Port Services

This feature is used to locate Port Services nearest the position of your vessel.

1. Press **[INFO]**.
2. Move the ShuttlePoint knob to highlight **PORT SERVICES** and press **[ENT]** or move the ShuttlePoint knob to the right.
3. A popup window will be shown with a list of different Port Services. In the table below is shown the list of the available Port Services:

HEALTH EMERGENCY	HARBOUR MASTER	COAST GUARD	ENGINE REPAIRS	FUEL STATION	WATER	PROVISIONS	CAR PARKING	SEWERAGE PUMP-OU...	PUBLIC TELEGRAPH	PUBLIC RADIO	TRANSPD. SERVICES
ELECTRICITY	POLICE	CUSTOMS... POLICE	BOAT YARD	ACCESSOR... ELECTRON...	ELECTRICA... REPAIRS	COMMERCIAL FISHING SE...	OTHER MARIN...	TOWING SERVICES	PORT PARTNER	BAIT/TACKLE SHOP	OFFICE SERVICE
SAILMAKER	FISHING/DI... GEAR.SCU...	PHARMACY	SLIPWAY	BOAT HOIST	CRANE	NEWSSTAND	CHARTER	LAND BASED VESSEL ST...	AIRPORT	HULL REPAIRS	SPORT ACTIVITY
CHANDLER	BOTTLE GAS	PARKING FOR BO...	YACHT CLUB	HOTEL/INN	RESTAUR...	BOAT RENTAL	FLOODLIT BERTHS	INTERNET POINT	FIRST AID	BOUTIQUE	BAR
BANK/EXC... OFFICE	SHOWERS	LAUNDRE...	PUBLIC TOILETS	PUBLIC TELEPHONE	REFUSE BIN	WATCHING SERVICE	DIVERS	MOORING SERVICE	PROVISION DELIVERY		

Figure 4.0.0 - Port Services Table

4. Move the ShuttlePoint knob to highlight the desired type of service and press **[ENT]**.
5. Another popup window will appear displaying the distance and position of the services closest to your location.
6. Using the ShuttlePoint knob, highlight the desired Service and press **[ENT]**. This will show information on the service.
7. Press **[CLR]** to show the actual position of the service on the Chart page.
8. Press **[CLR]** again at any time to return your cursor to your vessels position.

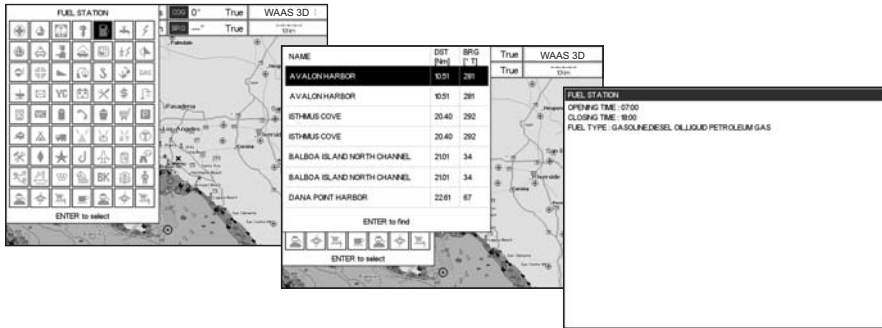



Figure 4.0.0a - Find Port Services

4.0.1 Port

This feature is used to locate Port nearest the position of your vessel.

A Port is represented with a  on the Chart page.

1. Press **[INFO]**.
2. Move the ShuttlePoint knob to highlight **PORT** and press **[ENT]** or move the ShuttlePoint knob to the right.
3. A popup window will be shown with a list of nearest Ports.
4. Move the ShuttlePoint knob to highlight the desired Port and press **[ENT]**.
5. Another window will appear displaying the details of the selected Port.
6. Press **[CLR]** to show the actual position of the Port on the Chart page.
7. Press **[CLR]** again at any time to return your cursor to your vessels position.



Figure 4.0.1 - Find a Port

4.0.2 Tide Stations

This feature is used to locate Tide Stations nearest the position of your vessel. Once a Tide Station is selected the Tide Graph can be used to determine Tide height and draught of the Tide based on a user specified time.

A Tide Station is represented with a  on the Chart page.

1. Press **[INFO]**.
2. Move the ShuttlePoint knob to highlight **TIDE STATIONS** and press **[ENT]** or move the ShuttlePoint knob to the right.
3. A popup window will be shown with a list of nearest Tide Stations.
4. Move the ShuttlePoint knob to highlight the desired Tide Station and press **[ENT]**.

- Another window will be shown detailing the selected Tide Station information.
- Press **[CLR]** to show the actual position of the Tide Station on the Chart page.
- Press **[CLR]** again at any time to return your cursor to your vessels position.

NAME	DIST (Nmi)	SPD (kts)	True	WAAS 3D
AVALON	8.00	306		
AVALON SANTA CATALINA ISLAND	8.30	278		
NEWPORT BA Y ENTRANCE CORON	20.02	33		
BALBOA PEP. NEWPORT BEACH	20.02	33		
CATALINA HARBOR	20.25	289		
NEWPORT BAY	20.58	35		
LOS PATOS (HIGHWAY BRIDGE)	23.45	8		
CAMPBELL BEACH	24.36	342		
LOS ANGELES HARBOUR	24.85	343		

ENTER to find

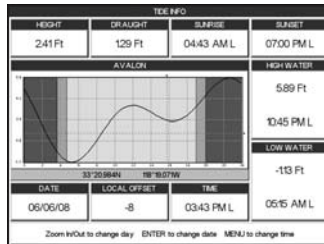



Figure 4.0.2 - Tide Stations

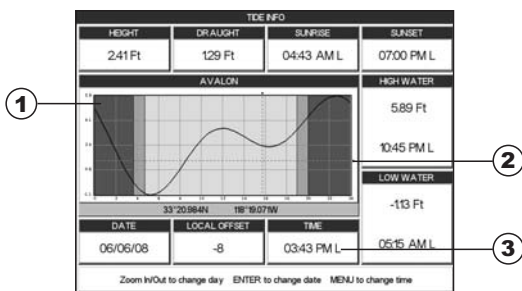

Figure 4.0.2a - Tide Graph page

Refer to the image above. The time (3) displayed corresponds to the location of the cross-hair cursor (2) in the Tide Graph (1). Moving the ShuttlePoint knob to the left or right changes the time, moving the ShuttlePoint knob up or down selects the Tide height and Tide draught on the Tide Graph.

NOTE

The Local Offset matches the Time Offset entered in the Time Setup menu (see Par. 3.2)

4.0.3 Wrecks

This feature is used to locate Wrecks nearest the position of your vessel. A Wreck is represented with an icon on the chart, see the following table:



ICON	DESCRIPTION
++	non-dangerous wreck
	dangerous wreck
# [FOUL]	distributed remains of wreck
 <i>Masts</i>	wreck showing mast/masts
	wreck showing any portion of hull or superstructure

Figure 4.0.3 - Wreck icons Table

1. Press **[INFO]**.
2. Move the ShuttlePoint knob to highlight **WRECKS** and press **[ENT]** or move the ShuttlePoint knob to the right.
3. A popup window will be shown with a list of nearest Wrecks.
4. Move the ShuttlePoint knob to highlight the desired Wreck and press **[ENT]**.
5. Another window will be shown detailing the Wreck information.
6. Press **[CLR]** to show the actual position of the Wreck on the Chart page.
7. Press **[CLR]** again at any time to return your cursor to your vessels position.

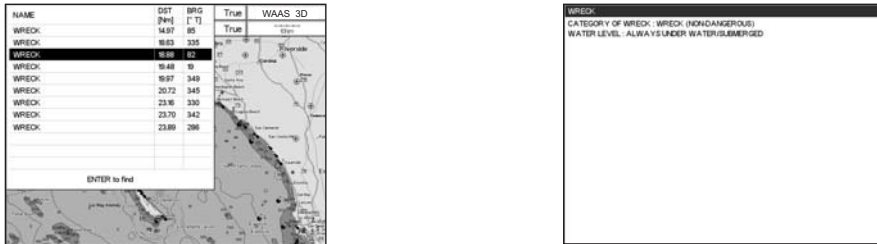

Figure 4.0.3a - Find Wrecks

4.0.4 Obstructions

This feature is used to locate Obstructions nearest the position of your vessel. An Obstruction is represented with an icon on the chart, see the following table:









ICON	DESCRIPTION
 <i>Obstn</i>	snag/stump
 <i>Mast (I₂)</i> <i>Wk</i>	wellhead
# 	diffuser
# 	crib
	fish haven
	foul area
#  <i>F o u l</i>	foul ground
	ice boom
 <i>Obstn</i>	ground tackle

Figure 4.0.4 - Obstruction icons Table

1. Press **[INFO]**.
2. Move the ShuttlePoint knob to highlight **OBSTRUCTIONS** and press **[ENT]** or move the ShuttlePoint knob to the right.
3. A popup window will be shown with a list of nearest Obstructions.
4. Move the ShuttlePoint knob to highlight the desired Obstruction and press **[ENT]**.
5. Another window will be shown detailing the Obstruction information.
6. Press **[CLR]** to show the actual position of the Obstruction on the Chart page.
7. Press **[CLR]** again at any time to return your cursor to your vessels position.

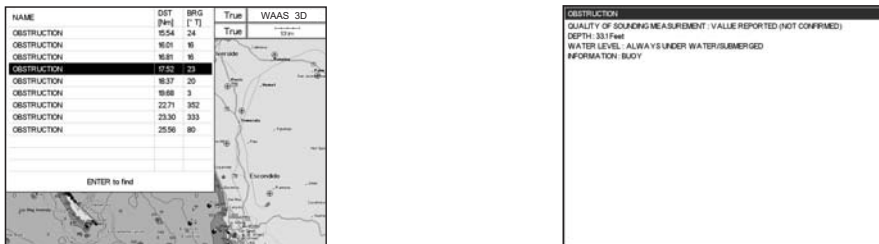



Figure 4.0.4a - Find Obstructions

4.0.5 Lakes Information

This feature is used to find information on Lakes nearest the position of your vessel.

A Lake Info is represented with a  on the Chart page.

NOTE

An optional MAX Lake CARD must be inserted into the GPS Chart Plotter to take advantage Lakes Information. The available MAX Lake CARDS are: NA-M017 USA: North; NA-M018 USA: East; NA-M019 USA: South; NA-M020 USA: West; NA-M029: Alaska; NA-M048: Canada.

1. Press **[INFO]**.
2. Move the ShuttlePoint knob to highlight **LAKES INFORMATION** and press **[ENT]** or move the ShuttlePoint knob to the right.
3. A popup window will be shown with a list of Outdoor Recreational Area objects.
4. Move the ShuttlePoint knob to highlight the desired object and press **[ENT]**.
5. Another popup window will appear displaying the distance and position of the Lakes closest to your location.
6. Using the ShuttlePoint knob, highlight the desired Lake and press **[ENT]**. This will show information on the Lake.
7. Press **[CLR]** to show the actual position of the Lake on the Chart page.
8. Press **[CLR]** twice to return your cursor to your vessels position.

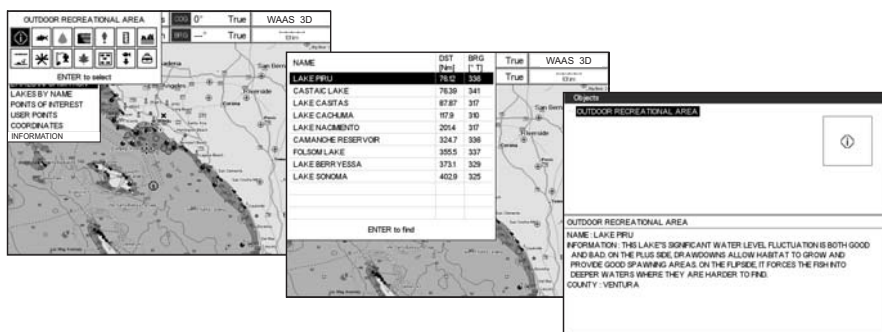

Figure 4.0.5 - Find Lakes Information

4.0.5.0 Quick Info On Lakes

Upon viewing the chart of a lake, you can click on the Lake Info icon to query the available information immediately displayed with many details. For example, see the following picture:

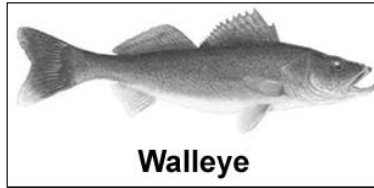

Figure 4.0.5.1a - Example of picture associated to the Fishing object

4.0.6 Lakes By Name

This feature is used to locate Lakes By Name nearest the position of your vessel.

1. Press **[INFO]**.
2. Move the ShuttlePoint knob to highlight **LAKES BY NAME** and press **[ENT]** or move the ShuttlePoint knob to the right.
3. A popup window will be shown with a list of nearest Lakes.

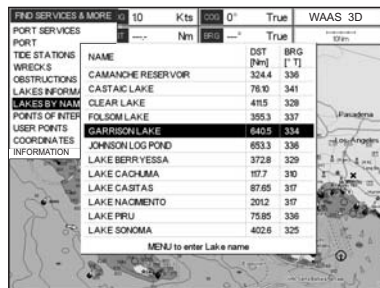

Figure 4.0.6 - Find Lakes By Name

4. Move the ShuttlePoint knob to highlight the desired Lake. Otherwise press **[MENU]** to enter the desired Lake name. A window will be shown: move the ShuttlePoint knob to highlight the edit of Lake name and press **[ENT]** to accept: another popup window will appear displaying the distance and position of the Lake.
5. Press **[ENT]** to show the actual position of the Lake on the Chart page.
6. Press **[CLR]** twice to return your cursor to your vessels position.

4.0.7 Points Of Interest

This feature is used to locate Points Of Interest nearest the position of your vessel.

1. Press **[INFO]**.
2. Move the ShuttlePoint knob to highlight **POINTS OF INTEREST** and press **[ENT]** or move the ShuttlePoint knob to the right.
3. A (Category) popup window will be shown with a list of Category types (i.e. attractions, emergency, entertainment).
4. Move the ShuttlePoint knob to highlight the desired Category and press **[ENT]**.
5. A (Type) popup window will be shown with a list of types.
6. Move the ShuttlePoint knob to highlight the desired Type and press **[ENT]**.
7. A popup window will be shown with a list of nearest Points Of Interest that fall into the Category and Type you have selected.
8. Move the ShuttlePoint knob up/down to highlight the desired Point Of Interest and press **[ENT]**.

9. Another window will be shown with detailing the Point Of Interest information.
10. Press **[CLR]** to show the actual position of the Point Of Interest on the Chart page.
11. Press **[CLR]** again at any time to return your cursor to your vessels position.



Figure 4.0.7 - Find Points Of Interest

4.0.8 User Points

This feature is used to search for User Points (Marks and Waypoints you have created and stored) by name quickly and efficiently.

1. Press **[INFO]**.
2. Move the ShuttlePoint knob to highlight **USER POINTS** and press **[ENT]** or move the ShuttlePoint knob to the right.
3. The (Select Name) popup window will appear. This window will allow you to enter in the name of the User Point you wish to locate.
4. Move the ShuttlePoint knob up/down to change each number or letter and left/right to move to the next or previous position in the name of the Mark.
5. Once the name of the desired Mark reads in the (Select Name) window, press **[ENT]** to show the location the Mark on the Chart page.
6. Press **[CLR]** at any time to return your cursor to your vessels position.

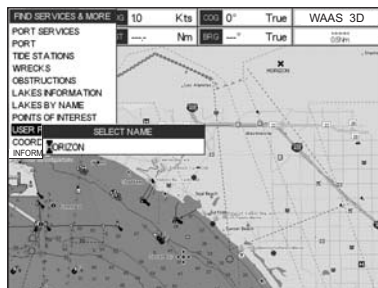

Figure 4.0.8 - Find User Points (Marks and Waypoints)

4.0.9 Coordinates

This feature allows you to enter Coordinates (Latitude/Longitude) and view the entered position on the Chart page.

1. Press **[INFO]**.

2. Move the ShuttlePoint knob to highlight **COORDINATES** and press **[ENT]** or move the ShuttlePoint knob to the right.
3. A (Coordinate) popup window will be shown to allow you to enter in a specified Latitude and Longitude.
4. Move the ShuttlePoint knob up/down to change each number or letter and left/right to move to the next or previous position in the Coordinates.
5. Once the Coordinates are entered, press **[ENT]** to show the location the Mark on the chart page.
6. Press **[CLR]** at any time to return your cursor to your vessels position.

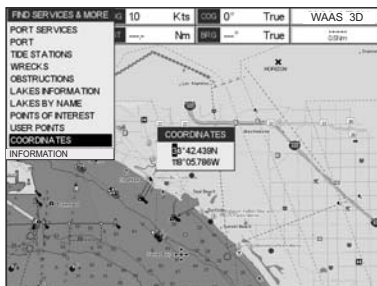

Figure 4.0.9 - Find GPS Coordinates

4.0.10 Information

This feature allows you to obtain information on any position on the chart page.

1. Press **[INFO]**.
2. Move the ShuttlePoint knob to highlight **INFORMATION** and press **[ENT]** or move the ShuttlePoint knob to the right.
3. A page will be shown with objects information. The upper side of the page contains the Info Tree and the lower side contains the expanded information. While moving the ShuttlePoint knob through the Info Tree, all the relevant information of the selected object is shown on the lower part of the page.
4. Press **[CLR]** again at any time to return your cursor to your vessels position.

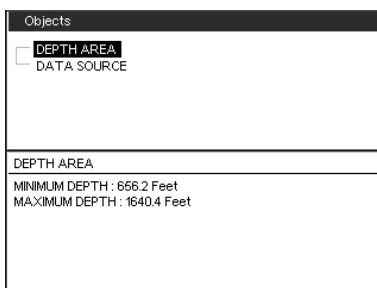

Figure 4.0.10 - Find Information

5. MAX CARTOGRAPHY OVERVIEW

5.0 INSERTING THE C-CARD

Hold the C-CARD by the long inclined side so that you can see the C-MAP BY JEPPESEN label.

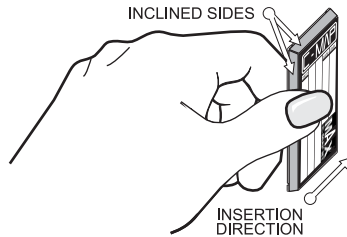

Figure 5.0 - Inserting C-CARD

Open the door, gently push the C-CARD into the slot: push the C-CARD in as far as it will go, then close the door.

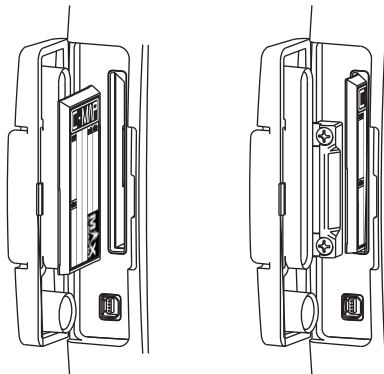

Figure 5.0a - Inserting C-CARD (Details)

C-MAP BY JEPPESEN MAX is a major evolution of the product technology. Key points are:

Data Features

- **ISO Certification** (*electronic chart production process with quality certification*)
- **Extra Large Coverage** (*all the C-Map electronic chart detail and a huge coverage without having to change cartridge*)
- **Official data source** (*data based on use of official data sources Hydrographic Offices Release*)
- **Detailed World Background** (*worldwide background chart with details*)
- **Depths & Land Elevations** (*color shading of sea depth and land altitude for improved chart appearance*)
- **Bathymetric & Spot Soundings** (*Data Base with depth and bathy information for an extraordinary view of the seabed depth*)

- **Detailed Port Plan to information** (complete port and marina charts with detail)
- **Search & Find** (quickly locates chart contents and objects)
- **Tides Preview** (allows viewing of current, future and past tide cycles of specific NOAA Tide Stations)
- **Dynamic Currents** (current arrows showing speed and direction of current, future and past currents)
- **Dynamic Nav-Aids** (selection to enable the Nav-Aids to blink to their specifications and appear on the chart in color)
- **Port Info** (searchable data base of service in ports)
- **Enhanced Port Info & Roads** (searchable data base of detailed information that include facilities and services in ports and surrounding areas)
- **Object Info** (moving cursor over object to show restricted area details and related information)
- **Quick Info** (moving cursor over wrecks, shoals, Nav-Aids to show restricted area details and related information and object to show details)
- **Photos & Diagrams** (high definition pictures of ports, piers, bridge diagrams and nav-aids)
- **Multilanguage Support** (allows the plotter to show language of your choice in using proper character set for Asian and other countries)
- **True-Type Font** (improves text on chart for optimal reading)

Presentation Features

- **Clear View** (advanced legibility techniques providing more chart data on the screen)
- **Clear Info** (sophisticated "Human Dictionary" to translate Nav-Aid abbreviations found on paper charts)
- **Flexi-Zoom** (increased Under and Over Zoom between chart levels, resulting in optimal scale display for any situation)
- **Perspective View** ("Real World" perspective view of the chart, updated real-time during navigation)
- **Enhanced Mixing Levels** (seamless data presentation)
- **Off-line redraw** (cartography level transition without image construction)

Cartographic Data related Features

- **Guardian Alarm** (the Guardian Alarm is a user defined area in front of your vessel to alert you while navigating of possible obstacles on the chart)
- **Safety Status Bar** (a status bar with six boxes to show the status of certain functions. Any warning or alarm condition is identified by the red color to indicate possible risk)
- **Safety Route Check** (sophisticated function that checks for dangerous objects along your navigation route)

MAX and NT/NT+ C-CARD coexistence

- When NT+ data and MAX data cover different areas, the GPS Chart Plotter receives data from both charts (depending on the current position).
- When NT+ data and MAX data cover the same area, the GPS Chart Plotter receives data only from MAX chart.

6. MAP FUNCTIONS

6.0 MAX FUNCTIONS MENU

1. Press **[MENU]**. Move the ShuttlePoint knob to highlight **SETUP MENU** and press **[ENT]**.
2. Move the ShuttlePoint knob to highlight **MAX FUNCTIONS** and press **[ENT]** or move the ShuttlePoint knob to the right. The MAX Functions menu appears on the screen:

MAX FUNCTIONS	
ZOOM TYPE	Standard
ICONS SIZE	Standard
PLACE NAMES SIZE	Standard
PERSPECTIVE VIEW	Off
DYNAMIC NAV-AIDS	On
SAFETY STATUS BAR	Off
SATELLITE IMAGERY	On
CURRENTS PREDICTION	
CHART LANGUAGE	*

Figure 6.0 - Max Functions Menu

The available Max Functions menu is described in the following.

6.0.0 Zoom Type

Zoom Type refers to the chart scale selection. It has two options: Standard (default) or Flexi-Zoom. When Zoom Type is set to Flexi-Zoom, a short **[ZOOM IN]/[ZOOM OUT]** push causes a change of chart level, while a long **[ZOOM IN]/[ZOOM OUT]** push (press and hold) causes an expansion or compression of the chart image, without a chart level change.

CHART: US,NOS,GRAPH,11428D
SCALE: 1:40000

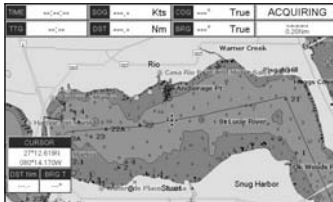

CHART: US,NOS,GRAPH,11428D
SCALE: 1:40000

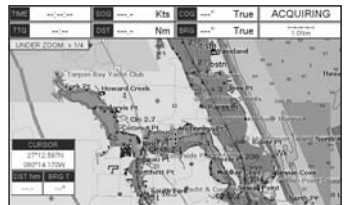

CHART: US,NOS,GRAPH,11474
SCALE: 1:80000

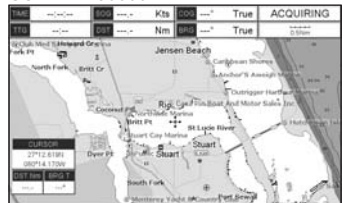

Figure 6.0.0 - Zoom Type

Note that in the top of the previous picture the chart scale remains the same but it is graphically compressed.

By pressing **[ZOOM IN]/[ZOOM OUT]** a popup window is displayed on a corner of the chart screen. The window shows the current zoom factor: Normal is the original chart level (1:1 scale), Over-Zoom x2, x4, x16, x32, Under-Zoom x1/2, x1/4.

To activate this function follow the procedure:

1. Press **[MENU]**. Move the ShuttlePoint knob to highlight **SETUP MENU** and press **[ENT]**.
2. Move the ShuttlePoint knob to highlight **MAX FUNCTIONS** and press **[ENT]** or move the ShuttlePoint knob to the right.
3. Move the ShuttlePoint knob to highlight **ZOOM TYPE** and press **[ENT]** or move the ShuttlePoint knob to the right.
4. The menu now shows two selections, **STANDARD** or **FLEXI-ZOOM**.
5. Move the ShuttlePoint knob to select the selection and press **[ENT]**.
6. Press **[CLR]** until the menu disappears or an easier method is to move the ShuttlePoint knob to the left a few times.

6.0.1 Icons Size

On MAX charts it is possible to set the size of all icons drawn on the charts, selecting between Standard and Large size.

ICONS SIZE standard



ICONS SIZE large



Figure 6.0.1 - Icons Size

To activate this function follow the procedure:

1. Press **[MENU]**. Move the ShuttlePoint knob to highlight **SETUP MENU** and press **[ENT]**.
2. Move the ShuttlePoint knob to highlight **MAX FUNCTIONS** and press **[ENT]** or move the ShuttlePoint knob to the right.
3. Move the ShuttlePoint knob to highlight **ICONS SIZE** and press **[ENT]** or move the ShuttlePoint knob to the right.
4. The menu now shows two selections, **STANDARD** or **LARGE**.
5. Move the ShuttlePoint knob to select the selection and press **[ENT]**.
6. Press **[CLR]** until the menu disappears or an easier method is to move the ShuttlePoint knob to the left a few times.

6.0.2 Place Names Size

On MAX charts it is possible to set the size of all names drawn on the charts, selecting between Standard, Medium and Large size.

PLACE NAMES SIZE standard

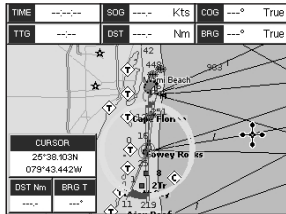

PLACE NAMES SIZE medium

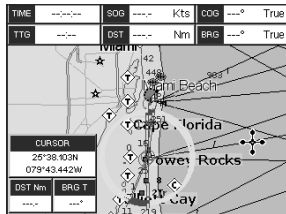

PLACE NAMES SIZE large

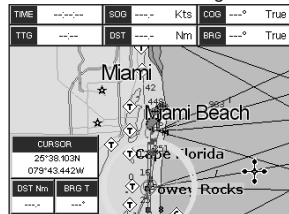

Figure 6.0.2 - Place Names Size

To activate this function follow the procedure:

1. Press **[MENU]**. Move the ShuttlePoint knob to highlight **SETUP MENU** and press **[ENT]**.
2. Move the ShuttlePoint knob to highlight **MAX FUNCTIONS** and press **[ENT]** or move the ShuttlePoint knob to the right.
3. Move the ShuttlePoint knob to highlight **PLACE NAMES SIZE** and press **[ENT]** or move the ShuttlePoint knob to the right.
4. The menu now shows two selections, **STANDARD**, **MEDIUM** or **LARGE**.
5. Move the ShuttlePoint knob to select the selection and press **[ENT]**.
6. Press **[CLR]** until the menu disappears or an easier method is to move the ShuttlePoint knob to the left a few times.

6.0.3 Perspective View

The Chart page may show in a perspective (fly over) or normal mode during navigation. Perspective view of the chart is a type of “bird’s eye” view of a chart, and give you a more realistic perspective of the chart. As the upper side of the map is more compressed than the lower side, a wider map area is visible, so it allows showing more chart information immediately ahead and around the cursor.

Perspective View ON

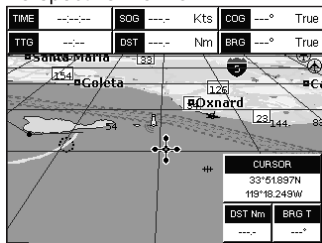

Perspective View OFF

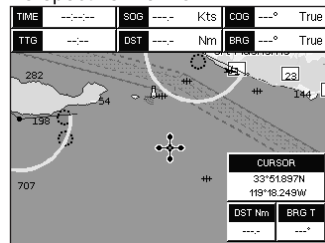

Figure 6.0.3 - Perspective View

To activate this function follow the procedure:

1. Press **[MENU]**. Move the ShuttlePoint knob to highlight **SETUP MENU** and press **[ENT]**.
2. Move the ShuttlePoint knob to highlight **MAX FUNCTIONS** and press **[ENT]** or move the ShuttlePoint knob to the right.
3. Move the ShuttlePoint knob to highlight **PERSPECTIVE VIEW** and press **[ENT]** or move the ShuttlePoint knob to the right.
4. The menu now shows two selections, **ON** or **OFF**.
5. Move the ShuttlePoint knob to select the selection and press **[ENT]**.
6. Press **[CLR]** until the menu disappears or an easier method is to move the ShuttlePoint knob to the left until the chart page is shown.

6.0.4 Dynamic Nav-Aids

This function allows the blinking of the Nav-Aids to be turned On or Off. The blink period and color of each Nav-aid is read from the Nav-Aid attributes stored on the optional C-MAP BY JEPPESEN C-Card. When the ship is inside the Nav-Aid nominal range, the light of the Nav-Aid will start blinking. When Dynamic Nav-Aids option is set to On, when the flashing light is Off, or when fix position is out of the sector, the light color is displayed by using a faint light color.

To activate this function follow the procedure below:

1. Press **[MENU]**. Move the ShuttlePoint knob to highlight **SETUP MENU** and press **[ENT]**.
2. Move the ShuttlePoint knob to highlight **MAX FUNCTIONS** and press **[ENT]** or move the ShuttlePoint knob to the right.
3. Move the ShuttlePoint knob to highlight **DYNAMIC NAV-AIDS** and press **[ENT]** or move the ShuttlePoint knob to the right.
4. The menu now shows two selections, **ON** or **OFF**.
5. Move the ShuttlePoint knob to select the selection and press **[ENT]**.
6. Press **[CLR]** until the menu disappears or an easier method is to move the ShuttlePoint knob to the left until the chart page is shown.

6.0.5 Safety Status Bar (DSI - Data Safety Indicator)

When the Safety Status Bar is enabled, a status bar with six boxes show the status of certain functions. Any warning or alarm condition is identified by the red color to indicate possible risk.

To activate this function follow the procedure:

1. Press **[MENU]**. Move the ShuttlePoint knob to highlight **SETUP MENU** and press **[ENT]**.
2. Move the ShuttlePoint knob to highlight **MAX FUNCTIONS** and press **[ENT]** or move the ShuttlePoint knob to the right.
3. Move the ShuttlePoint knob to highlight **SAFETY STATUS BAR** and press **[ENT]** or move the ShuttlePoint knob to the right.
4. The menu now shows the following selections: **ON** (The Safety Status Bar is shown), **OFF** (The Safety Status Bar is not shown), **ICON** (The Safety Status Bar is not shown, but a Warning alarm Icon is shown on the corner of the map screen as soon as any item controlled by the DSI function returns an alarm condition. The Warning Icon remains displayed until the alarm condition persists. Placing the cursor over this Icon, a quick help message is shown next to the Icon, allowing the Safety Status Bar to be shown. In this case - when the Safety Status Bar is opened via Warning alarm Icon - it is allowed to obtain information about each "active" Safety Status box (the red ones): it is possible to select them by ShuttlePoint knob movement left/right, and a list of active alarms is shown underneath the selected box. By pressing **[CLR]**, the Safety Status Bar is removed from the screen.
5. Move the ShuttlePoint knob to select the selection and press **[ENT]**.
6. Press **[CLR]** until the menu disappears or an easier method is to press the ShuttlePoint knob to the left a few times.



Safety Status Bar

- ① **Normal:** when the chart is displayed at normal scale.
U. Zoom: red when the chart is under-zoomed out more than twice normal scale, gray otherwise.
O. Zoom: red when the chart is over-zoomed in more than twice normal scale, gray otherwise.
Chart Lock: red when the chart is zoomed in more than twice normal scale, gray otherwise.

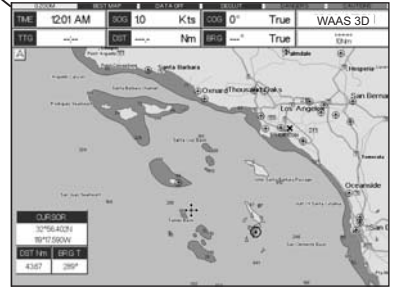

- ② Red when a more detailed chart is available under the cursor position.
- ③ Red when at least one of the following objects or layers is turned off (by the user) Depths/soundings; Wrecks/obstructions; Tracks/routes; Attention Areas; Nav-Aids.
- ④ Displays red when clearing overlapping objects.
- ⑤ Red when "Guardian Technology" detects one of the following objects: Land, Intertidal, Depth Area, Rocks, Obstructions, Shoreline Constructions, Fishing Facility, Wrecks, Dragged area, Diffusion area, Mooring facilities, Pingos and Production installations.
- ⑥ Red when "Guardian Technology" detects cautionary or restricted area.

Figure 6.0.5 - Safety Status Bar

6.0.6 Satellite Imagery

This function allows to overlay the Satellite image for background map. When it is set On, the Palette is set to Normal to display the proper colors.

NOTE

The satellite image is only shown on 100NM, 50NM and 20NM scales.

To activate this function follow the procedure below:

1. Press **[MENU]**. Move the ShuttlePoint knob to highlight **SETUP MENU** and press **[ENT]**.
2. Move the ShuttlePoint knob to highlight **MAX FUNCTIONS** and press **[ENT]** or move the ShuttlePoint knob to the right.
3. Move the ShuttlePoint knob to highlight **SATELLITE IMAGERY** and press **[ENT]** or move the ShuttlePoint knob to the right.
4. The menu now shows two selections, **ON** or **OFF**.
5. Move the ShuttlePoint knob to select the selection and press **[ENT]**.
6. Press **[CLR]** until the menu disappears or an easier method is to move the ShuttlePoint knob to the left until the Chart page is shown.

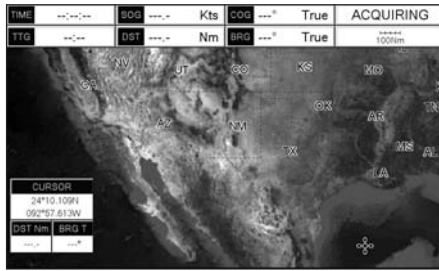

Figure 6.0.6 - Example of Satellite Imagery on CP300i

6.0.7 Currents Prediction

The worldwide database with tidal stream information is available with MAX C-CARDS. When data/time is available, Tidal stream arrows are shown on the charts, indicating the direction and strength of the Tide:

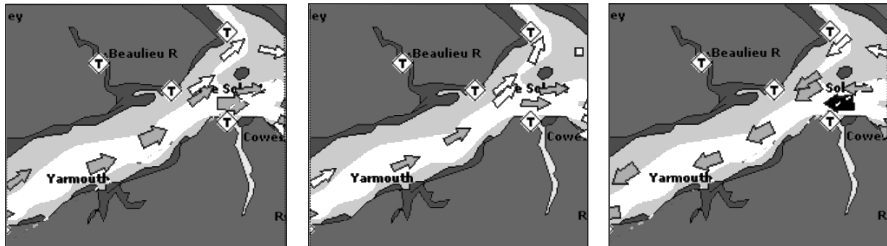

Figure 6.0.7 - Tidal stream arrows

If no data/time is available from the GPS or the GPS Chart Plotter is not in Simulation mode, the icon on the map is generic one. The color of the arrow denotes the strength of the current as follows:

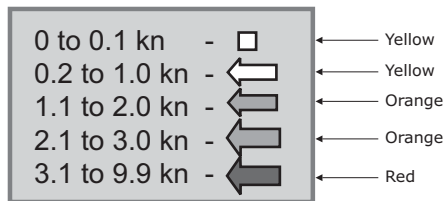

Figure 6.0.7a - Tidal stream arrows table

When the GPS Chart Plotter receives a valid position fix, the Tide icons are shown on the charts on the basis of the current date and time: the screen displays and changes arrows as date/time changes.

It is possible to see the variation of the Tidal arrows on the selected area at any given time. To activate this function follow the procedure:

1. Press **[MENU]**. Move the ShuttlePoint knob to highlight **SETUP MENU** and press **[ENT]**.
2. Move the ShuttlePoint knob to highlight **MAX FUNCTIONS** and press **[ENT]** or move the ShuttlePoint knob to the right.

3. Move the ShuttlePoint knob to highlight **CURRENTS PREDICTION** and press [ENT] or move the ShuttlePoint knob to the right.
4. A window is shown on the low-left side of the chart. On the CP300/CP300i press [SET TIME] to set the date and time manually, and [INCR. TIME]/[DECR. TIME] to decrease/increase time; press [EXIT] to exit. On the CP180/CP180i press [ENT] to set the date and time manually, and [GOTO]/[MENU] to decrease/increase time; press [CLR] to exit.

6.0.8 Chart Language

The CP180/CP180i and CP300/CP300i may be customized to show the local language of the chart. To select the Chart Language you want:

1. Press [MENU]. Move the ShuttlePoint knob to highlight **SETUP MENU** and press [ENT].
2. Move the ShuttlePoint knob to highlight **MAX FUNCTIONS** and press [ENT] or move the ShuttlePoint knob to the right.
3. Move the ShuttlePoint knob to highlight **CHART LANGUAGE** and press [ENT] or move the ShuttlePoint knob to the right. A new popup window will appear on the screen. The available functions are described in the table below.

Language	: Allows setting the language to display chart information. The language is chosen among the list of languages available on the cartographic data (data cartridge or embedded charts).
Mode	: Defines how objects are translated. Selections are: Off : Enables the language chosen in the Language menu above. If the selected language is not present on the objects information, English is used. English: Always uses English. Local : Uses the Local language present on C-MAP BY JEPPESEN C-CARD. If no Local language is available, English is used.

4. After the selection is made, press [CLR] repeatedly or move the ShuttlePoint knob to the left repeatedly until the Chart page is shown.

NOTE

- a. When the Chart Language is changed, the following settings are automatically selected: MODE is set to Off and Chart Language is set to your selection.
- b. If the C-CARD is removed or changed, the Chart Language should be confirmed and changed if necessary.

6.0.9 Pictures & Diagrams

Using optional C-MAP BY JEPPESEN MAX data cards allows you to show pictures or diagrams on the CP180/CP180i and CP300/CP300i display. These *Pictures* are typically used to facilitate the identification of cartographic objects or places around the map: they can be the landscape layout nearby a harbor, the shape of a bridge or of a buoy etc. On some objects, such as bridges, the image associated can represent the *Diagram* representing the shape of the objects and the various characteristics (length, height, type of bridge etc.).

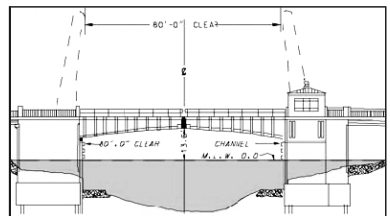



Figure 6.0.9 - Pictures and Diagrams

How to show the pictures or diagrams of a Multimedia Object

They are shown on the Chart page with the camera icon ; see the figure below:

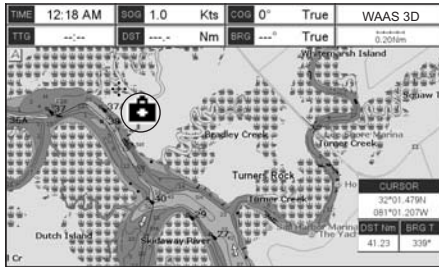

Figure 6.0.9a - Example of camera icon on CP300/CP300i

Move the cursor over the camera icon. You will get the quick info on the object and there is the camera icon on the top bar of the window:

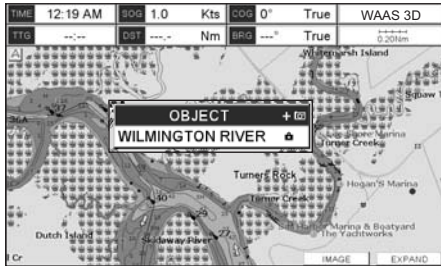

Figure 6.0.9b - Example of Quick Info on camera icon on CP300/CP300i

On the CP300/CP300i press **[IMAGE]**, or on the CP180/CP180i press **[ENT]** for 1 second, to display the image on the screen:



Figure 6.0.9c - Example of displayed image on CP300/CP300i

Otherwise on the CP300/CP300i press **[EXPAND]**, or on the CP180/CP180i press **[ENT]**, to open the Full Info on the object. Note that on the Full Info, there is the small camera icon on a corner of the square containing the object icon. To see the picture press **[MENU]** when the object with a picture is highlighted.

When the picture is shown, it is possible to fit it to screen by pressing **[ENT]**, to change the contrast by pressing **[ZOOM IN]** or **[ZOOM OUT]** and to display the next picture associated, if any, by moving the ShuttlePoint knob left or right.

6.0.10 Enhanced Port Info

Optional C-MAP BY JEPPESEN MAX C-Cards include additional Port Services that were not present before.

Additional attributes of Port Areas and Port Marinas have been included as Location, Country, Region, State, Harbour master telephone number etc., see the following figure.

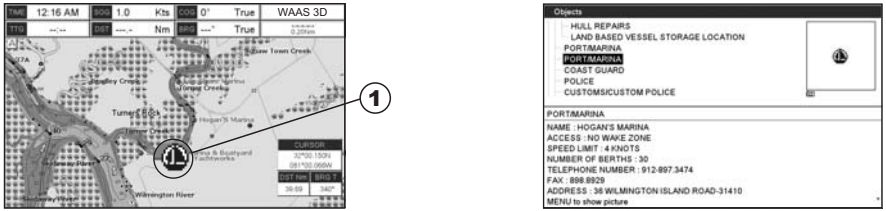

① PORT icon

Figure 6.0.10 - Example of enhanced Port Info

7. CREATING MARKS

Definitions:

MARK

Can be a stand alone position or be linked to a Route. A Mark is place on the Chart page using **[MARK]** or by entering in information in the **MARK/WAYPOINTS** List **NEW MARK** selection.

WAYPOINTS

Always linked to a Route. Are placed on the Chart page using **[ROUTE]**.

NOTE

- The difference between a Mark and a Waypoint is
- When a Route is created using WAYPOINTS and the ROUTE is deleted the WAYPOINTS are also deleted.
 - If a Route is created using MARKS and the ROUTE is deleted the MARKS remain.

7.0 CREATING A NEW MARK USING THE CHART PAGE

1. Move the ShuttlePoint knob to the desired or approx. Lat/Lon and press **[MARK]**.
2. You will notice a Mark is placed under the location of the cursor and a popup window is shown with the exact Lat/Lon of the Mark.
3. If the position is incorrect on the CP180/CP180i press **[ENT]**, select **EDIT** using the ShuttlePoint knob and press **[ENT]**. On the CP300/CP300i, press **[Edit]** that will allow you to change the position, Mark name and icon type.

① Mark placed under Cursor

② Lat/Lon of Mark, DST/BRG from vessel location

ONLY for CP180/180i

Press **[ENT]** to delete, to move, to edit a Mark or to show the Marks/Waypoint List (Directory)

③ Press Soft Key to show the Marks/Waypoint List, to edit, to move or to delete Mark

ONLY for CP300/300i

Press Soft Key to show the Marks/Waypoint List, to edit, to move or to delete Mark

⑤ Vessel location

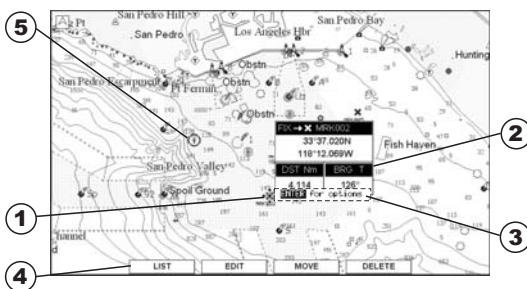

Figure 7.0 - Mark creation

NOTE

After entering in all the Marks it is a good practice to back up the points to an User C-CARD. Refer to Section 11.

7.1 EDITING A MARK

If a Mark has previously been created and you wish to Edit it, move cursor over the top of the Mark.

1. After a Mark is created on the CP180/CP180i press **[ENT]**, move the ShuttlePoint knob to highlight **EDIT** and press **[ENT]**. On the CP300/CP300i press **[EDIT]** to show the edit popup window.



Figure 7.1 - Mark editing

2. The Mark Icon is selected, press **[ENT]**. A popup window appears:

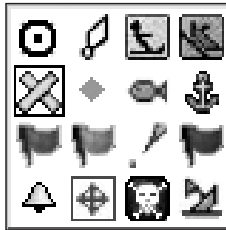

Figure 7.1a - Mark Icons

3. Move the ShuttlePoint knob to select the desired Mark Icon, when finished press **[ENT]**.
4. Move the ShuttlePoint knob to the right to select the Mark Name. Press **[ENT]** and the first digit in the name will be highlighted.
5. Move the ShuttlePoint knob up or down to select the first character.
6. Move the ShuttlePoint knob to the right to select the next character.
7. Repeat steps 4 and 5 until the Mark name is shown. Press **[ENT]**.
8. Move the ShuttlePoint knob to the right to select the Lat/Lon and press **[ENT]**.
9. Move the ShuttlePoint knob up or down to select the first character.
10. Move the ShuttlePoint knob to the right to select the next character.
11. Repeat steps 9 and 10 until the desired position is shown. Press **[ENT]** and **[CLR]** to store the Mark.

7.1.0 Deleting a Mark or Waypoint

1. Move the ShuttlePoint knob over the Mark or Waypoint to delete.
2. On the CP180/CP180i press **[ENT]**, move the ShuttlePoint knob to highlight **DELETE** and press **[ENT]**. On the CP300/CP300i press **[DELETE]**. A popup window will be shown to confirm deleting the point.
3. Move the ShuttlePoint knob to highlight **YES** and press **[ENT]**.

7.1.1 Moving a Mark or Waypoint

1. Move the ShuttlePoint knob over the Mark or Waypoint you want to move.
2. On the CP180/CP180i press **[ENT]**, move the ShuttlePoint knob to highlight **MOVE** and press **[ENT]**. On the CP300/CP300i, press **[Move]**.
3. Use the ShuttlePoint knob to move the cursor. A dotted line, connecting the previous Waypoint position to the new position, is shown:

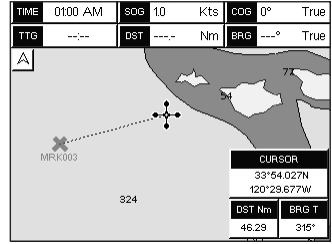
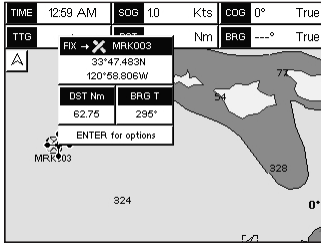

Figure 7.1.1 - Moving Mark or Waypoint (1)

4. Press **[ENT]** (**[CLR]** to abort the move), the Waypoint appears in the new position.

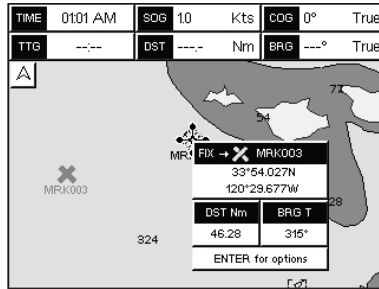

Figure 7.1.1a - Moving Mark or Waypoint (2)

7.2 MARKS/WAYPOINTS LIST

The **MARKS/WPTS** List shows all the Marks and Waypoints that have been stored into the GPS Chart Plotter. This page also allows you to:

ICON	Allows sorting by icon type
FIND	Searches through the Marks or Waypoints to find a point by name using the ShuttlePoint knob
LOCATE	Shows the position of a Mark or Waypoint on the Chart page
EDIT	Allows you to edit a previous stored Mark or Waypoint
SORT	Sorts the name of the Mark or Waypoint in ascending or descending order
NEW MARK	Allows you to create and edit a new Mark. Useful when entering many Marks from a list.
MODE	This selection controls how the Marks or Waypoints are shown on the Chart page. Selections are: a. SHOW - icon and name are shown b. ICON - only icon (no name) is shown c. HIDE - Mark or Waypoint is hidden d. SHOW ALL - All Marks or Waypoints are shown e. ICON ALL - All Icons are shown without name f. HIDE ALL - All Marks or Waypoints are hidden
DELETE*	Opens a window with two options: "DELETE SELECTED" for deleting the selected point and "DELETE ALL" for deleting all stored points.
SEND**	Sends the stored points to a external device (PC) capable of listening to NMEA WPL and RTE sentences.
RECEIVE**	When selected, receives points from an external device (PC) that is capable of sending NMEA WPL sentence.

NOTE*

The CP300/CP300i has two items "DELETE" and "DEL ALL".

NOTE**

The SEND and RECEIVE functions are used to receive or transmit User Points (Marks and Waypoints) to and from a Personal Computer (see also Par. 2.10).

MARKS/WAYPOINTS					
SYM	NAME	TYPE	LATITUDE LONGITUDE	DST(Nm) BRG(T)	MODE
◆	HORIZON	MARK	33°48.328N 118°02.215W	47.57 89°	SHOWN
⊕	MRK002	MARK	33°48.328N 118°58.508W	1.283 37°	SHOWN
⊗	MRK004	MARK	32°57.618N 119°04.178W	49.84 185°	SHOWN
⊙	WPT005	WPT	32°57.618N 119°50.005W	65.21 221°	SHOWN
⊕	WPT006	WPT	33°13.788N 120°13.626W	70.35 242°	SHOWN
ICON		FIND	LOCATE	EDIT	NEW MARK
MODE		DELETE	SORT	SEND	RECEIVE

Figure 7.2 -Example of Marks/Waypoints List

7.3 CREATING A NEW MARK WITH THE USER POINTS LIST

NOTE

This function is very useful if you have a list of Marks that you want to enter into the GPS Chart Plotter.

1. Press **[MENU]**. Move the ShuttlePoint knob to highlight **USER POINTS** and press **[ENT]**.
2. Move the ShuttlePoint knob to highlight **MARKS/WPTS** and press **[ENT]**.
3. The MARKS/WAYPOINTS List page will be shown (see previous Figure).
4. To create a New Mark, move the ShuttlePoint knob to the right to highlight **NEW MARK** and press **[ENT]**.
5. Press **[ENT]** to change to show the Icon popup window.
6. Move the ShuttlePoint knob to highlight the desired Icon and press **[ENT]**.
7. Move the ShuttlePoint knob to the right to select the Mark name. Press **[ENT]** and the first digit in the name will be highlighted.
8. Move the ShuttlePoint knob up or down to select the first character.
9. Move the ShuttlePoint knob to the right to select the next character.
10. Repeat steps 8 and 9 until the Mark name is shown. Press **[ENT]**.
11. Move the ShuttlePoint knob to the right to select the Lat/Lon and press **[ENT]**.
12. Move the ShuttlePoint knob up or down to select the first character.
13. Move the ShuttlePoint knob to the right to select the next character.
14. Repeat steps 12 and 13 until the desired position is shown. Press **[ENT]** and **[CLR]**, a WARNING "Save the new Mark?" popup window will be shown, move the ShuttlePoint knob to the right or left to select **YES** or **NO** and press **[ENT]**.

NOTE

After entering in all the Marks it is a good practice to back up the points to a C-CARD. Refer to Section 11.

7.4 GOTO CURSOR, ROUTE AND MARK

The GPS Chart Plotter allows you to quickly start navigating to the Cursor, Mark or Route.

GOTO CURSOR

1. Move the ShuttlePoint knob to the exact position you want to navigate to.
2. Press **[GOTO]** and a GOTO popup window will be shown.

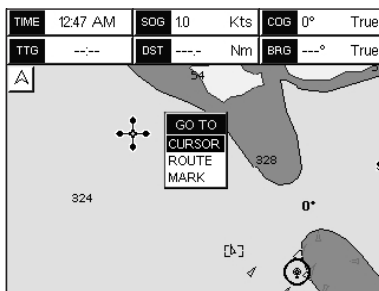

Figure 7.4 - GO TO menu (1)

3. Move the ShuttlePoint knob to highlight **CURSOR** and press **[ENT]**.

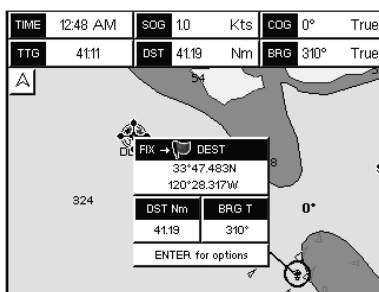

Figure 7.4a - GO TO menu (2)

4. The GPS Chart Plotter is now navigating from your current position to the location selected at step 1. A bearing line between the vessels location and the destination point is shown. A popup window shows the Distance (DST) and Bearing (BRG) from the vessels location to the destination point.

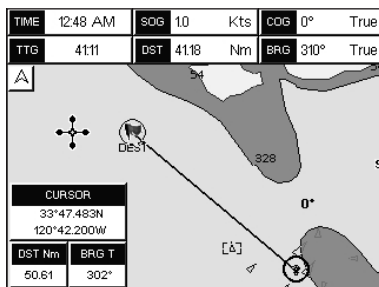

Figure 7.4b - GO TO menu (3)

5. The GPS Chart Plotter is in Cursor mode, to switch to Home mode press **[CLR]** so the vessel will stay in the center of the page.
6. On the CP300/CP300i two Soft Keys are also shown that allow you to quickly switch to the HIGHWAY page or to stop navigation.
7. To STOP Navigation, press **[GOTO]** and the WARNING page is shown. Move the ShuttlePoint knob to highlight **STOP** and press **[ENT]**.

GOTO ROUTE

When a Route is shown on the Chart page, move the cursor over the designed Waypoint and press **[GOTO]**. For more information about Routes refer to Section 9.

GOTO MARK

1. Move the ShuttlePoint knob to an open position (no buoy, warning etc. under the cursor) on the Chart page.
2. Press **[GOTO]** to show the GOTO popup window.
3. Move the ShuttlePoint knob to highlight **MARK** and press **[ENT]** to show the MARKS/WAYPOINTS List.
4. Move the ShuttlePoint to the highlight the desired Mark or Waypoint and press **[GOTO]**.
5. You will notice a circle is drawn around the Icon Symbol. This means the GPS Chart Plotter is now navigating to the point.
6. Press **[CLR]** to switch to the Chart page or Highway page to start navigating to the point.

8. MAN OVER BOARD (MOB) FUNCTION

During navigation, the “MOB” feature provides a one-touch method of storing a location, such as a point were a crew member fell overboard. In this mode, the GPS Chart Plotter places a MOB point on the Chart page and all the navigation data shown is related to navigating back to this point, allowing you to retrace your path to the MOB point efficiently.

8.0 PLACING A MOB POINT

1. On the Chart page, press **[MOB]** to start navigating back to the point.
2. You will notice a MOB Mark will be on the Chart page and all navigation is referring back to this point.
3. On the CP300/CP300i: If the cursor is moved over the MOB Icon, the popup windows over Soft Keys will be shown allowing quick access to the Navigation or Highway pages.

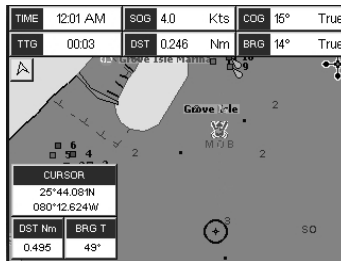

Figure 8.0 - MOB point

8.1 DELETING A MOB POINT

1. Move the ShuttlePoint knob until the cursor is over the top of the MOB icon.
2. On the CP180/CP180i press **[ENT]**, move the ShuttlePoint knob to highlight **DELETE** and press **[ENT]**. On the CP300/CP300i press **[DELETE]**, a popup window will be shown to confirm deleting the MOB point.
3. Move the ShuttlePoint knob to highlight **YES** and press **[ENT]**.

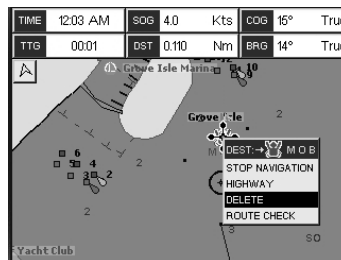



Figure 8.1 - Deleting MOB point

9. ROUTES

The CP180/CP180i and the CP300/CP300i have the capability to store 50 Routes with 100 Waypoints or Marks in each Route.

A Route can consist of Waypoints or Marks. The difference is when a Route is made using Waypoints and the Route is deleted the Waypoints are also deleted. However if a Route is made of Marks and the Route is deleted the Marks stay in memory.

9.0 CREATING A ROUTE USING WAYPOINTS

1. On the Chart page move the ShuttlePoint knob to the Lat/Lon of the starting Waypoint in the Route.
2. Press **[ROUTE]**, you will notice the starting Waypoint  will be placed under the cursor.
3. Move the ShuttlePoint knob to the second Lat/Lon of the next leg  in the Route.
4. Press **[ROUTE]**. You will notice another Waypoint is shown under the cursor and a line joins the starting Waypoint to the Second Waypoint.

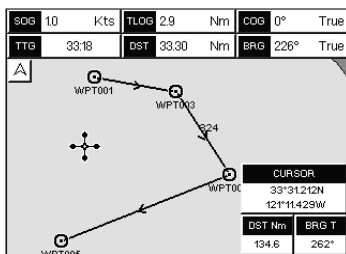

Figure 9.0 - Creating a Route using Waypoints

5. Repeat steps 3 and 4 until all Waypoints are entered into the Route.

NOTE

At this point the Route is saved as ROUTE01. If you would like to save the Route under a specific name follow the next steps.

9.1 CHANGING NAME TO A ROUTE

To name the Route:

1. Press **[MENU]**. Move the ShuttlePoint knob to highlight **USER POINTS** and press **[ENT]**.
2. Move the ShuttlePoint knob to highlight **ROUTE** and press **[ENT]**.
3. Move the ShuttlePoint knob to highlight **REPORT** and press **[ENT]** or move the ShuttlePoint knob to the right.
4. Move the ShuttlePoint knob to highlight **NAME** and press **[ENT]**. A popup window will be shown.
5. Move the ShuttlePoint knob up/down to change the characters and left/right to select a different character in the Routes Name.

ROUTE REPORT						
ROUTE : 1			SPEED : 10.0 Kts			
NAME : ROUTE01			FUEL : 10.0 /h			
WAYPOINT	LATITUDE LONGITUDE	BRG T	LDST Nm	TDST Nm	TIME	FUEL
WPT005	23°11.980N 110°32.819W					
WPT006	23°16.025N	036°	4.064	4.064	000:24	4.05
WPT007	110°31.413W	033°	2.855	6.909	000:41	6.90
WPT008	23°25.760N 110°31.413W	000°	7.347	14.26	001:25	14.2
WPT009	23°36.218N 110°25.406W	028°	11.82	26.08	002:36	26.0

Figure 9.1 - Route Report

- When finished press **[ENT]** to save.
- Press **[CLR]** to show the Chart page.

9.2 CREATING AN OLYMPIC ROUTE

This feature allows the starting point in a Route to be saved as the final destination point.

- On the Chart page move the ShuttlePoint knob to the Lat/Lon of the starting Waypoint in the Route.
- Press **[ROUTE]**, the starting Waypoint will be placed under the cursor.
- Move the ShuttlePoint knob to the second Lat/Lon of the next leg in the Route.
- Press **[ROUTE]**. Another Waypoint is shown under the cursor and a line joins the starting Waypoint to the second Waypoint.
- Repeat steps 3 and 4 until all Waypoints are entered into the Route.

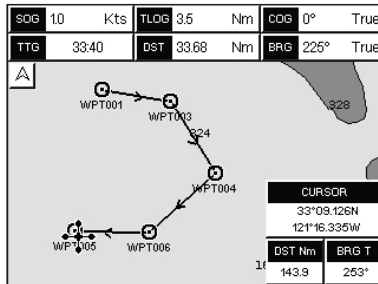

Figure 9.2 - Olympic Route creation (1)

- Then move the ShuttlePoint knob to the last Waypoint and press **[ENT]**.
- Move the ShuttlePoint knob to highlight **OLYMPIC** and press **[ENT]**. A line joins the starting Waypoint and the last Waypoint.

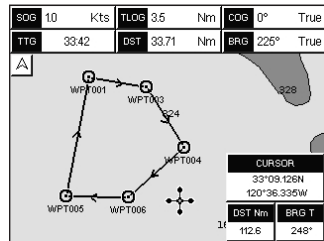
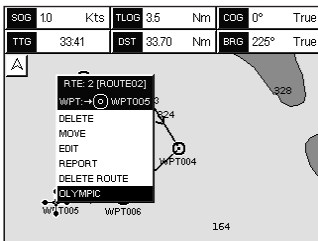

Figure 9.2a - Olympic Route creation (2)

9.3 MAKING ADDITIONAL ROUTES

To create another Route the GPS Chart Plotter must be told that you want to create a second Route.

1. Press **[MENU]**. Move the ShuttlePoint knob to highlight **USER POINTS** and press **[ENT]**.
2. Move the ShuttlePoint knob to highlight **ROUTE** and press **[ENT]**.
3. Move the ShuttlePoint knob to highlight **SELECT** and press **[ENT]** or move the ShuttlePoint knob to the right.
4. Move the ShuttlePoint knob to an open Route number example Route 2.
5. Press **[ENT]** or move the ShuttlePoint knob to the right.
6. Press **[CLR]** or move the ShuttlePoint knob to the left until the Chart page is shown.
7. To create the new Route, follow the steps in Creating a Route using Waypoints or Marks sections.

9.4 CREATING A ROUTE USING MARKS ON THE CHART PAGE

To create a Route containing Marks you first must create the Marks and show them on the Chart page.

1. Move the ShuttlePoint knob over the top of a Mark that you wish to be the starting point in the Route and press **[ROUTE]**.
2. Next move the ShuttlePoint knob until the cursor is over the Mark that you want to be the next leg in the Route.
3. Press **[ROUTE]**. You will notice a bearing line joins the first and second Mark which means these Marks are selected into the Route.
4. Repeat steps 3 and 4 until all Marks are entered into the Route.

NOTE

At this point the Route is saved as ROUTE01. If you would like to save the Route under a specific name follow the remaining steps.

5. To name the Route press **[MENU]**. Move the ShuttlePoint knob to highlight **USER POINTS** and press **[ENT]**.
6. Move the ShuttlePoint knob to highlight **ROUTE** and press **[ENT]**.
7. Move the ShuttlePoint to highlight **REPORT** and press **[ENT]** or move the ShuttlePoint knob to the right.
8. Move the ShuttlePoint knob to highlight **NAME** and press **[ENT]** or move the ShuttlePoint knob to the right. A popup window will be shown.
9. Move the ShuttlePoint knob up/down to change the characters and left/right to select a different character in the Routes Name.
10. When finished press **[ENT]** to save.
11. Press **[CLR]** to show the Chart page is shown.

9.5 INSERTING A WAYPOINT INTO A ROUTE

Place the cursor on the navigation line between two Waypoints and press **[ROUTE]**. The line between the two Waypoints is turned into a dotted line, see the following picture.

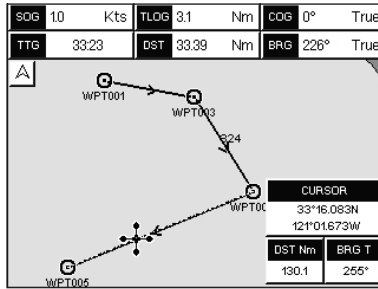

Figure 9.5 - Inserting Waypoint procedure (1)

Move the ShuttlePoint knob to the desired location for the new Waypoint: the line will “rubber-band”, drawing a dotted line between the previous Waypoint and the cursor, and another dotted line between the cursor and the next Waypoint (see the left side of the above picture). Once you have positioned the cursor at the location you want, press **[ENT]** (see the right side of the above picture).

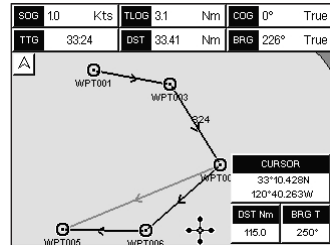
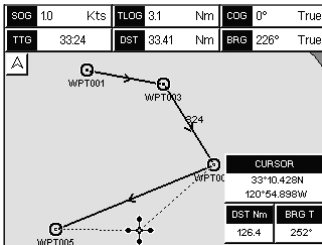

Figure 9.5a - Inserting Waypoint procedure (2)

9.6 GOTO A ROUTE

9.6.0 By select Route

1. Move the ShuttlePoint knob to an open position (no buoy, warning etc. under the cursor) on the Chart page.
2. Press **[GOTO]** to show the GOTO popup window.
3. Move the ShuttlePoint knob to highlight **ROUTE** and press **[ENT]**.
4. The SELECT ROUTE popup window will be shown.

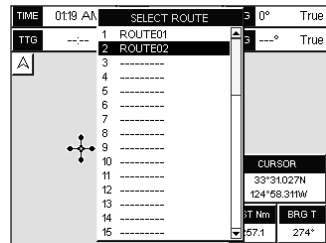
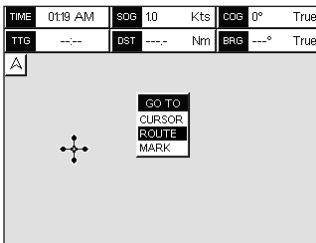

Figure 9.6.0 - GOTO ROUTE procedure (1)

5. Move the ShuttlePoint knob to highlight the desired Route and press **[ENT]**.
6. On the Chart page a circle with a Flag is shown on the first leg of the Route and a navigation line is shown, indicating the GPS Chart Plotter is navigating to the first Waypoint in the Route.

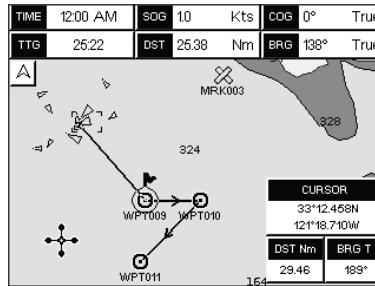

Figure 9.6.0a - GOTO ROUTE procedure (2)

9.6.1 By Cursor key

1. On the Chart page move the ShuttlePoint knob until the cursor reaches the starting point of the Route.
2. Press **[GOTO]** to start following the Route.
3. Press **[CLR]** twice to revert to Home mode.

9.7 DELETING A ROUTE

To delete a Route follow the procedure below:

1. Press **[MENU]**. Move the ShuttlePoint knob to highlight **USER POINTS** and press **[ENT]**.
2. Move the ShuttlePoint knob to highlight **ROUTE** and press **[ENT]**.
3. Move the ShuttlePoint knob to highlight **DELETE** and press **[ENT]** or move the ShuttlePoint knob to the right.
4. A Warning message appears to confirm. Move the ShuttlePoint knob to highlight **YES** and press **[ENT]**. The Route has been deleted.

WARNING

An active Route (one that you are navigating to) cannot be deleted until you stop navigating to the Route.

9.8 OTHER SETTINGS IN ROUTE MENU

You will notice the **ROUTE** menu has other selections.

SELECT	Choose an available Route to create or choose a stored Route to show and follow on the Chart page.
REVERSE	Reverses the Route, when chosen Starting point is at the end of the Route.
COLOR	Allows changing the color of the navigation lines between each leg in the Route.
REPORT	The Route Report menu is useful to show details of the Waypoints contained within the Route. This menu also allows you to enter in your average speed and fuel consumption and calculate the approximate fuel used when following the Route.
SEND	Sends the stored points to an external device (PC) capable of listening to NMEA RTE sentence.
RECEIVE	Receive the points from an external device (PC) capable of sending NMEA RTE sentence.
THICKNESS	Selection that allows the Route line to be easily seen; default selection is Thick.

9.8.0 Route Check

The Route Check function is used after you have created a Route to ensure you and your vessel will not have problems while navigating. This is done by the CP180/CP180i and CP300/CP300i by reviewing the Route and looking for the following hazards that may effect safe navigation.

- Land Areas
- Shallow Water
- Intertidal Areas (*areas emerged at low tide*)
- Rocks
- Wrecks
- Obstructions
- Shoreline Constructions
- Fishing Facility
- Dredged Areas
- Diffusers (*submarine pipeline*)
- Mooring/Warping Facility
- Production Installation (*an installation for the exploitation of natural resources*)
- Pingos (*small conical hills having a large central core of ice formed from the encroachment of permafrost and the resulting hydrostatic pressure*)
- No Data Available (*no adequate data coverage*)

If any of these alarm conditions is detected, the function returns the list of dangerous objects and the relative dangerous Route leg, that is drawn with a different color.

- Route legs which were classified as dangerous are displayed in RED. It means that there is at least one dangerous object in the vicinity of this leg and it has been found.
- Route legs which were classified as safe are displayed in GREEN. It means that the data was checked on detailed map levels and no problems were found for all segments of the leg.
- Route legs for which there was not sufficient data to be checked are displayed in YELLOW. It means that no problems were found but the data was not sufficient or not available at all to classify such a leg as safe.

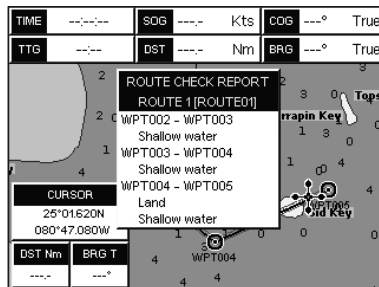

Figure 9.8.0 - Example of dangerous objects found on the chart

To activate this function:

- | | |
|------------------------|---|
| AUTOMATIC CHECK | Turns the Route Checking feature On or Off. Turn the Automatic Route Check on after you have created a new Route, or if you inserted a new Waypoint, deleted, moved or edited any Waypoint in a saved Route to confirm the Route can be safely navigated. |
|------------------------|---|

ROUTE WIDTH	This selection allows you to select the width from the left and right of the Route leg where the GPS Chart Plotter will check to confirm navigation threats. See the picture below. The default for this selection is 0.04NM.
DEPTH LIMIT	This selection allows you to select the water depth in the Route width area so the GPS Chart Plotter can check and confirm underwater threats. It checks if some objects with the depth attribute (like Shallow Water, Dredged Areas, Diffusers, Obstructions, Pingos, Production Installation, Wreck) are above this depth level. Only if the depth attribute is above the depth limit are they found and considered as dangerous. See the picture below. The default setting is 10FT.
ACCURACY	Defines a segment length into which a leg of the Route is divided in order to execute the search for dangerous objects with better accuracy. When accuracy is maximal, a segment length is the shortest. When accuracy is minimal, a segment length is the longest. Selects among Minimum, Low, Medium, High and Maximum. See the picture below. The default setting is Medium.
ROUTE CHECK REPORT	Shows the list of the dangerous objects found on the charts crossed by the Route.

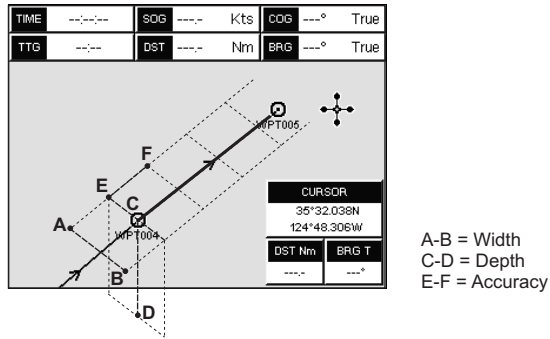

Figure 9.8.0a - Route Check parameters

NOTE

Although the functionality is called Route Check, it can also be activated when the navigation is set to a single point (like DSC, MOB, Mark). In the case of checking a single point towards which the navigation is started, the leg for which the Route Check is executed is defined by the current position (the leg's starting point) and the destination point (the leg's ending point).

10. TRACKS

The CP180/CP180i and the CP300/CP300i have the capability to store 20 individual tracks and record up to 10,000 Track Points.

Before using the Track function you will need to setup the Track function that suits your boat. The Track function tracks your vessels location as it moves through the water. The Track function can be setup to lay down a Track for a predetermined time or distance interval. If you have a fast moving boat you may want to setup the CP180/CP180i or CP300/CP300i to record a Track point every 0.5NM or if you have a sail boat you may want to setup to lay down a Track point once every 1 minute.

NOTE

Please note the Track point memory capacity is 10,000 points. This means for a long journey you may have to adjust the time or distance to be able to track your journey. It should be noted when the 10,000 Track points are used up, the first Track point layed down will be deleted when a new point is placed on the chart.

1. Press **[MENU]**. Move the ShuttlePoint knob to highlight **USER POINTS** and press **[ENT]**.
2. Move the ShuttlePoint knob to highlight **TRACK** and press **[ENT]**.
3. Move the ShuttlePoint knob to highlight **STEP UNIT** and press **[ENT]** or move the ShuttlePoint knob to the right.
4. Move the ShuttlePoint knob to highlight **Dist** or **Time** and press **[ENT]** or move the ShuttlePoint knob to the right.

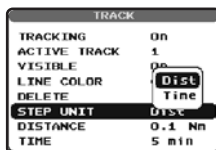

Figure 10 - Distance Units and Time Units

5. Move the ShuttlePoint knob to highlight **DISTANCE** or **TIME** step interval and press **[ENT]** or move the ShuttlePoint knob to the right.
6. Move the ShuttlePoint knob up/down to the desired step value and press **[ENT]** or move the ShuttlePoint knob to the right.
7. Press **[CLR]** or move the ShuttlePoint knob to the left until the Chart page is shown.

10.0 TRACKING

You may have to take a few trips to see how you like the Distance or Time Interval setup on the previous step. However when using the tracking feature you will notice every time a Track Point is layed down on the Chart page a small filled in circle is shown on the Track line. If you move the cursor over the top of the circle a popup window will be shown with the Time, Water Temperature (shown when FF525 (or FF520) is connected), Speed and Course Over Ground (COG) this is very useful if you are fishing and want to review the conditions where the fish were being caught.

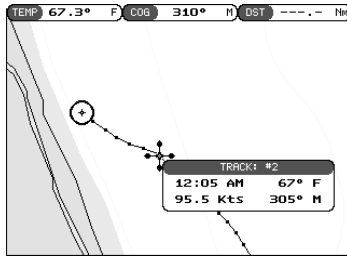

Figure 10.0 - Tracking

10.0.0 Saving and starting a new Track

A Track is automatically saved to memory. To start a new Track:

1. Press **[MENU]**. Move the ShuttlePoint knob to highlight **USER POINTS** and press **[ENT]**.
2. Move the ShuttlePoint knob to highlight **TRACK** and press **[ENT]**.
3. Move the ShuttlePoint knob to highlight **ACTIVE TRACK** and press **[ENT]** or move the ShuttlePoint knob to the right.
4. Move the ShuttlePoint knob up/down to select the next available open Track and press **[ENT]** or move the ShuttlePoint knob to the right.
5. Move the ShuttlePoint knob to highlight **TRACKING** and press **[ENT]** or move the ShuttlePoint knob to the right to set On.
6. Press **[CLR]** or move the ShuttlePoint knob to the left until the Chart page is shown.
7. A new Track now will be laid down.

10.0.1 Other Settings in Track Menu

You will notice the Track menu has other selections:

TRACKING	Allows turning on or off the tracking function
ACTIVE TRACK	This selection allows you to save a Track to one of the 5 Tracks available
VISIBLE	Shows or hides a Track shown in ACTIVE TRACK menu
LINE COLOR	Selects the color of the Track line
DELETE	Deletes a Track selected in the ACTIVE TRACK menu
STEP UNIT	Allowable selection are Distance or Time
DISTANCE	User adjustable Distance interval of when Track point is laid down on the Chart page.
TIME	User adjustable Time interval of when Track point is laid down on the Chart page.

10.1 USING THE TRIP LOG

On the Chart, Navigation, Highway and NMEA Data pages the windows may be customized to show TRIP LOG information.

1. Select one of the pages listed above, press and hold **[MENU]**. You will notice one of the data boxes will be highlighted.
2. Press **[ENT]** and move the ShuttlePoint knob to highlight **TRIP LOG**, press **[ENT]** or move the ShuttlePoint knob to the right.
3. A popup window will be shown with **Nm** (Nautical Mile), **Sm** (Statute Mile), **Km** (Kilometer) and **RESET**. Move the ShuttlePoint knob to select the desired units of measure and press **[ENT]** or move the ShuttlePoint knob to the right.

- Press **[CLR]** or move the ShuttlePoint knob to the right until the selected page (Chart, Navigation, Highway or NMEA Data Page) is shown.

10.1.0 Trip Log selection / Reset

When Trip Log is selected in one of the data windows and you want to reset the log:

- Press and hold **[MENU]** until a field is highlighted (it will be shown in a yellow frame).
- Move the ShuttlePoint knob to highlight the Trip Log window **TLOG** and press **[ENT]**.
- A popup window will be shown. Move the ShuttlePoint knob to **TLOG** and press **[ENT]**.
- Another popup window will be shown. Move the ShuttlePoint knob to **RESET** and press **[ENT]**.
- A warning popup window will be shown to confirm if you want to reset the Trip Log. Move the ShuttlePoint knob to **YES** and press **[ENT]**. The Trip Log is now reset.
- Press **[CLR]** to store and exit the editing mode

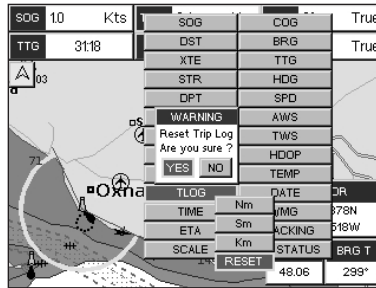

Figure 10.1. 0 - Trip Log Reset

11. USER C-CARD

The optional User C-CARD is used to back up Marks, Routes, and Tracks stored in your GPS Chart Plotter's memory. In the USA the User C-CARD is available directly from Jeppesen Marine at 800/424-2627. The User C-CARD is similar to a back up disk used with a PC, in case you have to clear the RAM to resolve an issue or load new software or if your CP180/CP180i and CP300/CP300i becomes stolen, or if you would like to transfer Waypoint, Track and Route information from one STANDARD HORIZON GPS Chart Plotter to another.

11.0 USER C-CARD MENU

This optional card is similar to using a floppy disk or memory stick on a PC to backup your files or to transfer the information that you have stored to a friends GPS Chart Plotter. The information shown below will assist you to transfer the User Points, Routes and Track history to the optional User C-CARD.

- ① Time of file creation
- ② Date of file creation
- ③ Type of data contained in the file (Mark file, Waypoint file...)
- ④ File name
- ⑤ Number of Selected file
- ⑥ Information on stored User Points on Internal Memory

FILE	NAME	TYPE	DATE	TIME
0	JFILE06	TRACKS	01/01/80	00:00:00
	FILE02	MARKS	01/01/80	00:00:00
MRKS	FILE07	TRACKS	01/01/80	00:00:00
6	FILE04	MARKS	01/01/80	00:00:00
	JFILE0710	TRACKS	01/01/80	00:00:00
WPTS	GILE06	TRACKS	01/01/80	00:00:00
2	GILE07	TRACKS	01/01/80	00:00:00
	FILE08	MARKS	07/02/98	17:17:00
RTES	FILE09	ROUTES	07/02/98	17:17:00
1	FILE01	TRACKS	01/01/80	00:00:00
TRKS	FILE03	MARKS	01/01/80	00:00:00
20	FILE05	MARKS	01/01/80	00:00:00

SAVE LOAD DELETE FORMAT REFRESH

Figure 11.0 - User C-CARD Menu

11.0.0 Formatting the User C-CARD

1. Press **[MENU]**. Move the ShuttlePoint knob to highlight **USER POINTS** and press **[ENT]**.
2. Move the ShuttlePoint knob to highlight **USER C-CARD** and press **[ENT]**.
3. Move the ShuttlePoint knob to highlight **FORMAT** and press **[ENT]**.
4. A popup Warning window will to confirm you want to format the User C-CARD.
5. Select **YES** and press **[ENT]** to confirm (select **NO** otherwise). The format of User C-CARD must be done before using a new User C-CARD: this operation prepares the User C-CARD to receive and store information.

NOTE

Formatting permanently erases all files previously saved on the User C-CARD.

11.0.1 Transferring files to the optional User C-CARD

1. Remove a C-MAP BY JEPPESEN NT+/MAX C-CARD if present and insert the optional User C-CARD into the slot.

2. Press **[MENU]**. Move the ShuttlePoint knob to highlight **USER POINTS** and press **[ENT]**.
3. Move the ShuttlePoint knob to highlight **USER C-CARD** and press **[ENT]**.
4. A screen will appear. Move the ShuttlePoint knob to the left to highlight **SAVE** and press **[ENT]**.
5. A popup **SAVE FILE** window will appear. In this window you can change the name and the file type by using the ShuttlePoint knob and pressing **[ENT]**, when finished press **[CLR]** once.
6. To save the file, move the ShuttlePoint knob to **SAVE** in window and press **[ENT]**.
7. A Information pop window will momentarily be shown "SAVING" then show **SAVING OK**.
8. Press **[ENT]** to confirm.

11.0.2 Loading a file

If you have a problem and accidentally loose the User Points in the GPS Chart Plotter with the optional User C-CARD it is possible to load the data back into the GPS Chart Plotter using the following procedure:

1. Press **[MENU]**. Move the ShuttlePoint knob to highlight **USER POINTS** and press **[ENT]**.
2. Move the ShuttlePoint knob to highlight **USER C-CARD** and press **[ENT]**.
3. Select the saved file from the User C-CARD list by using the ShuttlePoint knob and press **[ENT]**.
4. Move the ShuttlePoint knob to the left to highlight **LOAD** and press **[ENT]**.
5. A popup information window will appear when loading is complete.
6. Press **[ENT]** to confirm.

11.0.3 Deleting a file from the User C-CARD

You may want to delete a saved file on the User C-CARD.

1. Press **[MENU]**. Move the ShuttlePoint knob to highlight **USER POINTS** and press **[ENT]**.
2. Move the ShuttlePoint knob to highlight **USER C-CARD** and press **[ENT]**.
3. Select the saved file from the User C-CARD list by using the ShuttlePoint knob and press **[ENT]**.
4. Move the ShuttlePoint knob to the left to highlight **DELETE** and press **[ENT]**.
5. A popup Warning window will to confirm you want to delete the file.
6. Press **[ENT]** to confirm.

11.0.4 Refreshing the User C-CARD

You may want to change the User C-CARD inserted in the slot with a new one.

1. Press **[MENU]**. Move the ShuttlePoint knob to highlight **USER POINTS** and press **[ENT]**.
2. Move the ShuttlePoint knob to highlight **USER C-CARD** and press **[ENT]**.
3. Open the door, remove the User C-CARD from the slot and insert another User C-CARD into the same slot.
4. Move the ShuttlePoint knob to highlight **REFRESH** and press **[ENT]**. This "new" User C-CARD is now ready to receive and store information.



12. PAGES

The GPS Chart Plotter has many pages that are designed to ease your navigation.

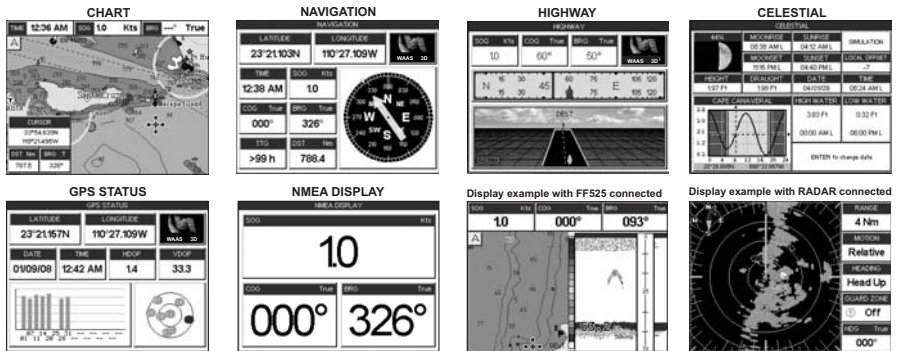

Figure 12 - Screen display pages example

The pages can be selected in the following way:

Selection by MENU

This function is available on the CP180/CP180i and CP300/CP300i.

1. Press **[MENU]**. The following page is shown on the screen:



Figure 12a - Main Menu on CP180/CP180i

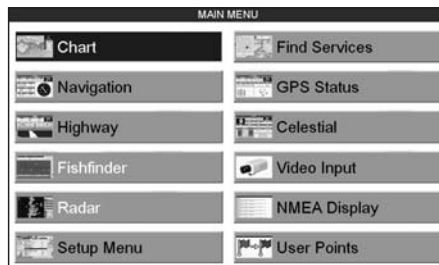

Figure 12b - Main Menu on CP300/CP300i

2. Move the ShuttlePoint knob to highlight the desired page and press **[ENT]**.

Selection by SOFT KEY ONLY For CP300/CP300i

Press one of the Soft Keys under the display, then press the Soft Key to show the desired page.

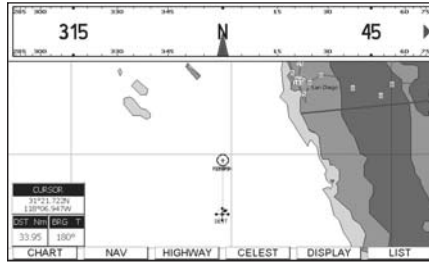

Figure 12c - Screen display pages selection by Soft Keys on CP300/CP300i

12.0 CHART PAGE

The Chart page is the main page of the GPS Chart Plotter. From this page the user can zoom in/out, pan around the chart, show information about cartographic objects, see the exact vessel position with the COG and SOG, place points, GOTO a destination point, show Track history etc. The GPS Chart Plotter is provided with a Worldwide background showing C-MAP By JEPPESEN NT*/MAX detail up to 2.0 NM. For more detail, optional C-MAP By JEPPESEN NT*/MAX C-CARDS are used.

It is possible to set the chart as a single or two charts side by side.

1. Press **[MENU]**. Move the ShuttlePoint knob to highlight **CHART** and press **[ENT]**. Two Chart page types are available: Single and Dual.
2. Move the ShuttlePoint knob to highlight **Single** or **Dual** and press **[ENT]**.

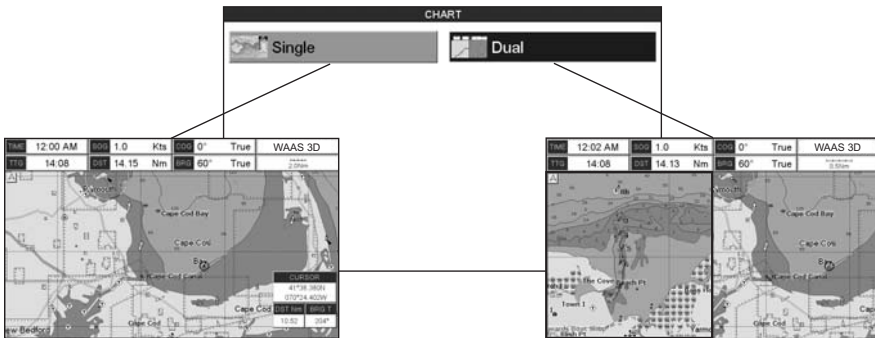

Figure 12.0 - Chart selection menu on CP300/CP300i

NOTE

An "egg timer" symbol may appear on the unused window of the Dual Chart page. It happens when the chart plotter updates the displayed map in the not active window. So the user understands that the chart plotter is busy.

For CP300/CP300i
Focus Soft Key on Dual Chart page

When the Dual Chart page has been selected, the active window is highlighted by a "red" boarder around the window. The keyboard commands are related to that focused view. To move the focus to a different window follow the procedure:

1. Press any Soft Key. The Soft Key labels appear on the bottom of the screen. A **[Focus]** Soft Key will be shown.

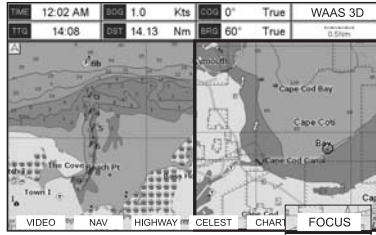

Figure 12.0a - Example of Dual Chart page with **[Focus]** shown

2. Press **[Focus]**. A popup window appears where the active focus window label is highlighted.

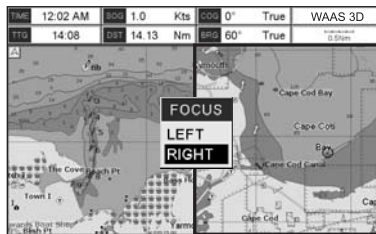

Figure 12.0b - Example of Dual Chart page with **[Focus]** window shown

3. Move the ShuttlePoint knob up and down to highlight the desired item and press **[ENT]**. The red boarder is moved to the focused window.

For CP180/CP180i
Change Focus on Dual Chart page

When the Dual Chart page has been selected, the active window is highlighted by a "red" boarder around the window. The keyboard commands are related to that focused view. To move the focus to a different window follow the procedure:

1. Press and hold **[INFO]** for 2 seconds. The "red" boarder around the window is moved from active window to the other.
Repeat the step 1. to move the focus from a window to another.

Single Chart page

- ① Fix Status
- ② Cursor coordinates
- ③ Speed Over Ground and Course Over Ground
- ④ Bearings from Fix to Cursor (if the Fix is NOT received, BRG is empty)
- ⑤ Trip Log
- ⑥ Distance from Fix to Cursor (if the Fix is NOT received, DST is empty)
- ⑦ Chart Scale

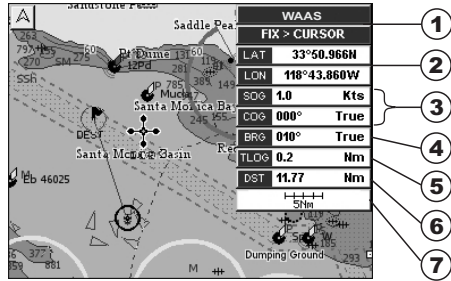

Figure 12.0c - Example of Charts and general text area in the Single Chart page

12.0.0 Window Selections

The window on the right side of the Chart page is called the General Window and it may be edited, customized or even changed to show a highway or compass tape.

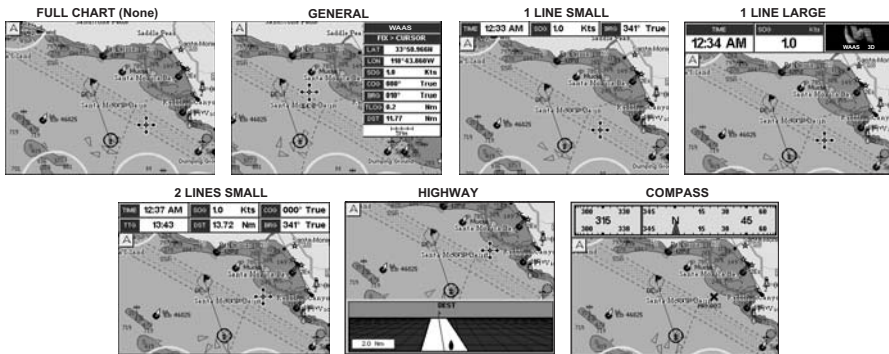

Figure 12.0.0 - Data window layout

1. To change, press **[MENU]**. Move the ShuttlePoint knob to highlight **SETUP MENU** and press **[ENT]**.
2. Move the ShuttlePoint knob to highlight **GENERAL SETUP** and press **[ENT]** or move the ShuttlePoint knob to the right.
3. Move the ShuttlePoint knob to highlight **WINDOW SETUP** and press **[ENT]** or move the ShuttlePoint knob to the right.
4. Move the ShuttlePoint knob to highlight **CHART PAGE** and press **[ENT]** or move the ShuttlePoint knob to the right.
5. Select the desired window, **HIGHWAY** or **COMPASS**, and press **[ENT]** or move the ShuttlePoint knob to the right.
6. Press **[CLR]** or move the ShuttlePoint knob to exit the menu and show the Chart page.

12.0.1 Customizing the Data Windows

The data fields contained on the General, 1 Line Small/Large and 2 Line Small data windows can be changed to the following selections:

- SOG = Speed Over Ground
- COG = Course Over Ground
- DST = Distance
- BRG = Bearing
- XTE = Cross Track Error
- TTG = Time To Go
- STR = Steering
- HDG = Heading from Electronic Compass
- DTP = Depth
- SPD = Speed
- ALT = Altitude
- AWS = Apparent Wind Speed
- AWD = Apparent Wind Direction
- TWS = True Wind Speed
- TWD = True Wind Direction
- HDOP = Horizontal Dilution of Precision
- VDOP = Vertical Dilution of Precision
- Temp = Water Temperature
- TLOG = Trip Log
- DATE = Current Date
- TIME = Current Time
- VMG = Velocity Made Good
- ETA = Estimated Time of Arrival
- TRACKING = Tracking
- SCALE = Chart Scale
- GPS Status = Shows GPS Fix Status (WAAS, 3D, 2D, ...)

To select the desired field, follow the procedure:

1. Press and hold **[MENU]** until a field is highlighted (it will be shown in a yellow frame).
2. Move the ShuttlePoint knob to the desired data field (the yellow frame is moved to the desired data field) and press **[ENT]**. The popup window will be shown.
3. Move the ShuttlePoint knob up/down or left/right to choose the desired setting and press **[ENT]**.
4. Press **[CLR]** to store and exit the editing mode.

NOTE

Data window field on the NAVIGATION, HIGHWAY, GPS STATUS, and NMEA pages may be customized in the above manner.

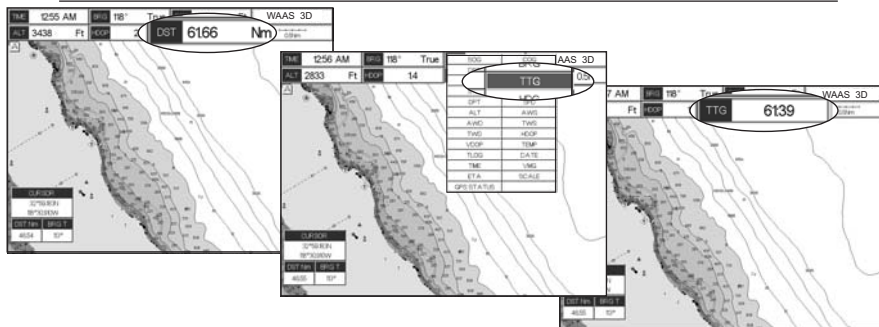

Figure 12.0.1 - Customizing the Data Windows

NOTE

See Par. 10.1.0 if Trip Log is selected in one of the data windows and you want to reset the log.

12.0.2 Additional Functions on Chart page

When on the Chart page you will notice icons of Buoys, Towers, Lights, Wrecks, Tide Stations and Port Icons. If the cursor is moved over the top of these icons a popup window will be shown with information about the icon.

12.0.3 Turning Off Information on Icon Points

The GPS Chart Plotter allows you to select to see information on points, on all items or to turn this function off. The default setting is On Points.

1. Press **[MENU]**. Move the ShuttlePoint knob to highlight **SETUP MENU** and press **[ENT]**.
2. Move the ShuttlePoint knob to highlight **GENERAL SETUP** and press **[ENT]** or move the ShuttlePoint knob to the right.
3. Move the ShuttlePoint knob to highlight **AUTO INFO** and press **[ENT]** or move the ShuttlePoint knob to the right.
4. Move the ShuttlePoint knob up or down to highlight **OFF**, **ON POINTS** or **ON ALL** and press **[ENT]** or move the ShuttlePoint knob to the right.
5. Press **[CLR]** or move the ShuttlePoint knob to the left until the Chart page appears.

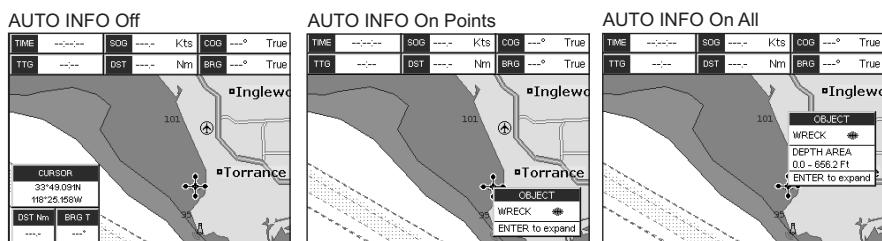

Figure 12.0.3 - Example of Auto Info settings

12.0.4 Display Mode

Selects from a pre-defined table what cartographic objects are displayed and which display options are set. Pre-programmed settings are user selectable from Full, Medium, Low, Radar (reduces the information on the display to simulate items that would be shown on a RADAR display. Please note this function is not actually showing RADAR information it is only showing what typically would be shown by a separate dedicated RADAR display), Tides, Custom (default mode).

To change to one of the pre-programmed settings

1. Press **[MENU]**. Move the ShuttlePoint knob to highlight **SETUP MENU** and press **[ENT]**.
2. Move the ShuttlePoint knob to highlight **MAP CONFIGURATIONS** and press **[ENT]** or move the ShuttlePoint knob to the right.
3. Move the ShuttlePoint knob to highlight **DISPLAY MODE** and press **[ENT]** or move the ShuttlePoint knob to the right.
4. Move the ShuttlePoint knob up or down to select the preset and press **[ENT]**.
5. Press **[CLR]** or move the ShuttlePoint knob to the right until the Chart page is shown.

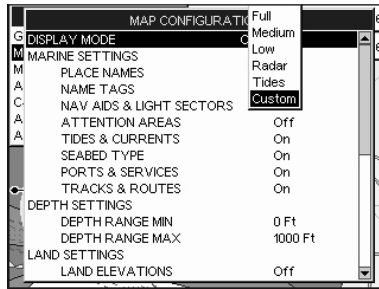

Figure 12.0.4 - Display Mode settings

The table below shows the selections for each mode:

Setting	Full	Medium	Low	Radar	Tides	Custom (Default values)
Place Names	On	On	On	On	On	On
Name Tags	On	Off	Off	Off	Off	On
Nav Aids & Light Sectors	On	No Sectors	No Sectors	No Sectors	Off	On
Attention Areas	On	On	Off	Off	Off	Off
Tides & Currents	On	Off	Off	Off	On	On
Seabed Type	On	Off	Off	Off	Off	On
Ports & Services	On	On	Off	On	Off	On
Tracks & Routes	On	Off	Off	Off	Off	On
Depth Range Min	0FT	0FT	0FT	0FT	0FT	0 Ft
Depth Range Max	32804FT	32804FT	32804FT	32804FT	32804FT	1000FT
Land Elevations	On	On	Off	Off	Off	Off
Land Elevation Values	On	Off	Off	Off	Off	On
Roads	On	Off	Off	Off	Off	On
Points Of Interest	On	Off	Off	Off	Off	On
Lat/Lon Grid	On	Off	Off	Off	Off	Off
Chart Boundaries	On	Auto	Off	Off	Off	Off
Value-Added Data	On	Off	Off	Off	On	On
Chart Lock	On	On	On	On	On	On
Mixing Levels	On	On	On	On	On	On
Underwater Ob. Limit	1000FT	32FT	32FT	32FT	32FT	10FT
Rocks	Icon + Depth	Icon	Icon	Icon	Icon	Icon
Obstructions	Icon + Depth	Icon	Icon	Icon	Icon	Icon
Diffusers	Icon + Depth	Icon	Icon	Icon	Icon	Icon
Wrecks	Icon + Depth	Icon	Icon	Icon	Icon	Icon

12.0.5 Marine Settings

To control the display on the map of the marine features.

Place Names	: Turns the Local area names On or Off.
Names Tags	: Turns a tag for particular chart objects that either includes the Name of the chart object or the Depth of an Underwater chart object On or Off.
Nav Aids & Light Sectors:	Turns the presentation of Lights, Signals, Buoys and Beacons On (Nav Aids & Light Sectors are shown), Off (Nav Aids & Light Sectors are not shown) or No Sector (Nav Aids are shown, Light Sectors are hidden).
Attention Areas	: Turns the displaying of Attention Areas (areas in which special attention by the mariner is required because of natural or man-made hazards sailing regulations and restrictions) On or Off.
Tides & Currents	: Turns the displaying of Tides and Currents On or Off. When data/time is available, Tidal stream arrows are shown on the charts, indicating the direction and strength of the Tide. If no data/time is available from the GPS or the GPS Chart Plotter is not in Simulation mode, the icon on the map is generic one. The color of the arrow denotes the strength of the current as follows:

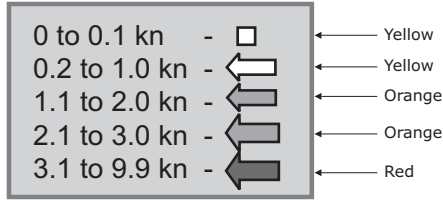

When the GPS Chart Plotter receives a valid position fix, the Tide icons are shown on the charts on the basis of the current date and time: the screen displays and changes arrows as date/time changes.

- Seabed Type** : Turns the displaying of the Seabed type On or Off.
- Ports & Services** : Turns the displaying of Ports and Service icons On or Off. Areas along the shore with facilities for mooring, downloading and uploading of ships, generally sheltered from waves and winds. Port installations are piers, wharves, pontoons, dry docks, cranes....
- Tracks & Routes** : Turns displaying of underwater objects On or Off. Objects are obstructions, wrecks, cable etc.

12.0.6 Depth Settings

To control the display on the map of the depth informations.

- Depth Range Min** : Sets the minimum depth limit to show Depth Sounding, Bathymetric Lines and Depth Area. The default setting is 0FT.
- Depth Range Max** : Sets the max depth limit to show Depth Sounding, Bathymetric Lines and Depth Area. The default setting is 1000FT.

0-1000 Ft

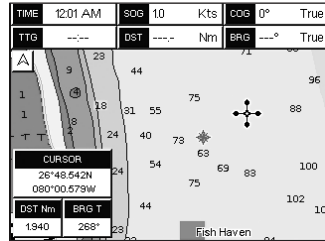

50-100 Ft

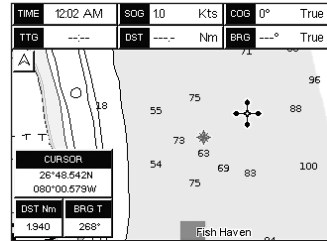
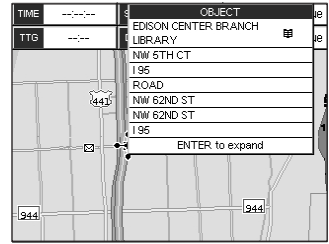
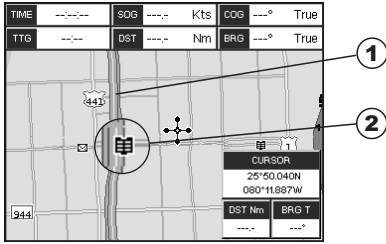

Figure 12.0.6 - Depth Settings

12.0.7 Land Settings

To control the display on the map of the terrestrial features.

- Land Elevations** : Turns the displaying of Land Elevations On or Off.
- Land Elevation Values** : Turns the displaying of Land Elevation Values On or Off.
- Roads** : Turns the displaying to roads On or Off.
- Points of interest** : Turns the displaying of Points of Information On or Off.



- ① ROAD
- ② POINT OF INTEREST (LIBRARY)

Figure 12.0.7 - Example of Roads and Points Of Interest

12.0.8 Chart Settings

Settings that control how the chart features will be shown on the Chart page of the GPS Chart Plotter.

Lat/Lon Grid : Turns the displaying of the Latitude and Longitude grid lines On or Off on the Chart page. See the figure below:

Lat/Lon Grid ON

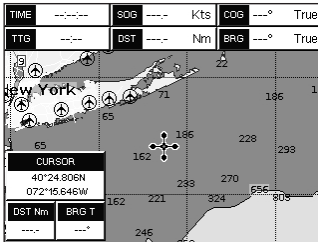

Lat/Lon Grid OFF

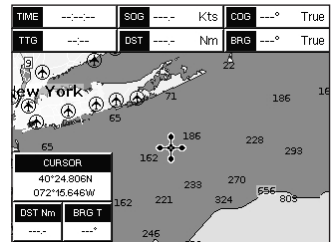

Chart Boundaries : Turns the displaying of Chart Boundaries On, Off or Auto. The Chart Boundaries are the "ticked" boxes surround the coastline. Each box indicates an area where more detail is available. The Chart Boundaries are only show when a C-MAP By JEPPESEN NT, NT* or MAX CARD is inserted into the GPS Chart Plotter. See the figure below:

Chart Boundaries ON

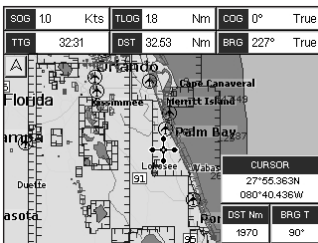
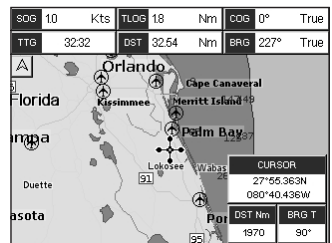
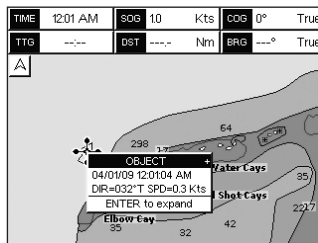
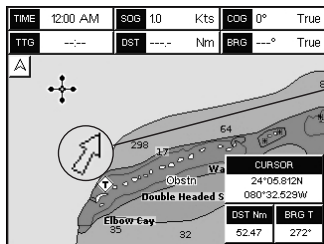

Chart Boundaries OFF



Value Added Data : Turns the displaying of Value added data On or Off. The Value Added Data (VAD) is a collection of additional cartographic objects which are not present on the original paper chart (from which the electronic chart derives). These objects have been obtained from other sources and then merged to the electronic charts in order to provide more information useful for the navigation. VAD object can be any cartographic objects and it can be distinguished from the official-chart-objects

from the Quick Info. A dedicated icon is shown on the Quick Info window to indicate that the object queried is a VAD. The same icon is also shown on the Full Info page and in addition the extended text Value Added Data is shown on the details of the VAD object. See the figure below:



① Example of VAD object

- Chart Lock (*)** : Turns the chart function On/Off. When Chart Lock is On, the available zoom scales are only the ones containing cartographic data. Instead when Chart Lock is Off, it is possible to zoom down into zoom scales not covered by cartographic data after the last available zoom scale covered by cartographic data. The DSI (Data Safety Indicator) window, if present, will show "NO CHART", when an empty level is entered in the location of map expansion mode.
- Mixing Levels** : When the map coverage at the current chart scale does not fill the entire display, the GPS Chart Plotter draws the rest of the map using charts from above and below the current scale. When this function is turned on you will notice the display may redraw 2 to 3 times to show all the details.

NOTE(*)

When an empty level is entered, the message "No cartographic coverage" is shown on a window in a corner of the map display. The warning message is always displayed as long as the current zoom has no data coverage.

12.0.9 Underwater Objects Settings

To control the display on the map of the Underwater Objects features.

- Underwater Object Limit** : Selects the max depth value to display Underwater Objects. If value is set to 0FT, the Underwater Objects are not shown on the charts. Menu options are greyed out. If value is more than 0FT (i.e. 10FT), in the Range from 0FT to the selected value the Underwater Objects are displayed according to their setting below. The default setting is 10FT.
- Rocks** : Sets Off/Icon/Icon+Depth* the displaying of the Rocks. The default setting is Icon.
- Obstructions** : Sets Off/Icon/Icon+Depth* the displaying of the Obstructions. The default setting is Icon.
- Diffusers** : Sets Off/Icon/Icon+Depth* the displaying of Diffusers. The default setting is Icon.
- Wrecks** : Sets Off/Icon/Icon+Depth* the displaying of Wrecks. The default setting is Icon.

NOTE(*)

Choose the options: OFF (the object is not visible independently of the selected "Underwater Object Depth Value"); ICON (the object icon is visible without tags, in the range selected from "Underwater Object Depth Value" option); ICON+DEPTH (the object icon and tag is visible, in the range selected from "Underwater Object Depth Value" option).

12.1 CUSTOMIZING CHART SETTINGS

The GPS Chart Plotter also allows you to customize items shown on the chart (discussed in above sections) instead of using a pre-defined table discussed in Par. 12.0.4 Display Mode.

1. Press **[MENU]**. Move the ShuttlePoint knob to highlight **SETUP MENU** and press **[ENT]**.
2. Move the ShuttlePoint knob to highlight **MAP CONFIGURATIONS** and press **[ENT]** or move the ShuttlePoint knob to the right.

3. Move the ShuttlePoint knob up or down to select the desired item within the groups Marine Settings, Depth Settings, Land Settings, Chart Settings or Underwater Settings and press **[ENT]**. See the above sections for details on selections.

12.2 NAVIGATION PAGE

This page is useful to show information when heading to a destination, following a compass heading or navigating to a Mark or a Route. The default page is shown with a Compass Rose, however this can be customized to show a Compass Tape.

1. To change to show the Compass Tape, select the Chart page, press **[MENU]**. Move the ShuttlePoint knob to highlight **SETUP MENU** and press **[ENT]**.
2. Move the ShuttlePoint knob to highlight **GENERAL SETUP** and press **[ENT]** or move the ShuttlePoint knob to the right.
3. Move the ShuttlePoint knob to highlight **WINDOW SETUP** and press **[ENT]** and press **[ENT]** or move the ShuttlePoint knob to the right.
4. Move the ShuttlePoint knob to highlight **NAVIGATION PAGE** and press **[ENT]** and press **[ENT]** or move the ShuttlePoint knob to the right.
5. Move the ShuttlePoint up or down to select **COMPASS TAPE** and press **[ENT]**.
6. Press **[CLR]** or move the ShuttlePoint knob to the right until the Chart page is shown.

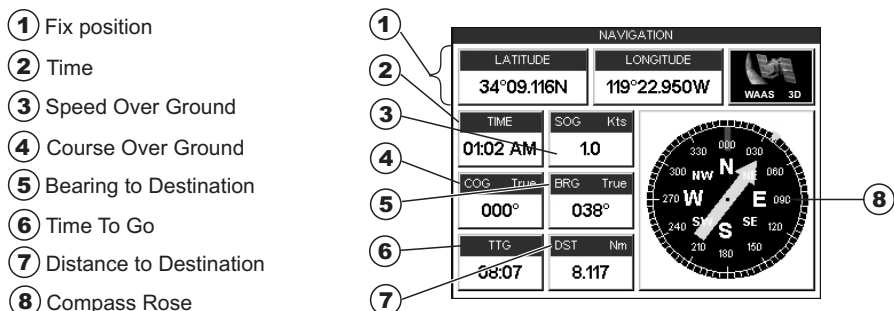

Figure 12.2 - Navigation page with Compass Rose

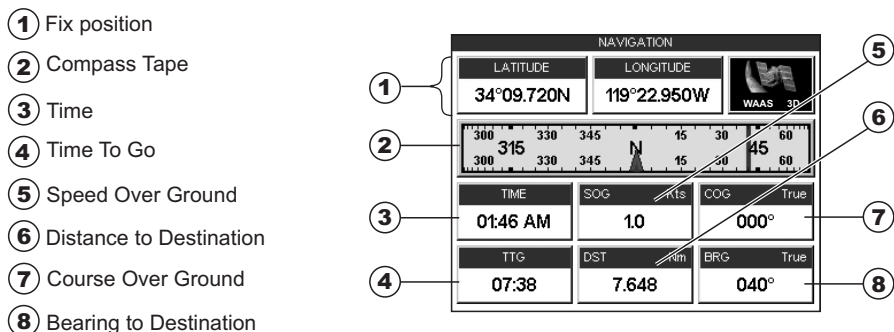

Figure 12.2a - Navigation page with Compass Tape

NOTE

The Compass Rose/Tape gives priority to the compass (Flux Gate or Gyro Compass) data if received. If no data is received from the compass, the Compass Rose/Tape uses the COG value from the GPS.

12.3 HIGHWAY PAGE

Shows a 3D view of the vessel travelling through the water when Navigating to a destination point, Mark or following a Route. Press **[ZOOM IN]** or **[ZOOM OUT]** to change the highway scale.

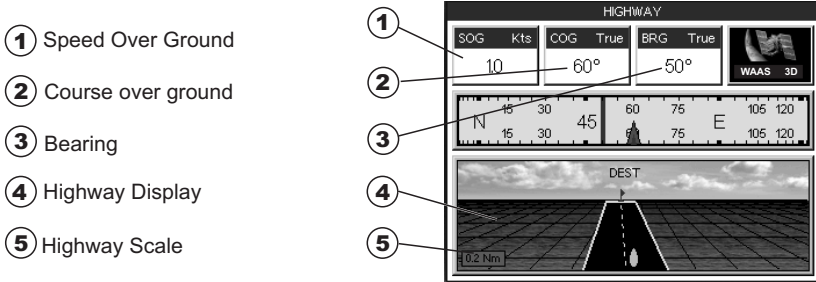

Figure 12.3 - Highway page

12.4 CELESTIAL PAGE

The Celestial page contains Tide information critical for safe navigation. This page is also useful for boaters that are concerned about the height of the water under a bridge or by fisherman that wish to know the tide and moon phase of a specific date.

Changing date

1. Press **[ENT]** and a popup window will be shown.
2. Moving the ShuttlePoint knob up or down changes the digits and left and right selects the month, day and year.
3. Press **[CLR]** to exit and view the information.

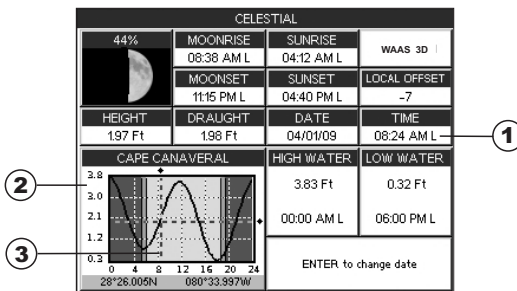

Figure 12.4 - Celestial page

Refer to the image above. The time (1) displayed corresponds to the location of the cross-hair cursor (3) in the Tide Graph (2). Moving the ShuttlePoint knob to the left or right changes the time, moving the ShuttlePoint knob up or down selects the Tide height and draught (draft) on the Tide Graph.

NOTE

The **draught** window shows the height of the tide water during a 24hr period of time. For example if the ShuttlePoint knob is pressed up to move the cursor to the top of the Tide Graph this is the High Water Level and if the cursor is moved to the bottom of the Tide Graph the draught will show the Low Water Level.

Example 1

You anchor in 15FT of water (under your keel) at a time of day where the water is the highest (High Water). Let's say the High Water window shows 5FT and the Low Water window shows 1FT this means the water under your vessel over a 24 hour period of time could fall 4FT (High Water - Low Water). With your vessel in 15FT of water and with a maximum water change of 4FT during the day, the worst case situation there will be 11FT of water under your vessel.

12.5 GPS STATUS PAGE

This page is used as a reference to see how well the GPS is receiving satellites.

- ① Ship's Coordinates
- ② Date and Time
- ③ WAAS/GPS Icon
- ④ Vertical Dilution of Precision
Horizontal Dilution of Precision
- ⑤ Tracked, but not used, Satellite
- ⑥ Used Satellite
- ⑦ COG (Course Over Ground)

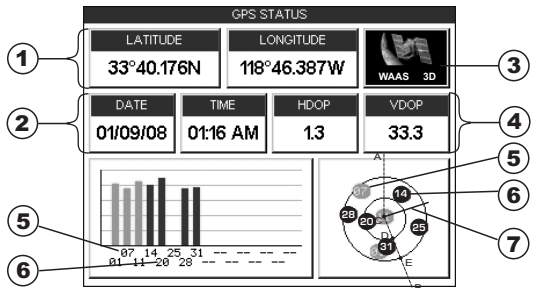

Figure 12.5 - GPS Status page

The WAAS/GPS Icon area may change due to the satellite reception:

ACQUIRING : the GPS is trying to receive a valid position fix.

GPS2D : The GPS is receiving at least 2 valid Satellites

GPS3D : the GPS is receiving at least 3 Satellites.

WAAS 2D/3D : the GPS is receiving a 2D or 3D position and the correction from the WAAS Satellite.

HDOP : Horizontal Dilution of Precision

VDOP : Vertical Dilution of Precision

12.5.0 WAAS/EGNOS Setting

From this page it is possible to disable the WAAS/EGNOS function following this procedure:

1. Press **[MENU]**. Move the ShuttlePoint knob to enter **GPS STATUS** page and press **[ENT]**.
2. Press and hold **[ENT]**. The GPS SETUP menu appears on the screen.
3. Move the ShuttlePoint knob to highlight **DIFF CORRECTION SOURCE** and press **[ENT]**.
4. Move the ShuttlePoint knob to highlight **None** (to disable) and press **[ENT]**.
5. Press **[CLR]** until the menu disappears or an easier method is to move the ShuttlePoint knob to the left until the menu disappears.

12.5.1 GPS Setup Menu

From this page it is possible to activate the GPS Setup menu following this procedure:

1. Press **[MENU]**. Move the ShuttlePoint knob to enter **GPS STATUS** page and press **[ENT]**.
2. Press and hold **[ENT]**. The GPS SETUP menu appears on the screen. See the following table:

Internal GPS	: Enables (On) or disables (Off) the Internal GPS. The default setting is On.
Restart GPS	: Restarts all GPS processes. Once executed, the message "Done" is shown.
Navigation Speed	: Allows setting the Navigation Speed among Low and High. The default setting is High.
Differential Correction Source	: Allows setting what kind of Differential Correction will be used by the GPS between WAAS-EGNOS and none. The default setting is WAAS-EGNOS.

3. Move the ShuttlePoint knob to highlight the preferred item and press **[ENT]**.
4. Press **[CLR]** until the menu disappears or an easier method is to move the ShuttlePoint knob to the left until the menu disappears.

12.6 NMEA DISPLAY PAGE

The GPS Chart Plotter is capable of displaying information in the customizable data windows from external NMEA devices. Depth sounder, Speed Log with temp, Wind speed and direction, Flux gate compass, and GPS information can be shown in any of the boxes. The default NMEA Display shows 3 windows. When going to a destination, this screen is useful to navigate as to get to the destination keep the Course Over Ground (COG) and Bearing (BRG) figures the same.

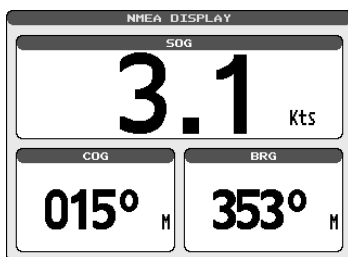

Figure 12.6 - NMEA Display page

The NMEA sentences read from external devices are: BWC, DSC, DSE, GGA, GLL, GSA, GSV, HDG, HDM, HDT, RMC, VHW, VTG, DPT, DBT, MTW, VWR, VWT, TLL, WPL, RTE.

CHANGING the NMEA PAGE Windows

1. On the CP180/CP180i, press **[MENU]**. Move the ShuttlePoint knob to highlight **NMEA DISPLAY** and press **[ENT]**.

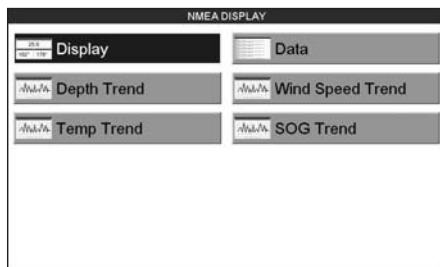

Figure 12.6a - NMEA Display menu on CP300/CP300i

2. The CP300/CP300i can use step 1, and from the factory the right most Soft Key is programmed for direct access. Press this key two times to show the NMEA Display page.
Move the ShuttlePoint knob to highlight **DISPLAY** and press **[ENT]**.
3. To change the 5 different pages move the ShuttlePoint knob to the left or right.

12.7 NMEA DATA PAGE

The NMEA Data page is very useful to see if a External device (example: Depth Sounder) is transmitting NMEA sentences to the GPS Chart Plotter. This page can also be used to see if the GPS Chart Plotter NMEA output is being loaded down by a external NMEA device the GPS Chart Plotter is connected to.

Scenario: VHF Radio connected but the Radio is not receiving a GPS Position.
Usually the VHF Radio will be connected to the Green and Brown wires.

To check to see if the GPS Chart Plotter is transmitting the sentences:

1. Press **[MENU]**. Move the ShuttlePoint knob to highlight **NMEA DISPLAY** and press **[ENT]**.

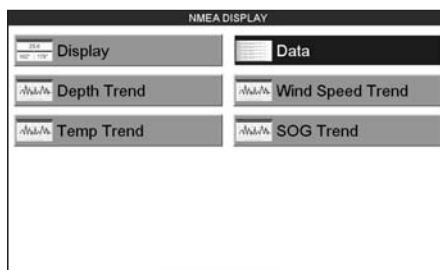

Figure 12.7 - NMEA Display menu on CP300/CP300i

2. Move the ShuttlePoint knob to highlight **DATA** and press **[ENT]**.
3. Connect the BLUE Wire on the GPS Chart Plotter to the junction of the Brown wire and the VHF wire. The display should look similar to the picture below.

```

NMEA DATA
#IIRMC,002558,A,3407.643,N,07702.028,W,003.2,000.0
,190404,9,3,M#61
#PCMPN,0,1,,,,,,#6D
#IIGLL,3407.643,N,07702.028,W,002558,A#2C
#IIUTG,000.0,T,009.3,M,003.2,N,005.9,K#5E
#IIXTE,R,R,,,,#65
#IIRMB,R,,,,,,U#66
#IIRMC,002559,A,3407.644,N,07702.028,W,003.2,000.0
,190404,9,3,M#67
#IIRMB,R,,,,,,U#66
#IIRMC,002556,A,3407.641,N,07702.028,W,003.2,000.0
,190404,9,3,M#6D
#PCMPN,0,1,,,,,,#6D
#IIAPB,R,R,,,,,,#53
#IIGLL,3407.642,N,07702.028,W,002557,A#22
#IIUTG,000.0,T,009.3,M,003.2,N,005.9,K#5E
#IIXTE,R,R,,,,#65

ZOOM IN TO CHANGE PORT      Port: UHF

```

Figure 12.7a - NMEA Data page

4. Press **[ENT]** to freeze the data on the display so it is easy to read and understand.
5. Press **[ENT]** again to receive data again.
6. View data from a device connected to another data port, press the **[ZOOM IN]**.

12.8 NMEA TREND PAGES

When the GPS Chart Plotter is connected to the Optional FF525 (or FF520) 50/200kHz BLACK BOX FISH FINDER or a Digital Depth Sounder, Wind Speed/Direction, Speed Log with Temp with NMEA output the GPS Chart Plotter is capable of show Trends in the data from the device.

To select a NMEA Trend page:

1. Press **[MENU]**. Move the ShuttlePoint knob to highlight **NMEA DISPLAY** and press **[ENT]**.



Figure 12.8 - NMEA Display menu on CP300/CP300i

2. Move the ShuttlePoint knob to select **DEPTH TREND**, **WIND SPEED TREND**, **TEMP TREND** or **SOG TREND** and press **[ENT]**.

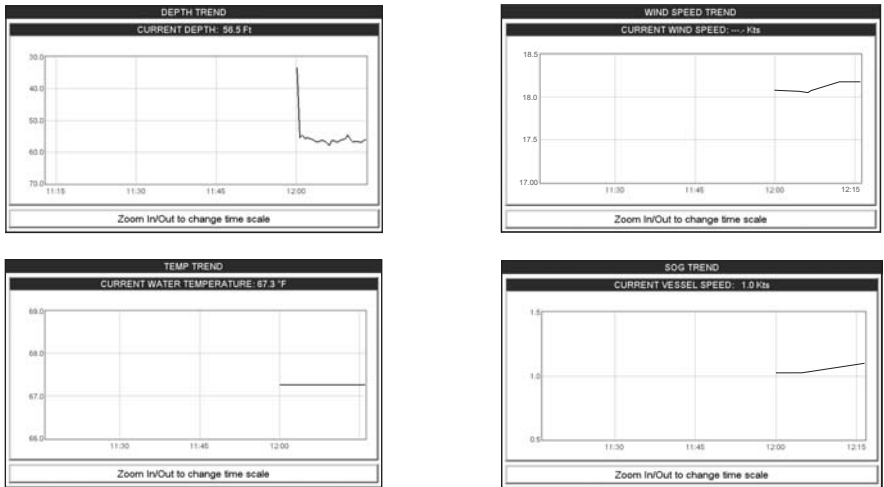

Figure 12.8a - NMEA Trend pages on CP300/CP300i

12.9 VHF DIGITAL SELECTIVE CALLING

Digital Selective Calling is a semi-automated method of establishing a VHF radio call. DSC had also been designated as part of the Global Maritime Distress and Safety System (GMDSS).

This new system allow mariners to instantly send a distress call with GPS position (when connected to the transceiver) to the US Coast Guard and other vessels within range of the transmission. DSC will also allow mariners to initiate POSITION Request, POSITION Send calls to or from another vessel equipped with a DSC transceiver.

STANDARD HORIZON VHF Marine Radios with Digital Selective Calling are able to be interfaced with the GPS Chart Plotter which feeds GPS data to the VHF and listens for DSC calls from the VHF. By connecting a few wires between the STANDARD HORIZON VHF and the GPS Chart Plotter it will receive:

1. a vessel that has transmitted a DSC Distress call
2. a vessel that has transmitted a DSC Position Send Call
3. The position of a vessel that transmitted a DSC Position Request Call

12.9.0 Interfacing

To take advantage of these functions the GPS Chart Plotter must be interfaced (wired) to a STANDARD HORIZON or compatible DSC VHF.

VHF Wires	GPS chartplotter	Description
Blue	Brown	Brown wire (GPS chartplotter) outputs data to VHF
Gray	Blue	Gray wire (VHF) outputs DSC data to GPS chartplotter
Green	Green	Green is data common ground

Figure12.9.0 - Interfacing to VHF Radio

For additional information refer to Par. 2.4 Connections.

12.9.1 DSC Distress Call

During a Distress situation, a vessel that is equipped with a DSC VHF and connected to a GPS, has the capability to transmit a DSC Distress Call with GPS Position.

When the STANDARD HORIZON VHF receives a DSC Distress Call, DSC/Position information of the vessel in Distress is transferred to the GPS Chart Plotter. The GPS Chart Plotter Logs the Distress call into the **DSC DISTRESS LOG** and also prompts the user to see the location of the Vessel in Distress and also allows for easy navigation to the vessel.

12.9.2 Position Request

STANDARD HORIZON VHF radios can transmit a DSC call to other equipped Vessels with a DSC VHF or request this radio transmit the GPS position. When this position is received the STANDARD HORIZON VHF radio sends the information to the GPS Chart Plotter which displays the GPS position of the vessel on the Chart page. This is a great feature for anyone wanting to know the position of another vessel for example you buddy that is catching fish, or finding the location of a person you are cruising with.



13. ADVANCED SETTINGS

The Advanced Setup menu allows customization of many GPS functions, Alarms and NMEA interfacing.

1. Press **[MENU]**. Move the ShuttlePoint knob to highlight **SETUP MENU** and press **[ENT]**.
2. Move the ShuttlePoint knob to highlight **ADVANCED SETUP** and press **[ENT]** or move the ShuttlePoint knob to the right.

While in this menu you will see many selections which are described in the next sections.

13.0 INPUT/OUTPUT (NMEA)

The CP180 has 2 NMEA inputs and 3 NMEA outputs, while the CP180i has 1 NMEA inputs and 2 NMEA outputs. The CP300 has 4 NMEA inputs and 5 NMEA outputs, while the CP300i has 3 NMEA inputs and 4 NMEA outputs.

These Ports may be set up to receive and output the following.

- NMEA0183 - NMEA devices set to 4800 Baud (default setting)
- FF525 (or FF520) 50/200kHz BLACK BOX FISH FINDER - refer to Fish Finder Owner's Manual
- C-Com - C-Weather refer to Section 15
- Radar - SI-TEX optional Radar refer to Radar Owner's Manual
- AIS 38400 - AIS Receiver, refer to Section 14
- MOBILARM - Mobil-arm receiver, refer to Section 16
- Disabled - allow the port to be disabled.

NOTE

When a Port is configured, both the Input and Output have the same setting. Port1 is set to Radar, both the Input and Output wires are set to SI-TEX proprietary Radar sentences. This means other devices should not be connected to the Input or Output wires.

13.1 NAVIGATE

The Navigate menu allows customization of the Coordinate System (Loran TD's), Map Datum, Map Orientation Resolution (angle the vessel has to change before the chart is redrawn) and Static Navigation. See the following table

Coordinate System	: Selections are: a. TD: Time Difference, based on Loran (see the following Par. 13.1.0) b. UTM: Universal Transverse Mercator Grid c. ddd mm.mmm: Degrees Minutes and Thousands of Minutes d. ddd mm.mm: Degrees Minutes and Hundredths of Minutes e. ddd mm.ss: Degrees Minutes and Seconds (default)
Map Datum	: Allows selection of Map Datums. The default Datum is WGS84 as C-MAP By JEPPESEN cartography has been compiled using the WGS84 Datum. A datum is a mathematical model of the Earth which approximates the shape of the Earth, and enables calculations such as position and area to be carried out in a consistent and accurate manner.
Map Orientation Resolution:	Sets the angle the vessel has to change before the chart is redrawn. The default setting is 30 degrees. Example: if the vessel is heading 000T at a speed of 25 Knots, the display will redraw: a. In Home mode the GPS Chart Plotter centers the location of the vessel in the center of the display. To keep the vessel in the center of the display the GPS Chart Plotter will occasionally redraw.

b. If the vessel changes course greater than 330T or more than 30T the chart will be redrawn.

Static Navigation : Sets up a threshold for the speed. When the speed received from the positioning device is under that threshold, the GPS Chart Plotter displays zero. The default setting is 0.9 Kts.

13.1.0 Loran TD

The Loran TD selection allows the GPS Chart Plotter to be set up so the user can enter in LORAN TD's directly into the GPS Chart Plotter. After the TD's have been entered, and the user changes to ddd mm.sss (Degrees Minutes and Seconds) the TD's will be converted to Lat / Lon coordinates.

To use the TD Coordinate System the user must setup the Chain and Pair information of the TD's. If you do not know this information, refer to paper charts that show the Chain and Pair information.

ASF1/2 : **Additional Secondary phase Factor (TD Coordinate System)**
Correction to TD1/2 values which can be inserted by the user to take in account the additional signal propagation delay over a mixed land/seawater path compared to an all-seawater path. Normally the user does not enter a ASF value. However for experienced users this function allows entering of signal delay values to fine adjust the calculated position. The user should enter delay values to fine adjust the position calculated.

Alter : **Alternate Solution (TD Coordinate System)**
Parameter selected by the user that is applied in the conversion of geographical coordinates Lat/Lon to TD values. To be used if the position displayed is roughly not correct.

13.2 COMPASS

The GPS Chart Plotter computes compass direction from the constellation of GPS Satellites. For the GPS Chart Plotter to compute direction the vessel must be moving through the water. This menu allows the GPS Chart Plotter to customize the following selections:

Bearings : Selects between True and Magnetic. When Magnetic bearings is enabled, the GPS Chart Plotter applies the selected Magnetic Variation (Auto or Manual, see next paragraph) to compute Magnetic bearing.

Variation : Allows the user to select Auto or Manual. When Auto mode is selected the GPS Chart Plotter computes the offset by the current GPS fixed location. Manual mode allows the user to enter in a magnetic variation that is applied in the True conversion.

Calibration : This function allows a user to enter in the offset for areas that the vessel may cruise instead of entering in a manual offset for one location. This offset is useful for cruising vessels or vessels that travel internationally often.

N	N/E	E	S/E	S	S/W	W	N/W
+01°	+02°	+00°	-01°	-01°	+01°	+03°	+02°

Figure 13.2 - Compass Table

13.3 ALARMS

This menu is used to select and setup audible and visual Alarms. Available alarms are Arrival, XTE, Depth, Anchor and Grounding Alarm.

Arrival Alarm : Alerts when the vessel is approaching a single destination point or when arriving at a leg in a Route. Available selections: 0.00 to 9.99NM.

XTE Alarm : Alerts when the vessel is deviating from a defined course. Available selections: 0.00 to 9.99NM.

Depth Alarm : Alerts when the received depth Value from the optional FF525 (or FF520) 50/200kHz BLACK BOX FISH FINDER or Depth Finder inputting NMEA data into the GPS Chart Plotter is lower than the selected value. Available selections: 0000 to 3000FT.

Anchor Alarm : Alerts when the ships moves off a selected locations by a selected distance. Available selections: 0.00 to 9.99NM.

Audible Alarm : Enables or disables the alarm beep.

Grounding Alarm : This function looks ahead of the vessels heading to see if a potential danger exists. When the Grounding Alarm is enabled the GPS Chart Plotter will draw a triangle in front of the vessel on the Chart page showing the area that is being searched as shown below. The depth and range (distance) of the area the GPS Chart Plotter looks ahead for a shallow area can be set using this function.

The following warning appears when the Grounding Alarm is enabled:

NOTES

The Grounding Alarm function only operates with the new NT*/MAX C-CARDS. It also affects the speed of the redraw of the screen. If this function is not used it may be disabled.

When any of the objects checked are found for the first time, the GPS Chart Plotter shows a pop up window to alert the user of the possible danger. The name of each new dangerous object found is reported in the warning window. In the Grounding Alarm Report page the relative item has a tick marker next to it, to identify the dangerous object currently detected. If in the next search cycle the same objects are found again, the alarm window will not be shown. Instead, if in the next searches the objects found before are no longer detected, their relevant item in the Grounding Alarm Report page is cleared (note that in this case, if the same object type is found again later, the Alarm will be shown). The GPS Chart Plotter shows an icon on the charts that identifies when a Grounding Alarm is detected.

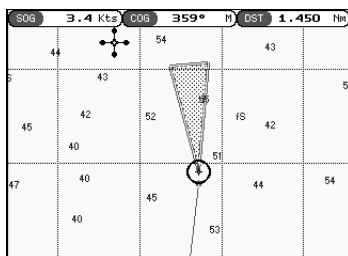

Figure 13.3 - Grounding Alarm

- Ground Alarm Range** : Allows setting the distance of the grounding alarm zone. Available selections are 0.25, 0.5 and 1.0NM. The default selection is 0.25NM. When a depth or a object is found in the scanned zone area a marker is printed in the Grounding Alarm Report Page to identify which dangerous objects have been currently detected.
- Grounding Alarm Report** : Displays a report of dangerous objects found.

13.4 SIMULATION

The built-in Simulator function allows you to become proficient in the use of the GPS Chart Plotter.

Simulation Mode : Three selections:
a. Off - turn the simulation mode off
b. On - enable the simulator mode, where the speed and course are adjusted by entering in values in the Course and Speed selection discussed later in this table.
c. Route - this selection allows you to navigate to a saved route.

Course : To start the simulator you can insert the Course value.

Speed : To start the simulator you can insert the Speed value.

Date : To start the simulator you can insert the date.

Time	: To start the simulator you can insert the time.
Cursor Control	: Enables (On)/disables (Off) the cursor control.
Demo Mode	: In Demo mode the GPS Chart Plotter automatically places a Destination point on the Chart page and simulates navigation to the point. Also, the active page changes automatically every 10 seconds. The pages are shown in the following order: Start-up screen, GPS Status page, Chart/Compass tape page, Chart/Fish Finder page, Fish Finder Full page, Radar page, Navigation page, Highway Page, Celestial page, NMEA Display page. Once the Demo mode is enabled, pressing any key it is possible to temporarily exit and returns to GPS Chart Plotter normal operation, but if you do not touch any key for 30 seconds Demo mode re-starts.

13.4.0 Navigating a Route in Simulation mode

This selection allows you to navigate to a saved Route to see how data windows on the Chart page and how the Navigation and Highway pages operate.

1. Create a Route. Refer to Par. 9.0 Route.
2. Press **[MENU]**, move the ShuttlePoint knob to highlight **SETUP MENU** and press **[ENT]**.
3. Move the ShuttlePoint knob down to highlight **ADVANCED SETUP**, then press **[ENT]**.
4. Move the ShuttlePoint knob to highlight **SIMULATION** and press **[ENT]**.
5. Move the ShuttlePoint knob to highlight **SIMULATION MODE** and press **[ENT]** to show a popup window.
6. Move the ShuttlePoint knob to highlight **ROUTE** and press **[ENT]** which will show a popup window with the Route(s) that are stored in the GPS Chart Plotter's memory.
7. Highlight the desired Route and press **[ENT]**.
8. Move the ShuttlePoint knob to highlight **SPEED** and press **[ENT]**.
9. Enter in the speed you want to vessel to travel at in simulation mode, by moving the ShuttlePoint knob left or right to select a number and up or down to change a number.
10. When the speed is adjusted, press **[ENT]**.
11. Press **[CLR]** multiple times until the Chart page is shown.

13.5 DSC POLLING

This menu is used to enable or disable features related to the DSC function.

Auto Position	: Selects between Manual or Auto. See also the Par. 12.8.1. When Auto Position item is set to Manual and receiving the Position Request, the Position Request popup window is not displayed and the cursor does not move to the position of the received Position Request data point. Otherwise when Auto Position item is set to Auto , the GPS chart plotter works as follows: <ol style="list-style-type: none"> 1 : when receiving the Position Request, the Position Request popup window is displayed; 2 : when selecting VIEW ON CHART, the position is indicated on the chart marked with "P". The cursor is moved to the point "P" and shows the point in the center of the screen; 3 : when moving the cursor from "P", the location can be confirmed. At this time, the same MMSI Position Request data that were received before are remaining and displayed.
Auto Info	: Enables or disables the Auto Info. This selection is available only when Auto Position is set to Manual. If Auto Info is set to On, when receiving the Position Request it is possible to center the cursor over the top of the Position Request icon and show the Position Request popup window

14. AIS

AIS is an Automatic Identification System. It has been introduced to improve the safety of navigation by assisting in the efficient operation of ship-to-ship location reporting and VTS applications. The system should enable operators to obtain information from the ship automatically, requiring a minimum of involvement of ship's personnel, and should have a high level of availability. AIS transponders installed on IMO vessels use VHF frequencies to:

- Transmit details of their own vessel
- Receive details from other vessels or navigation aids within VHF range.

Information being transmitted from vessels over 300 tons that, due to recent worldwide legislation, are required to fit Class "A" AIS transponders.

Connecting to the GPS Chart Plotter an AIS receiver (please contact your local dealer), will display vessels with AIS transponder within VHF range on screen giving the skipper or navigator a visual interpretation of the data of nearby vessels. This improves safety, and specifically for collision avoidance reasons.

14.0 AIS SYSTEM DEFINITIONS

- **Target:** It is a vessel equipped with AIS. Information about the targets is being received by AIS Receiver and displayed on the screen.
- **CPA:** Closest Point of Approach is the closest distance that will be achieved between your vessel and the tracked target, based on your vessel's speed and direction and the target's speed and direction.
- **CPA Limit:** This is the distance from your vessel that a target may reach before a target is deemed a threat.
- **CPA Alarm:** Occurs if CPA is less or equal to CPA Limit. This test is done for active targets only.
- **TCPA:** Time to closest Point of Approach is the time remaining until the CPA will occur.
- **TCPA Limit:** This is the time remaining before the CPA is reached.
- **TCPA Alarm:** Occurs if TCPA is less or equal to TCPA Limit. This test is done for active targets only and if CPA value is less or equal to CPA Limit.
- **Radio Call Sign:** International call sign assigned to vessel, often used on voice radio.
- **Name:** Name of ship, 20 characters.
- **MMSI:** Maritime Mobile Service Identity.
- **MMSI number:** A unique 9 digit number that is assigned to a DSC radio station. It primarily registers the boat information in the U.S. Coast Guard's national distress database for use in emergency situations.
- **Active Target:** Target located within the Activation Range. Active target is represented by oriented triangle with COG and Heading vectors. Rate of turn may also be displayed.
- **Dangerous Target:** Target detected by CPA or TCPA Alarm. Dangerous target is Active Target by definition. For better visibility Dangerous Target symbol is flashing.
- **Sleeping Target:** Target located outside the Activation Range. Sleeping target is represented by a small oriented triangle.
- **Lost Target:** When the AIS info is not received from that vessel for 3.5 minutes. The presentation will be a flashing black triangle with a cross through.

- **Activation Range:** Range around your boat where targets become active. AIS target become active within this range. Activation Range should be greater than CPA Limit by definition.

NOTE

A target is removed from the screen if data is not received for 10 minutes.
 The maximum number of tracked targets is 200.
 Depending on the scale the presentation of the targets change to remove clutter on the screen. This information is updated every 3 seconds to 6 minutes depending on speed and rate of turn, enabling the track of the vessels in range to be plotted.





TARGET STATUS	DESCRIPTION	SYMBOL
ACTIVE TARGET	Target located within the Activation Range.	
DANGEROUS TARGET	Target detected by CPA or TCPA Alarm. Dangerous Target is Active Target by definition.	 Flashing
SLEEPING TARGET	Target located outside the Activation Range.	
LOST TARGET	Ais info is not received from that vessel for 3.5 minutes.	

Figure 14.0 - AIS Symbols

14.1 AIS MENU

To configure the GPS Chart Plotter to receive AIS data, follow the procedure:

1. Press **[MENU]**. Move the ShuttlePoint knob to highlight **SETUP MENU** and press **[ENT]**.
2. Move the ShuttlePoint knob to highlight **AIS SETUP** and press **[ENT]** or move the ShuttlePoint knob to the right. The new AIS menu appears on the screen. The available functions are described in the following table.

Display	: Turns the display of AIS Targets overlay on the cartography On or Off. The default setting is On.
Activation Range	: Defines the range from the fix within which the AIS Target becomes active. The values allowed are from 0.1 to 20NM. The default setting is 5NM.
CPA Alarm	: Turns On or Off the alarm. The default setting is On.
CPA Limit	: The values allowed are from 0.1 to 10NM. The default setting is 0.5NM.
TCPA Alarm	: Turns On or Off the alarm. The default setting is On.
TCPA Limit	: The values allowed are from 1 to 30 Min. The default setting is 10 Min.

14.2 TO SET THE CHART PLOTTER FOR RECEIVING AIS

Make sure that the AIS receiver is properly connected to the GPS Chart Plotter (refer to Par. 2.4). The GPS Chart Plotter reads the AIS NMEA message VMD, type 1, 2, 3 and 5. Select the used serial port and transmission speed by following the procedure:

1. Press **[MENU]**. Move the ShuttlePoint knob to highlight **SETUP MENU** and press **[ENT]**.
2. Move the ShuttlePoint knob to highlight **ADVANCED SETUP** and press **[ENT]** or move the ShuttlePoint knob to the right.
3. Move the ShuttlePoint knob to highlight **IN/OUT CONNECTIONS** and press **[ENT]** or move the ShuttlePoint knob to the right.
4. Move the ShuttlePoint knob to highlight **PORTn** and press **[ENT]** or move the ShuttlePoint knob to the right.
5. Move the ShuttlePoint knob to highlight **AIS 38400** and press **[ENT]** or move the ShuttlePoint knob to the right.

Where:

n = FOR CP180/CP180i Port1/Port2*/Port3
FOR CP300/CP300i Port1/Port2*/Port3/Port4/Port5

NOTE*

For CP180i and CP300i there is not the selection for the Port2.

14.3 QUICK INFO ON AIS TARGET

By placing the cursor over a AIS Target icon using the ShuttlePoint knob, the following information is displayed:

- Vessel Name
- MMSI number
- Radio Call Sign
- SOG
- COG
- CPA and TCPA values

NOTE

The selected AIS Target icon is surrounded by a square frame when user places the cursor over the icon.

14.4 AIS LIST

It is possible to show the AIS List page that show basic information of the Target ship with the ability to select a Target ship and locate it on the chart.

Follow the procedure:

1. Press **[MENU]**. Move the ShuttlePoint knob to highlight **USER POINTS** and press **[ENT]**.
2. Move the ShuttlePoint knob to highlight **AIS LIST** and press **[ENT]**.

AIS LIST				
NAME CALL SIGN	MMSI	IMO NUMBER	SOG Kts COG T	CPA Nm TCPA
SIMUL0 SIMUL0	100000000	100000003	18 236°	3.18 --:--:--
SIMUL7 SIMUL7	100000007	100000010	10 38°	4.18 --:--:--
SIMUL1 SIMUL1	100000001	100000004	2.3 63°	--:-- --:--:--
SIMUL2 SIMUL2	100000002	100000005	16 186°	--:-- --:--:--
SIMUL3 SIMUL3	100000003	100000006	10 242°	--:-- --:--:--
SIMUL4 SIMUL4	100000004	100000007	3.0 14°	--:-- --:--:--

ENT to show the target on chart

Figure 14.4 - AIS List page

3. Move the ShuttlePoint knob up or down to select the Target and scroll the page up or down. Press **[ENTER]** exits the page and shows the Target ship on the Chart page along with the current position of the GPS Chart Plotter.

15. C-WEATHER SERVICE

C-Weather is a **free** service available on the CP180/CP180i and CP300/CP300i. C-Weather service gives excellent coverage for the whole World. Weather forecasts are based on data received from the leading meteorological centers. This data is processed by Jeppesen server and made available via TCPIP connection. By using C-Map BY JEPPESEN optional PC-Planner Windows Application the data can be loaded into a User C-CARD to be transferred to the GPS Chart Plotter (see Par. 15.0.1). The Service of downloading the data via C-COM is available on the Mediterranean area only (see Par. 15.0.0).

Features: 5-day weather forecast updated every 6 hours; coverage of 180x180 NM with information frequency of 0.5° Lat/Lon; wind direction and strength; wave height and direction; ground temperature; level of humidity; visibility in miles.









Data Type	Display
WIND (Speed & Dir)	- 0 
WAVE Height & Dir	- 1 
TEMPERATURE	18°
HUMIDITY (%)	30
VISIBILITY	20
WEATHER TYPE: Sun	
WEATHER TYPE: Rain	
WEATHER TYPE: Fog	
WEATHER TYPE: Snow	
WEATHER TYPE: Clouds	
WEATHER TYPE: Partly Cloudy	
WEATHER TYPE: Thunderstorm	

Figure 15 - Weather data package

15.0 C-WEATHER SERVICE MENU

To select the menu:

1. Press **[MENU]**. Move the ShuttlePoint knob to highlight **SETUP MENU** and press **[ENT]**.
2. Move the ShuttlePoint knob to highlight **C-WEATHER SERVICE** and press **[ENT]** or move the ShuttlePoint knob to the right.

The C-Weather menu is shown on the screen, the items are described in the following paragraphs.

15.0.0 Download

Allows to connect the software to the weather server and to download weather data directly via C-COM.

Select Country To Call : Allows the selection of the country to call. The whole telephone number set is automatically updated after every download.

SIM Pin : Allows inserting of the Pin of the SIM.

Download Area : Allows the weather download: a squared grey area, where the weather data will be downloaded, is centered on cursor position. See the following picture.

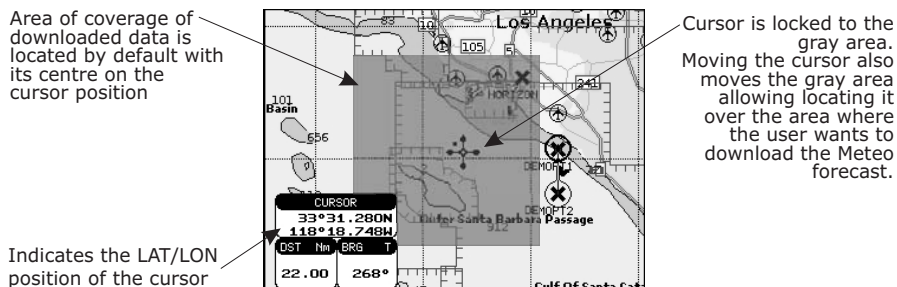

Figure 15.0.0 - Example of Download Area on CP180/CP180i

Press [LOAD] (or [ENT] for CP80/CP180i) to activate the C-Weather Download: the whole data package (see the previous "Weather data package" table) are downloaded. **[STOP] (or [CLR] for CP180/CP180i)** allows to interrupt the data download. At the end of the operation press **[EXIT] (or [CLR] for CP180/CP180i)** to close the window.

15.0.1 Copy From User C-CARD

Allows the whole data package C-Weather loading from the User C-CARD.

15.0.2 Weather Forecast

Allows selecting the Layer of specific weather data to be displayed on the screen and to change date and time of the forecast preview. The following functions are available:

- **Panning:** default usage of the cursor key is the normal panning function.
- **Zoom in/out:** zoom in/out functions are allowed as usual by using **[ZOOM IN]/[ZOOM OUT]**.
- **Set of date and time:** **[DATE]** (or **[GOTO]** for CP180/CP180i) to modify date and time values.
- **Layer selection:** **[LAYER]** (or **[MENU]** for CP180/CP180i) to cycle of the weather layers.
- **Exit:** **[EXIT]** (or **[CLR]** for CP180/CP180i) to close the weather prediction page.

15.0.3 Real Time View

The following selections are available:

- **Real Time View On:** the data is shown (the area of the download) at the current date and time (received from the GPS).
- **Real Time View Off:** the Weather data is not displayed.

The layer displayed is the one selected into the previous menu item.

15.0.4 Type of Data

Allows selecting the type of data, refer to the table in the Figure 15.

16. MOBILARM

The MOBILARM is an automated crew monitoring system dedicated to monitoring onboard crew by maintaining a constant link between the crew member and the boat. When a man overboard event happens, an automatic alarm is sounded, and the vessels position is shown on the Standard Horizon GPS Chart Plotter.

16.0 MOBILARM-GPS CHART PLOTTER CONNECTION

Connect the MOBILARM system to one of the Ports on the Standard Horizon GPS Chart Plotter. Refer to Par. 2.4.0 "Connection Table" for CP180/CP180i, Par. 2.4.1 "Connection Table" for CP300/CP300i and MOBILARM Owner's Manuals for connections.

Connection Example

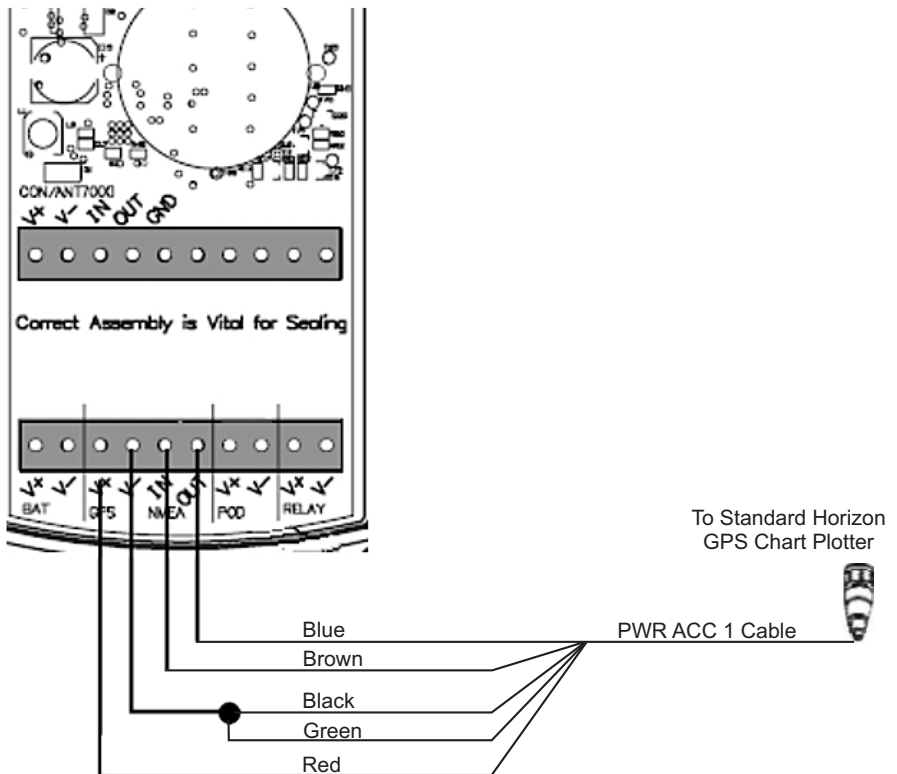

Figure 16.0 - Connection Example

Port 1 Example

Chart Plotter	MOBILARM
Blue	NMEA Out
Brown	NMEA In
Red	GPS V+
Black	GPS V-

NOTE

Refer to the Figure 16.0, the Blue and Brown wires are from Port 1. If these wires are being used to connect to another NMEA device, choose another wire pair and configure the port associated with the wires.

16.1 SOFTWARE SETUP

After the Port has been chosen and connected in Par. 16.0, the GPS Chart Plotter must be setup to communicate with the MOBILARM.

Use the steps below to set up the Port the MOBILARM is connected to the GPS Chart Plotter.

1. Select the Chart page.
2. Press **[MENU]**. Move the ShuttlePoint knob to highlight **SETUP MENU** and press **[ENT]**.
3. Move the ShuttlePoint knob to highlight **ADVANCED SETUP** and press **[ENT]** or move the ShuttlePoint knob to the right.
4. Move the ShuttlePoint knob to highlight **IN/OUT CONNECTIONS** and press **[ENT]** or move the ShuttlePoint knob to the right.
5. Move the ShuttlePoint knob to highlight any input port and press **[ENT]** or move the ShuttlePoint knob to the right.
6. Move the ShuttlePoint knob up/down to select **MOBILARM** and press **[ENT]** or move the ShuttlePoint knob to the right. Selecting MOBILARM format, activates the function.
7. Press **[CLR]** or move the ShuttlePoint knob to the left until the Chart page is shown.

The GPS Chart Plotter continuously verifies the communication status with MOBILARM PTX (Personal Transponder) device. When a signal from the PTX is lost for more than one minute, the MOBILARM sends a NMEA message to the GPS Chart Plotter which will produce an alarm and a popup window will be shown on Standard Horizon GPS Chart Plotter.

16.2 MOBILARM STATUS

To confirm the status of the MOBILARM, select the About page:

1. Select the Chart page.
2. Press **[MENU]** two times. Move the ShuttlePoint knob to highlight **About...** and press **[ENT]**.

On the About page you can see the status of the MOBILARM, below are the possible messages.

- a. **Function not Activated** : MOBILARM has not been setup in the I/O Connections menu. Refer to Par. 16.1.
- b. **Not connected/detected** : possible wiring problem, confirm wires are correct connected from the GPS Chart Plotter to the MOBILARM device.
- c. **Connected** : the communication with MOBILARM device is Ok.
- d. **Signal Lost** : the MOBILARM has been connected in the past, however

er no signal is being detected from the MOBILARM. Check wire connections from the GPS Chart Plotter to the MOBILARM.

- e. **No valid GPS position** : the communication with MOBILARM device is Ok, but the GPS position fix is not received from the GPS Chart Plotter.

See the following example of About page:

① MOBILARM status Information

CHARTING OPERATING SYSTEM,
Copyright (C) 2006 - 2008 JEPPESEN Italia S.r.l

Software	XXXXXX	YYYY
NTSL	V7.5.23 R [29/02/2008]	
KERNEL	V1.42.0 R [15/04/2008]	
FILE SYSTEM	V3.21.9 R [15/01/2007]	
BIDS	V1.5.5 R [1/03/2008]	
GPS	Generic	
FF LIBRARY	V1.27.00R [11/02/2008]	
FF MODULE	FF 520	
RADAR LIBRARY	V1.19.00R [20/11/2007]	
RADAR MODULE	Not detected	
C-WEATHER	V1.14.00 R [26/10/2007]	

C-CARD:	M-NA-M632.00 LOS ANGELES and SAN PEDRO BAYS	
User Points	3000	
Routes	50	
Track Points	10000	
Tracks	20	
MOBILARM	Connected	

 by JEPPESEN

MENU for System Update Menu

Figure 16.2 - Example of About page with MOBILARM information on CP300/CP300i

16.3 MOBILARM PTX

A PTX is the Personal Transponder device that is worn by the crew. If a crew member falls in the water the MOBILARM sends a signal to the GPS Chart Plotter which creates and displays a PTX icon on the Chart page.

16.3.0 MOBILARM MOB alert is received

When crew member falls in the water, the MOBILARM sends a signal to the GPS Chart Plotter which creates and displays a PTX MOB icon on the Chart page.



Figure 16.3.0 - The PTX icon

On the GPS Chart Plotter all menus and/or pages are closed and the chart is centered on the PTX MOB received position. A Audible Alarm is heard and a popup warning window appears to notify that a PTX has been received:

TIME	11:47 AM	SOG	1.0	Kts	COS	25°	True	GPS 3D
TTG	---	DST	---	Nm	BRG	---	True	30km

MOBILARM

37°45.499N
122°40.412W

Id	Time
0000002	11:47:39 AM

GOTO LIST

Figure 16.3.0a - Example of PTX warning window on CP300/CP300i

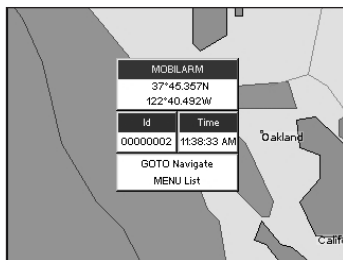

Figure 16.3.0b - Example of PTX warning window on CP180/CP180i

It is possible to Goto (navigate) to the received MOBILARM PTX position (see Par. 16.4.1) or open the MOBILARM Alarm Status List page (see Par. 16.4.2). Selecting Goto or Alarm Status List will mute the Audible Alarm.

NOTE

When the same PTX is received again:

- If the received PTX is not the active one, the user must confirm to navigate to it.
- If the received PTX is the active one, navigation data is updated. The PTX icon appears at the new position and a popup warning window appears.

16.4 PLACING CURSOR ON THE PTX ICON

Moving the ShuttlePoint knob so the cursor is over the PTX icon on the Chart page will show an information window and allow you to Goto the location of the PTX, delete the PTX icon or show the Alarm Status list as shown below.



Figure 16.4 - Example of PTX information window on CP300/CP300i

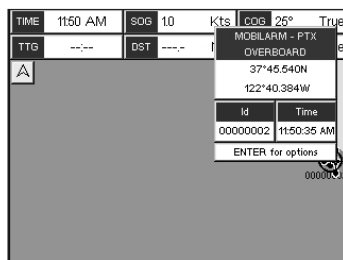

Figure 16.4a - Example of PTX information window on CP180/cp180i

16.4.0 Delete PTX

The Delete PTX function permanently removes the selected PTX from the MOBILARM Alarm Status List and from the Chart page.

Using the ShuttlePoint knob, move the cursor over the PTX icon and then:

ON CP180/CP180i

press **[ENT]**, select **DELETE** using the ShuttlePoint knob and press **[ENT]**. A warning popup window will be shown. Select **YES** and press **[ENT]**.

ON CP300/CP300i

press **[DELETE]** A warning popup window will be shown. Select **YES** and press **[ENT]**.

16.4.1 Goto PTX

When Goto is selected on the GPS Chart Plotter, navigation will start to the PTX icon location. After the GPS Chart Plotter has received a PTX MOB alarm, using the ShuttlePoint knob move the cursor over the PTX to navigate to and then:

ON CP180/CP180i

press **[ENT]**, select **GOTO** using the ShuttlePoint knob and press **[ENT]**.

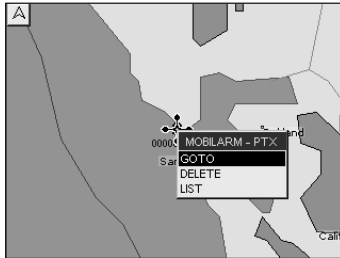

Figure 16.4.1 - Example of Goto PTX on CP180/CP180i

ON CP300/CP300i

two Soft Keys under the display will be shown:

- [Goto]**, when pressed will start navigating to the PTX MOB location
- [List]**, when pressed will show the MOBILARM Alarm Status List page. Refer to Par. 16.4.2 for Alarm Status List.



Figure 16.4.1a - Example of Goto PTX on CP300/CP300i

If the navigation is set to the selected PTX icon, to terminate the navigation:

ON CP180/CP180i

press [ENT], select **STOP GOTO** using the ShuttlePoint knob and press [ENT].

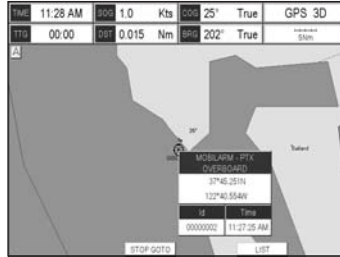

Figure 16.4.1b - Example of Stop Goto PTX on CP180/CP180i

ON CP300/CP300i

press [StopGoto].



Figure 16.4.1c - Example of Stop Goto PTX on CP300/CP300i

16.4.2 The MOBILARM Alarm Status List

The MOBILARM Alarm Status List shows the list of all PTX that the GPS Chart Plotter has received an alarm from. To review the page:

1. Select the Chart page.
2. Press [MENU] to show the Main menu.
3. Move the ShuttlePoint knob to highlight **USER POINTS** and press [ENT].
4. Move the ShuttlePoint knob to highlight **MOBILARM** and press [ENT].

- ① PTX number
- ② Time the PTX alarm was received
- ③ PTX position
- ④ PTX status

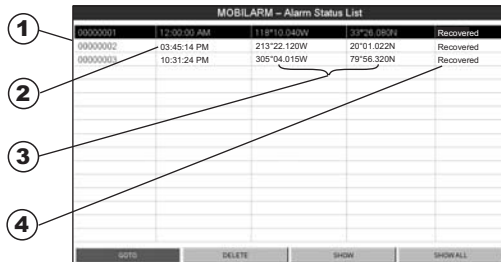

Figure 16.4.2 - Example of MOBILarm PTX List page on CP300/CP300i

This page allows you to:

GOTO	Activates navigation to the selected PTX. Once the navigation has been activated, close all menus/data pages (if open) and center the chart selected PTX.
DELETE	Deletes the selected PTX.
SHOW	Centers the chart on the selected PTX.
SHOW ALL	Selects the best chart scale to see PTX icons on the map at the same time.



17. TROUBLESHOOTING

The GPS Chart Plotter does not turn On. The voltage or the polarity may not be correct. Make sure that the correct voltage (10-35 volt dc) is present. Check also that the polarity is correct.

The GPS Chart Plotter does not get a valid fix. The external WAAS GPS antenna may not be in an open sky position or the antenna cable may not be properly connected. Make sure that no metal obstacle is placed around the antenna acting as a shield for the antenna and disconnect and connect again the antenna cable to the GPS Chart Plotter. If, after 15 minutes, the GPS Chart Plotter does not get the fix, turn it Off and On again.

The GPS Chart Plotter does not turn Off. The GPS Chart Plotter may be in an unpredictable status. If, after pressing **[PWR]** (for at least 3 seconds) the GPS Chart Plotter does not turn Off, turn Off the voltage.

The GPS Chart Plotter screen becomes very dark after a long exposure to direct sunlight. The internal temperature is very high. Control the contrast. Protect the GPS Chart Plotter from direct sunlight.

The GPS Chart Plotter does not respond to any command. The GPS Chart Plotter may be in an unpredictable status. Try to turn Off, and then turn On. If the problem persists, reset the RAM or remove power from the battery.

The location of my fix is not shown correctly on the Chart page. Please report to Jeppesen Marine the Latitude & Longitude of your vessels position, the position where you think your vessels should be and details of the cartography such as "Compilation scale", "Notice to mariners" and "Horizontal datum" (which can be seen by selecting the Chart page, press **[INFO]**, move the ShuttlePoint knob to **Data Source** and press **[ENT]**).

After storing the Chart Plotter over the winter, it takes a long time to receive a fix. This is usually caused by the internal rechargeable memory battery from becoming low which could cause the Internal RAM memory to become corrupted. To solve this issue, perform a RAM clear (refer to Section 18).

NOTE

After performing a RAM Clear all Marks, Routes and tracks will be erased. To back up these points refer to Section 11 for details.

18. TECHNICAL TESTS

18.0 SYSTEM TEST

If you have connected your GPS Chart Plotter according to the instructions, and chosen the proper menu selection for your device, and are still having problems with your GPS Chart Plotter, the extended auto-test should help determine the problem. Make sure the GPS Chart Plotter is turned Off. While pressing and holding any other key, turn the GPS Chart Plotter On. A new menu will appear on the display:

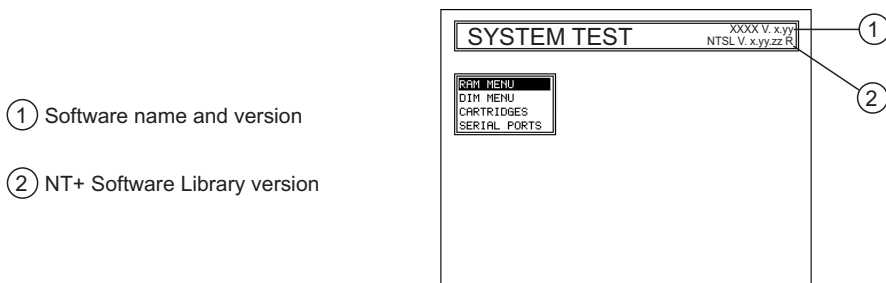

Figure 18.0 - System Test

Use the ShuttlePoint knob to select the desired test. Choose the test, press **[ENT]**. To exit from any submenu press **[CLR]**. To exit from the System Test turn Off the GPS Chart Plotter.

18.0.0 RAM Menu (reset)

This test verifies the integrity of the memories and if desired during this test all the internal memory can be erased and the default setting restored.

RAM Clear

To clear internal memory. If the GPS Chart Plotter exhibits unusual operations, or appears to be malfunctioning, it may be possible to correct the problem by clearing RAM.

This operation will erase all Marks, Routes, stored Track plots and Destinations. It will also return all selections (Input Data Format, Autopilot selection, etc.) to original default values. To confirm clear RAM press **[ENT]** again (but if at this time you do not wish to clear RAM press **[CLR]**).

18.0.1 DIM Menu

To select the desired value for brightness and keypad light.

Contrast

Each time you move the ShuttlePoint knob to right, the screen will decrease brightness, move it to the left to increase brightness.

Backlight

The second option allows to set the backlight. Operates in similar mode as Contrast.

18.0.2 Cartridges

To check the C-CARD and its connector.

Internal Data Base Test

To test the Worldwide Background.

C-CARD Test

To test the C-CARD. There are the possible situations:

1. if there is a C-CARD inserted in the slot and there is not a malfunction, the name of the C-CARD zone and the message "OK" are shown.
2. if there is a C-CARD inserted in the slot, but it is a defective C-CARD, the name of the C-CARD zone and the message "Faulty" are shown.
3. if there is not any C-CARD inserted in the slot, the message "not present" is shown.
4. if there is a User C-CARD inserted in the slot, the message **USER C-CARD** is shown.

C-CARD Connector

Indicates if there is a malfunction in the connector.

18.0.3 Serial Ports

If you are having problems receiving data from the position-finding instrument, this test should help determine the problem.

Change Parameters

To change the parameters of the serial interface. This menu allows to select the **Port** (Signal Source) between PORT 1, PORT 2, PORT 3 (PORT4 and PORT 5 ONLY FOR CP300/CP300i); the **Baud Rate** between 300, 1200, 2400, 4800, 9600, 38400, 115200; the **Data Bits** (Word Length) between 7 or 8, the **Parity** between even, odd or none, the **Stop Bits** between 1 or 2. Default settings are: Port = PORT 2, Baud Rate = 4800, Data Bits = 8, Parity = none, Stop Bits = 1.

Input Data Display

To allow the GPS Chart Plotter to act as a computer terminal and display the incoming data exactly as it is received.

If the data displayed on the screen are unrecognizable, you may have selected the wrong input parameters for your particular receiver, for example, Baud Rate 9600 instead of Baud Rate 4800. Check your receiver manual to be sure that you have selected the proper parameter. If the screen is blank, you may have a broken connection, and no data is being received or you may have connected the device to the other input port.

Use **[ZOOM IN]** to stop (or continue after pause) data displaying, **[ENT]** to show data in hex or ASCII mode (normal or small) and **[CLR]** to exit.

Loop-Back Test

This is a special test done during the production phase to check the serial ports integrity. A special connector is required.

19. SPECIFICATIONS

19.0 CP180/CP180i SPECIFICATIONS

Power Consumption	CP180i : 520mA max @12V CP180 : 460mA max @12V WITH EXTERNAL GPS CONNECTED CP180 : 410mA max @12V WITHOUT EXTERNAL GPS CONNECTED
Power supply	: 10-35 Volt DC
Interface	: Input/Output Interface NMEA-0183
Display	: TFT Color LCD (<i>active area 5"</i>) sunviewable technology
Display Resolution	: 320 x 240 pixels
Cartography	: C-MAP BY JEPPESEN NT*/MAX C-CARD
Operating temperature range	: 32°F/+131°F (0°C/+55°C)
Storage temperature	: -4°F/+158°F (-20°C/+70°C)
Water Resistance	: splash-proof
Memory	: Permanent
Keyboard	: Silicon rubber, backlight
Weight (without bracket)	: 1,322 lb (600 g)
User Points (Marks/Waypoints)	: 3000
Routes	: 50 (max 100 Waypoints each)
Track Points	: 10000 (recordable in 20 Tracks)
NMEA Output sentences	: GLL, VTG, BWC, WCV, APA, APB, HTG, BOD, XTE, RMA, RMB, RMC, GGA, HSC, DBT, DPT, MTW, VHW, WPL, RTE
NMEA Input sentences	: WDG, DSC, DSE, GGA, GLL, GSA, GSV, HDG, HDM, HDT, RMC, VHW, VTG, DPT, DBT, MTW, VWR, VWT, TLL, WPL, RTE

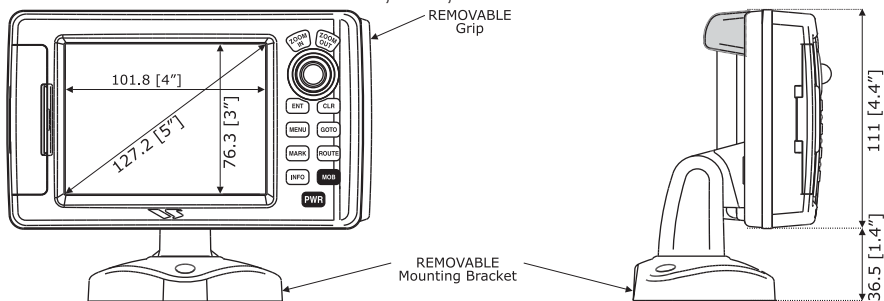

GRAY parts are present ONLY on CP180i

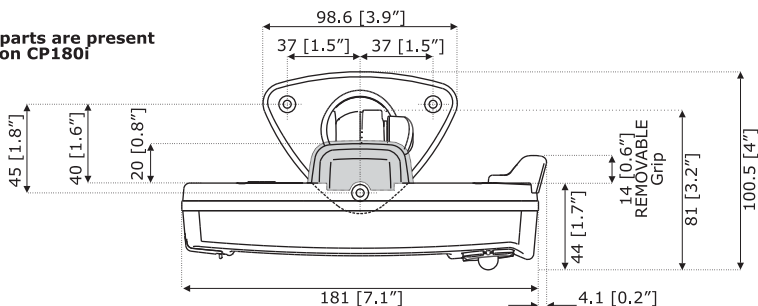

Figure 19.0 - CP180/CP180i Dimensions [mm/inch]

19.1 CP300/CP300i SPECIFICATIONS

Power Consumption	CP300i : 750mA max @12V CP300 : 750mA max @12V WITH EXTERNAL GPS CONNECTED CP300 : 700mA max @12V WITHOUT EXTERNAL GPS CONNECTED
Power supply	: 10-35 Volt DC
Interface	: Input/Output Interface NMEA-0183
Display	: TFT Color LCD (<i>active area 7"</i>) sunviewable technology
Display Resolution	: 800 x 480 pixels
Cartography	: C-MAP By JEPPESEN NT*/MAX C-CARD
Operating temperature range	: 32°F/+131°F (0°C/+55°C)
Storage temperature	: -4°F/+158°F (-20°C/+70°C)
Water Resistance	: splash-proof
Memory	: Permanent
Keyboard	: Silicon rubber, backlight
Weight (without bracket)	: 2,028 lb (920 g)
User Points (Marks/Waypoints)	: 3000
Routes	: 50 (max 100 Waypoints each)
Track Points	: 10000 (recordable in 20 Tracks)
NMEA Output sentences	: GLL, VTG, BWC, WCV, APA, APB, HTG, BOD, XTE, RMA, RMB, RMC, GGA, HSC, DBT, DPT, MTW, VHW, WPL, RTE
NMEA Input sentences	: BWC, DSC, DSE, GGA, GLL, GSA, GSV, HDG, HDM, HDT, RMC, VHW, VTG, DPT, DBT, MTW, VWR, VWT, TLL, WPL, RTE.

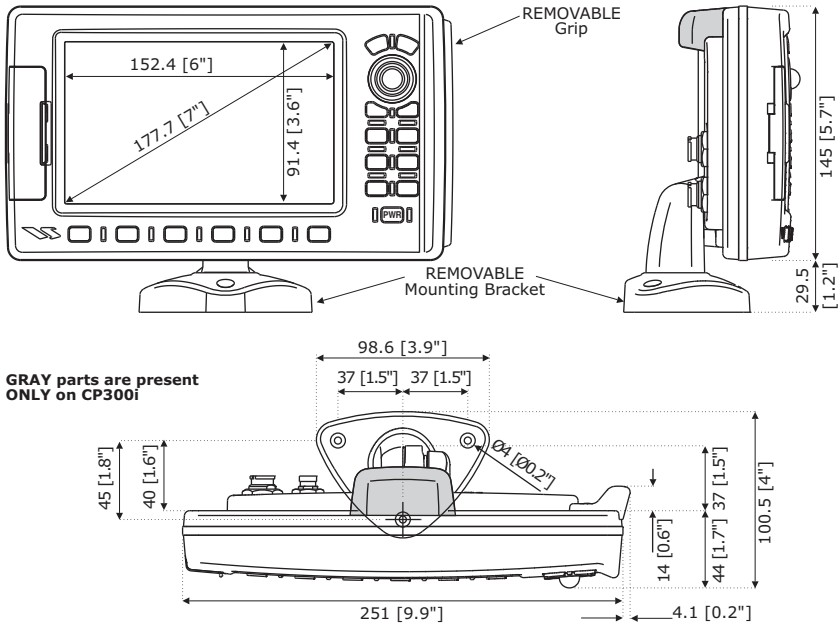

Figure 19.1 - CP300/CP300i Dimensions [mm/inch]

19.2 OPTIONAL WAAS GPS RECEIVER SPECIFICATIONS

This optional WAAS GPS Receiver is based on a ultimate GPS engine that delivers accuracy better than three meters by decoding the GPS correction signals from the satellite-based WAAS (*Wide Area Augmentation System*). The GPS engine, interface electronics and the passive antenna are enclosed inside the waterproof plastic housing. This provides advanced state of the art GPS performance in an easy to use package.

Physical Characteristics

Color	Ivory white
Dimensions	97mm in diameter x 32mm in height (flush mounted) or 61,5mm on flag-pole mount
Weight (without cable)	0,35 lb (160 g)
Cable	white 15 meter 8x28AWG cable with 6 pins female connector

Electrical Characteristics

Input Voltage	10 Vdc to 35 Vdc unregulated
Input Current	0.8 Wmax
GPS Receiver Sensitivity	Tracking, Navigation : -160 dBm Acquisition, Reacquisition : -160 dBm Cold Starts : -145 dBm

GPS Performance

GNSS Systems	GPS : L1 C/A GALILEO : L1 SBAS : WAAS (North America), EGNOS (Europe), MSAS (Asia), GAGAN (Indian)
Geodetic Datum	WGS84
Channels	32 + 18

Acquisition Time

Reacquisition	< 1 second
Hot Start	1 second outdoor, 10 seconds indoor
Warm Start	29 seconds
Cold Start	29 seconds

Accuracy

GPS	< 2.5m
with SBAS	< 2.0m

NMEA Output

Messages	GGA, RMC, GSA, GSV, TXT
----------	-------------------------

20. APPENDIX: TERMS

ALT (Altitude) – Shows the Altitude of the GPS Antenna on the mean sea level. It is received from GPS, sentence GGA.

APP Wind DIR SPD (Apparent Wind Direction) – Shows the Apparent Wind Direction when an external wind instrument with NMEA is connected.

APP Wind SPD (Apparent Wind Speed) – Shows the Apparent Wind Speed when an external wind instrument with NMEA is connected.

BRG (Bearing) – The direction from your current position to a Destination point.

COG (Course Over Ground) – The course your vessel is heading.

DATE – Shows the current date received by the GPS.

DEPTH – Shows the water depth when the optional FF525 50/200kHz BLACK BOX FISH FINDER or Digital Depth Sounder is connected.

DEPTH AREAS – Depth Areas are the sea areas included in the user selectable range of minimum and maximum depth limits. The sea area that is **beyond** the selected range is filled by a uniform white color, the sea area that is **inside** the selected range is filled by ordinary multicolor shading. The Spot Soundings and Depth Contours are displayed on the range only.

DRAUGHT – Depth of water the vessel draws.

The definition of **draught** (or **draft**) of a ship's hull is the vertical distance between the waterline and the bottom of the hull (keel). Draught determines the minimum depth of water a ship or boat can safely navigate. On the Celestial page the “**draught**” window shows the height of the tidal water during a 24hr period of time. This height is dependant on the time of day selected using the ShuttlePoint knob.

DSC (Digital Selective Calling) – Digital Selective Calling is a semi-automated method of establishing a VHF Radio call. DSC had also been designated as part of the Global Maritime Distress and Safety System (GMDSS). It is planned that DSC will eventually replace aural watches on distress frequencies and will be used to announce routine and urgent maritime safety information broadcasts.

DST (Distance) – The distance from your current position to a Destination point.

ETA – Estimated Time of Arrival

GPS Constellation – The Global Positioning System (GPS) is a space-based radio-navigation system consisting of a constellation of satellites and a network of ground stations used for monitoring and control. A minimum of 24 GPS satellites orbit the Earth at an altitude of approximately 11,000 miles providing users with accurate information on position, velocity and time anywhere in the world and in all weather conditions.

GPS2D – The GPS is receiving at least 3 valid satellites.

GPS3D – The GPS is receiving at least 4 Satellites.

HDG (Heading) – Shows heading from an External Flux Gate Compass when connected.

HDOP/VDOP – Horizontal/Vertical Dilution of Precision. It is a parameter indicating the precision of the positioning system (GPS). The smaller the HDOP/VDOP value, the more accurately the position fix is provided.

HEIGHT – The current tide height referred to the vertical cursor.

HIGH WATER – The maximum level of the tide height in 24 hours.

LOW WATER – The minimum level of the tide height in 24 hours.

PINGO – It is a mound of earth-covered ice found in the Arctic and subarctic that can reach up to 70 metres (230FT) in Height and up to 600 metres (2,000 FT) in diameter.

Position Request – Marine DSC VHF Function of transmitting a GPS position to another Marine DSC VHF. When GPS Chart Plotter is connected to STANDARD HORIZON GPS the position of another vessel is shown on the Chart page.

SPEED – Shows the Speed Thru the Water when a Digital Speed Log is connected.

SOG (Speed Over Ground) – The speed you vessel is travelling at.

STEER – Heading to steer to destination Waypoint.

TIME – Shows the current time received by the GPS.

TRIP LOG – Shows the distance the vessel has travelled since the trip log was reset.

TRU Wind DIR (True Wind Direction) – Shows the True Wind Direction when an external wind instrument with NMEA is connected.

TRU Wind SPD (True Wind Speed) – Shows the True Wind Speed when an external wind instrument with NMEA is connected.

TTG (Time To Go) – Shows time to go to reach a Destination point.

UNITS

Nm Nautical Mile (1 NM = 1.15 Sm or 1.85Km)

Sm Statue Mile (1Sm = 0.87Nm or 1.61Km)

Km Kilometer (1 Kilometer = 0062 Sm or 0.54Nm)

FT Feet (1 Foot = 0.167 Fathoms or 0.305 Meters)

FA Fathom (1 Fathom = 6 Feet or 1.83 Meters)

Mt Meter (1 Meter = 3.28 Feet or 0.55 Fathoms)

Kts Knot (1 Knot = 1.15 MPH or 1.85 KPH)

MPH Miles Per Hour (1 MPH = 0.87 Knots or 1.61 KPH)

Kmh Kilometer Per Hour (1 KPH = 0.54 Knots or 0.62 MPH)

VMG – It is the destination closing Velocity. The VMG is calculated using the current speed of the vessel (SOG) and the difference between the current vessel course and the bearing to the Destination.

WAAS 2D/3D – The GPS is receiving a 2D or 3D position and the correction from the WAAS Satellite. WAAS consists of approximately 25 ground reference stations positioned across the United States that monitor GPS satellite data. Two master stations, located on either coast, collect data from the reference stations and create a GPS correction message. This correction accounts for GPS satellite orbit and clock drift plus signal delays caused by the atmosphere and ionosphere. The corrected differential message is then broadcast through one of two geostationary satellites, or satellites with a fixed position over the equator. The information is compatible with the basic GPS signal structure, which means any WAAS-enabled GPS receiver can read the signal.

WATER TEMP – Shows the sea water temperature when the FF525 50/200kHz BLACK BOX FISH FINDER or a Digital Speed Log/Temp instrument with NMEA is connected.

XTE (Cross Track Error) – The distance your vessel is off course (left or right) to a Destination point.

ANALYTICAL INDEX

A

About page 39, 115
Accessories 12
Accessory 12
Accuracy 127
ACQUIRING 97
Acquisition Time 127
Activation Range 108
Active Target 107
ACTIVE TRACK 80
ACVC10 cable 26
Advanced Setup menu 103
AIS 18, 19, 21, 22, 23, 24,
38, 107, 109
AIS LIST 38
AIS List 11
AIS List page 109
AIS MENU 108
AIS receiver 24
AIS Setup 21, 23
AIS Symbols 108
Alarm 104, 107
alarm conditions 76
Alarm Status List 118
ALT 89, 129
Alter 35, 104
Alternate Solution 104
Altitude 38, 89, 129
Anchor Alarm 105
antenna 17, 121
APA 125, 126
APB 125, 126
Apparent Wind Direction 89, 129
Apparent Wind Speed 89, 129
Arrival Alarm 104
ASF1/2 35, 104
assistance 11
Attention Areas 91
Audible Alarm 105
Auto Info 39, 106
Auto Position 106
Auto Switch 27
Automatic Route Check 76
Autopilot 19, 21, 22, 24
AWD 89
AWS 89

B

back up 83
background 11, 29, 86
Backlight 30, 33, 123
Bathymetric 51
Bathymetric Lines 92
BATTERY CONNECTIONS 23
Beacon 91
Bearing 89, 129
Bearings 104
BOD 125, 126
Bracket installation 15
BRACKET MOUNTING 15
BRG 89, 129
brightness 123
Buoy 90, 91
BWC 98, 125, 126

C

C-CARD 5, 51, 52, 124
C-CARD Connector 124
C-CARD Test 124
C-COM 111
C-Weather 111
C-Weather loading 112
Calibration 104
Cartographic Data 52
Cartography 11, 125, 126
Cartridges 124
CAUTION 5
Caution page 30
CELESTIAL 38
Celestial page 96
Chain 35
change the scale 29
Changing date 96
Channels 127
CHART 37
Chart Boundaries 91, 93
Chart Language 59
Chart Lock 91, 94
Chart page 31, 86
Chart Scale 29, 89
Chart selection menu 86
Chart Settings 93
CHART/COMPASS 37
CHART/HIGHWAY 37

Classic	36, 39	customize data fields	29
Cleaning screen	5	Customizing the Data Windows	88
Clear Info	52	D	
clear internal memory	123	dangerous objects	76
Clear View	52	dangerous Route leg	76
clearing RAM	123	Dangerous Target	107
CLR	27, 29	Data Features	51
COG	89, 129	data fields	11, 88
COG TIME LINE	39	Data Safety Indicator	94
Color (Route)	75	Data window layout	88
Compass Rose	95	DATE	89, 129
Compass Tape	95	Date	96, 105
Connection	20, 22	DATE FORMAT	38
Connection (MOBILARM)	113	Daylight Saving	38
Connection Table	18, 19	daylight savings time	34
CONNECTIONS	18, 23	DBT	98, 125, 126
Contrast	30, 33, 121, 123	DC Power Connection	20, 22
conventions	15	delete a Route	75
Coordinate System	35, 103	Delete PTX	117
Coordinate System menu	35	Deletes a Track	80
Coordinates	48, 49	Deleting a file	84
correct time	34	Deleting a Mark	64
Course	105	Deleting a Waypoint	64
Course Over Ground	89, 129	Deleting MOB	69
Course Up	33	Demo Mode	28, 106
Course Up/North Up menu	33	DEPTH	129
CP180	103	Depth	38, 89
CP180/CP180i11, 12, 15, 18, 20, 125		Depth Alarm	104
CP180i	103	Depth Area	92, 129
CP300	103	Depth limit	77
CP300/CP300i		Depth Range Max	91, 92
11, 12, 15, 19, 22, 26, 30, 37, 126		Depth Range Min	91, 92
CP300i	103	Depth Settings	92
CPA	107	Depth Sounder	24, 98
CPA Alarm	107, 108	Depth Sounding	92
CPA Limit	107, 108	DEPTH TREND	38
Creating a Route	71, 73	Depths	51
Cross Track Error	89, 131	destination	29
Current Date	89	Differential Correction Source	98
Current Time	89	Diffusers	76, 91, 94
Currents	91	Digital Depth Sounder	100
Currents Prediction	58	Digital Selective Calling	101
Cursor	67	DIM Menu	123
Cursor Control	106	Dimensions	125, 126
cursor icon	31	disable Demo mode	28
Cursor Mode	29, 31	Display	125, 126
CURSORS POSITION	39	Display (AIS)	108
CURSORS SPEED	39	DISPLAY COLOR	38
Cursor Speed menu	32	Display Color menu	36
CURSORS WINDOW	39	Display Mode	90
Custom	90	Display Resolution	125, 126

Distance	38, 89, 129	FISH FINDER 50kHz/CHART	38
Distance Units (track)	79	Fishing Facility	76
Distress call	101	Fix Status	89
Download Area	112	Flexi-Zoom	52, 53
download weather data	111	Flush installation	16
DPT	98, 125, 126	FLUSH MOUNTING	16
Draught	96, 129	Flush mounting	17
Dredged Areas	76	Flux gate compass	98
DSC	11, 24, 98, 101, 106, 125, 126, 129	Focus	87
DSC DIRECTORY	38	forecast	111
DSC Distress Call	102	Format User C-CARD	83
DSC LOG	38	FT Feet	130
DSC VHF Radio	24	Full Info On Lakes	46
DSE	98, 125, 126	Full Screen View	27
DSI	94	G	
DST	89, 129	GENERAL SETUP menu	38
DTP	89	General Window	88
Dual	86	GGA	98, 125, 126, 127, 129
DUAL CHART	37	GLL	98, 125, 126
Dual chart window	11	GMDSS	101, 129
DVD Input	26	GOTO	29
Dynamic Currents	52	GOTO CURSOR	67
Dynamic Nav-Aids	52	Goto PTX	117
E		GOTO ROUTE	68
EDIT	65	GOTO ... 11, 16, 97, 98, 121, 127, 129	129
EDITING A MARK	63	GPS antenna	16, 121
egg timer	86	GPS Chart Plotter	11
EGNOS	97	GPS Constellation	129
Electrical Characteristics (antenna)	127	GPS information	98
Electronic charts	4	GPS Performance	127
enable Demo mode	28	GPS Receiver	127
Enhanced Mixing Levels	52	GPS Setup Menu	98
Enhanced Port Info	52, 61	GPS Status	38, 89, 97
ENT	29	GPS Status page	31, 97
Estimated Time of Arrival	89	GPS2D	97, 129
ETA	89, 129	GPS3D	97, 129
Extra Large Coverage	51	Ground Alarm Range	105
F		Grounding Alarm	105
FA Fathom	130	Grounding Alarm Report	105
FCC	4	GSA	98, 125, 126, 127
features	11	GSV	98, 125, 126, 127
FF525	11, 21, 22, 24, 38, 79, 100, 129, 131	Guardian Alarm	52
FIND	38, 65	H	
Find	52	HDG	89, 98, 125, 126, 129
FISH FINDER	11, 24, 38, 103	HDM	98, 125, 126
FISH FINDER 200kHz	38	HDOP	89, 97, 130
FISH FINDER 200kHz/CHART	38	HDT	98, 125, 126
FISH FINDER 50/200kHz	38	Heading	89
FISH FINDER 50kHz	38	HEIGHT	130
		HIGH WATER	130
		HIGHWAY	38

Highway page	96
Home Mode	29
Home mode	31
Horizontal Dilution of Precision ..	89, 97
HSC	125, 126
HTG	125, 126
I	
ICON	65
Icons Size	54
INFO	30
information	49, 90
Information page	39
Input Data Display	124
INPUT/OUTPUT	103
Inserting C-CARD	51
Installing the External GPS Antenna	17
Interface	125, 126
Interfacing to VHF Radio	101
Internal GPS	98
Intertidal Areas	76
ISO Certification	51
K	
Keyboard	125, 126
KEYPAD BEEP	38
keypad light	123
keys	29
Km Kilometer	130
Kmh Kilometer Per Hour	130
Kts Knot	130
L	
Lakes By Name	47
Lakes Information	45
Land Areas	76
Land Elevation Values	91, 92
Land Elevations	51, 91, 92
Land Settings	92
Language	36, 39, 59
Language Selection	37
Lat/Lon Grid	91, 93
Latitude	35, 93
LCD	125, 126
LCD display	11
legend	15
Lights	90, 91
limited warranty	11
Loading a file	84
Local area names	91
LOCATE	65
Longitude	35, 93
Loop-Back Test	124
Loran TD	35, 104
Lost Target	107
LOW WATER	130
M	
Magnetic bearings	104
Main Menu	29, 85
Map Datum	103
Map Functions Menu	53
Map Orientation Resolution	103
Marine Settings	91
MARK	30
Mark	11, 30, 48, 63, 64, 65, 66, 67, 68, 71, 73, 83, 125, 126
Mark creation	63
Mark editing	63
MARKS/WAYPOINTS	38
Marks/Waypoints List	66
MEASURE DISTANCE	39
Memory	123, 125, 126
MENU	29
Mixing Levels	91, 94
MMSI	107
MMSI number	107
MOB	30, 69, 115
MOBILARM	24, 113
MOBILARM Alarm Status	118
MOBILARM PTX	115
MOBILARM Status	114
MOBILARM System	24
Mooring	76
MOUNTING	15
Moving a Mark	64
Moving a Waypoint	64
MPH Miles Per Hour	130
Mt Meter	130
MTW	98, 125, 126
Multilanguage Support	52
Multimedia Object	60
N	
Name	107
Name Tags	91
name the Route	71
nautical charts	4
Nav Aids & Light Sectors	91
NAV AIDS PRESENTATION	38
Navigate menu	103
Navigating a Route	106
NAVIGATION	38
Navigation Data page	95
Navigation Speed	98
new Mark	65, 66
new Route	73

new Track	80	Ports & Services	91, 92
Night	36, 39	Position Request	101, 102, 130
Nm Nautical Mile	130	POSITION Send	101
NMEA	23, 25, 103, 125	Power Consumption	125, 126
NMEA CONNECTIONS	23	Power On	30
NMEA DATA	38	Power supply	125, 126
NMEA Data page	11, 25, 99, 100	Presentation Features	52
NMEA Display	38, 98	Production Installation	76
NMEA Display menu	99, 100, 101	PTX	115
NMEA Input	11, 103, 125, 126	PTX icon	115
NMEA Output	11, 103, 125, 126, 127	PTX information	116
NMEA RTE	65, 75	PTX List page	118
NMEA sentences	98	PTX warning window	115, 116
NMEA Trend page	100	PWR	30
NMEA WPL	65	Q	
NOAA	36, 38, 39	QUICK INFO	109
Normal	36, 38	Quick Info	52
North Up	33	Quick Info On Lakes	45
NTSC	26	R	
O		RADAR	11, 24, 38
Object Info	52	Radar	13, 24, 90
Obstructions	44, 76, 91, 94	RADAR CHART	38
Off-line redraw	52	RADAR FULL	38
Official data source	51	RADAR OVERLAY	38
Olympic Route	11	RADAR/FISH FINDER	38
Outdoor Recreational Area	45	Radio Call Sign	107
Over-Zoom	54	RAM	123
P		RAM Clear	123
Packing List	12	RAM Menu	123
pages	85	Real Time View	112
Pair	35	RECEIVE	65, 75
PAL	26	receive User Points	66
PC-Planner	111	Refresh User C-CARD	84
Personal Computer	24	replacement part	12
Perspective View	52, 55	reset	123
Photos & Diagrams	52	Reset trip log	81
Physical Characteristics (antenna)	127	Resolution	125, 126
Picture in Picture	11, 26, 27	Restart GPS	98
Pictures & Diagrams	59	RESTORE DEFAULTS	27
Pin	111	Reverse Route	75
Pingos	76, 130	RMA	125, 126
PiP	27	RMB	125, 126
Place Names	91	RMC	98, 125, 126, 127
Place Names size	54	Roads	52, 91, 92
PLACING A MOB	69	Rocks	76, 91, 94
Points Of Interest	47, 91, 92	ROUTE	30
polarity	121	Route	11, 30, 63, 67, 71, 74, 83, 106, 125, 126
Port	42, 90	ROUTE CHECK REPORT	77
Port Info	52, 61	Route Checking	11, 76
Port Plan	52	Route Report	72, 74, 76, 77
Port Services	41		

Route Width	77	Start-Up page	31
RTE	65, 75, 98, 125, 126	Static Navigation	104
S		STEER	130
safety of navigation	107	Steering	89
Safety Route Check	52	STOP Navigation	68
Safety Status Bar	56	STR	89
Safety Toolbar	52	Sunlight	36, 39, 121
Satellite	11, 97	SWITCHING TIMEOUT	27
Satellite Imagery	57	System Test	123
SCALE	89	T	
screen	5	Target	107
Screen display pages	37, 85	TCPA	107
Seabed Type	91, 92	TCPA Alarm	107, 108
Search	52	TCPA Limit	107, 108
Select Route	74, 75	TD	35, 103, 104
select the language	36	Temp	89
SEND	65, 75	TEMP TREND	38
sentences	125, 126	temperature	38, 125, 126
serial interface	124	TERMS	129
Serial Ports	124	text area	88
Setup Menu	29	THICKNESS	75
Shallow Water	76	Tidal stream arrows	58
SHIP ICON	39	Tide	58, 96
Ships Icon	31, 32	Tide Graph	43, 96
Shoreline Constructions	76	Tide height	96
ShuttlePoint knob	29	Tide Stations	42, 90
SI-TEX	13	Tides & Currents	91
Signals	91	Tides Preview	52
SIM Pin	111	TIME	89, 106, 130
Simulation	105	TIME SETUP	38
Simulation Menu	28	Time Setup menu	34
Simulation Mode	105	Time To Go	89, 130
Single	86	Time Units (track)	79
Single Chart page	88	Time Zone	38
Sleeping Target	107	TLL	98, 125, 126
Sm Statue Mile	130	TLOG	89
Smart GPS Cable	18	Tower	90
Soft Keys	27, 30, 37, 86	Track	79, 83, 125, 126
SOG	89, 130	Track line	80
SOG TREND	38	Track Menu	80
SORT	65	Track point memory	79
SPD	89	Track Points	11, 79, 125, 126
SPECIFICATIONS	125, 126	Tracking	80, 81, 89
Speed	38, 89, 105, 130	Tracks & Routes	91, 92
Speed Log	24, 98, 100	Transferring files	83
Speed Over Ground	89	transmit User Points	66
Spot Soundings	51	Trip Log	80, 81, 89, 130
Standard (Zoom Type)	53	Trip Log selection	81
Standard Zoom	53	TROUBLESHOOTING	121
start a new Track	80	True bearing	104
start navigating	29	True Wind Direction	89, 130

True Wind Speed	89, 130	VWT	98, 125, 126
True-Type Font	52	W	
TTG	89, 130	WAAS	16, 89, 97, 121, 127, 130
TWD	89	WAAS 2D/3D	97, 130
TWS	89	WAAS GPS antenna	16, 121
TXT	127	WARNING	4
Type of Data	112	Warning alarm Icon	56
U		Warping Facility	76
Under-Zoom	54	warranty	11
Underwater Ob. Limit	91	Water Resistance	125, 126
Underwater Object Limit	94	WATER TEMP	131
Underwater Objects Settings	94	Water Temperature	89
UNITS	130	Waypoint	30, 63, 64, 65, 68, 71, 125, 126
UNITS OF MEASURE	38	Waypoints List	66
Universal Time Coordinates	34	WCV	125, 126
User C-CARD	38, 83, 111	Weather data package	111
User C-CARD Menu	83	Weather Forecast	112
User Points	48, 66, 125, 126	Weight	125, 126
UTC	34	WGS84	103, 127
UTM	35, 103	Wind direction	98
V		Wind Instrument	24
Value Added Data	91, 94	Wind speed	98
Variation	104	WIND SPEED TREND	38
VCR Input	26	Wind Speed/Direction	100
VCR/DVD Input	27	Window Selections	88
VDOP	89, 97, 130	WINDOWS SETUP	39
Velocity Made Good	89	World Background	51
Vertical Dilution of Precision	89, 97	Worldwide background	29, 86
VHF	21, 22, 24, 25, 107	WPL	65, 98, 125, 126
VHF radio call	101	Wrecks	43, 76, 90, 91, 94
VHW	98, 125, 126	X	
Video Camera Input	26	XTE	89, 104, 125, 126, 131
Video Connector	20, 26	XTE Alarm	104
Video Input	11, 26, 38	Z	
Video port	26	zoom	53, 54
VideoCamera	22	zoom factor	54
VISIBLE (track)	80	ZOOM IN	29, 53
VMG	89, 130	ZOOM OUT	29, 53
voltage	121	Zoom Type	53
VTG	98, 125, 126		
VWR	98, 125, 126		

PLEASE NOTE

The following "Limited Warranty" is for customers that have purchased products in the United States. For Limited Warranty details outside the United States, contact the dealer in your country.

STANDARD HORIZON LIMITED WARRANTY

STANDARD HORIZON (a division of Vertex Standard USA) warrants, to the original purchaser only, each new Marine Product ("Product") manufactured and/or supplied by STANDARD HORIZON against defects in materials and workmanship under normal use and service for a period of 3 years from the date of purchase.

In the event of a defect, malfunction or failure of the Product during the warranty period, Standard Horizon's liability for any breach of contract or any breach of express or implied warranties in connection with the sale of Products shall be limited solely to repair or replacement, at its option, of the Product or part(s) therein which, upon examination by STANDARD HORIZON, appear to be defective or not up to factory specifications. STANDARD HORIZON may, at its option, repair or replace parts or subassemblies with or reconditioned parts and subassemblies.

To receive warranty service, the purchaser must deliver the Product, transportation and Insurance prepaid, to STANDARD HORIZON (Marine Division of Vertex Standard) - Attention Factory Service - 10900 Walker Street - Cypress, CA 90630, include proof of purchase indicating model, serial number and date of purchase.

STANDARD HORIZON will not warrant installation, maintenance or service of the Products. In all instances, STANDARD HORIZON's liability for damages shall not exceed the purchase price of the defective Product. This warranty only extends to Products sold within the 50 States of the United States of America and the District of Columbia.

STANDARD HORIZON will pay all labor and replacement parts charges incurred in providing the warranty repair service except where purchaser abuse or other qualifying exceptions exist. The purchaser must pay any transportation expenses incurred in returning the Product to STANDARD HORIZON for service.

This limited warranty does not extend to any Product which has been subjected to misuse, neglect, accident, incorrect wiring by anyone other than STANDARD HORIZON, improper installation, or subjected to use in violation of instructions furnished by STANDARD HORIZON, nor does this warranty extend to Products on which the serial number has been removed, defaced, or changed. STANDARD HORIZON cannot be responsible in any way for ancillary equipment not furnished by STANDARD HORIZON which is attached to or used in connection with Products, or for the operation of the Product with any ancillary equipment, and all such equipment is expressly excluded from this warranty. STANDARD HORIZON disclaims liability for range, coverage, or operation of the Product and ancillary equipment as a whole under this warranty.

STANDARD HORIZON reserves the right to make changes or improvements in Products, during subsequent production, without incurring the obligation to install such changes or improvements on previously manufactured Products. The implied warranties which the law imposes on the sale of this Product are expressly LIMITED, in duration, to the time period specified above. STANDARD HORIZON shall not be liable under any circumstances for consequential damages resulting from the use and operation of this Product, or from the breach of this LIMITED WARRANTY, any implied warranties, or any contract with STANDARD HORIZON. IN CONNECTION WITH THE SALE OF ITS PRODUCTS, STANDARD HORIZON MAKES NO WARRANTIES, EXPRESS OR IMPLIED AS TO THE MERCHANTABILITY OR FITNESS FOR A PARTICULAR PURPOSE OR OTHERWISE, EXCEPT AS EXPRESSLY SET FORTH HEREIN.

Some states do not allow the exclusion or limitation of incidental or consequential damages, or limitation on how an implied warranty lasts, so the above limitation or exclusions may not apply. This warranty gives specific legal right, and there may be other right which may vary from state to state.