

HORIZON

Marine Electronics

GPS Track 240F Track Plotter

Owner's Manual

- Internal 12 Channel Rockwell GPS
- 500 Waypoints with 10 Quick Marks
- 20 Reversible Routes
- Unique Menu Driven System
- Built-in Datums and User Definable Offsets
- Fuel Screen Shows Used/Economy & Remaining
- Man Over Board Function
- Differential GPS Ready
- NMEA0183 Output for Autopilot or Repeater
- Swivel-type Gimbal Bracket



**Optional
Gas Fuel
Flow**



Contents

| | | |
|-------------|---|-----------|
| 1.0 | TP240F Introduction | 3 |
| 1.1 | The Global Positioning System (GPS) | 3 |
| 1.2 | Commonly Used Terms | 3 |
| 1.3 | Operating the TP240F | 4 |
| 2.0 | Overview | 6 |
| 3.0 | Man Over Board (MOB) Function | 7 |
| 4.0 | Start-up Sequence | 8 |
| 4.1 | Satellite Status Screen | 8 |
| 4.2 | Acquisition Period | 9 |
| 5.0 | Moving Around the Screens | 10 |
| 5.1 | Menus | 10 |
| 5.2 | Changing Names or Numeric Values within data fields | 10 |
| 5.3 | Screen Summary | 11 |
| 6.0 | Track Plot Screen | 12 |
| 7.0 | Position Screen | 13 |
| 8.0 | Highway Screen | 14 |
| 9.0 | Fuel Screen | 15 |
| 9.1 | Fuel used reset | 16 |
| 9.2 | Fuel used calibration (Transducer calibration) | 17 |
| 9.3 | Fuel remaining change | 18 |
| 9.4 | Fuel remaining low alarm | 18 |
| 10.0 | GoTo | 19 |
| 11.0 | Waypoints | 20 |
| 11.1 | Waypoints Screen | 20 |
| 11.2 | Creating Waypoints | 21 |
| | Creating a New Waypoint | 21 |
| | Saving the current boat position | 21 |
| | Saving the current cursor position | 22 |
| 11.3 | Viewing Waypoint Details | 22 |
| 11.4 | Changing Waypoint Details | 23 |
| 11.5 | Displaying a Waypoint | 24 |
| 11.6 | Deleting a Waypoint | 24 |
| 11.7 | Distance Calculations | 25 |

| | |
|---|-----------|
| 12.0 Marks | 26 |
| 12.1 Converting Marks to Waypoints | 26 |
| 13.0 Routes | 27 |
| 13.1 Creating a New Route | 27 |
| 13.2 Adding and Deleting Waypoints in a Route | 28 |
| 13.3 Starting and Canceling Routes | 29 |
| 13.4 Deleting a Route | 30 |
| 14.0 Setup | 31 |
| 15.0 Chart Datums | 33 |
| Appendix A – Specifications | 36 |
| Appendix B – Replacement Parts | 37 |
| Appendix C – TP240F Installation | 38 |
| Appendix D – Trouble Shooting Guide | 42 |

1.0 TP240F Introduction

Congratulations on purchasing a Horizon TP240F track plotter. The TP240F is a compact, ruggedly built, highly integrated navigation instrument that has been designed for ease of use. With this instrument you will be able to display your boat's position, track and destination. Complex navigation functions can be performed with a few simple key presses, taking the hard work out of navigation. TP240F owners have the option of using the integrated fuel computer to keep track of their boat's fuel usage. The fuel computer is suitable for all gas engine boats, either inboard or outboard, and single or twin engine. Fuel transducers must be purchased separately.

1.1 The Global Positioning System (GPS)

The GPS constellation comprises of 24 satellites orbiting the earth, providing a worldwide system for determining position. From any one point on the earth's surface up to 12 satellites are "visible" to the GPS receiver. The positions of these satellites are constantly changing. The TP240F antenna tracks all visible satellites simultaneously and selects four or more satellites that produce the optimum geometry and signal quality for determining an accurate value of the boat's latitude and longitude. The superior performance achieved with the TP240F 12 channel receiver provides increased accuracy and reduced Time to First Fix (TTFF).

Note: The USA Department of Defense introduces a varying offset, known as Selective Availability (SA), to degrade the accuracy of the civilian GPS signal. As an approximate guideline it is generally assumed that the accuracy obtained with SA active causes the GPS derived position to be within 100 meters of the true position 90% of the time and within 50 meters of the true position 50% of the time. On brief occasions the SA can cause the position error to exceed 300 meters.

The constantly varying SA offset causes small errors in the indicated boat speed and heading that may be noticeable at speeds of 5 knots or less. The position, speed and heading errors have been deliberately designed into the system and affect all GPS receivers in the same way. They can be eliminated by connecting a differential (DGPS) receiver to the TP240F.

In times of military conflict, the USA Department of Defense has been known to turn the civilian GPS signal off. This is an extremely rare event, but should be guarded against by always having a secondary means of navigation to fall back on. The warning screen that appears each time the TP240F is turned on has a reminder to this effect.

1.2 Commonly Used Terms

Waypoints Positions such as fishing spots, favorite anchorages, dive locations and trip destinations can be saved in the TP240F's memory. These are referred to as waypoints. Up to 500 waypoints can be stored in memory. The TP240F will automatically allocate a name to a waypoint or the user can specify a name. Waypoints are created by saving the boat position, saving the screen cursor position or by entering the latitude and longitude of a location.

| | |
|--------------|---|
| Marks | Marks are temporary waypoints. They are created by a single press of the power on/off key. Marks can be created at any time, regardless of the screen currently displayed. Pressing the Mark key will save the current boat position with a temporary name in the range of MARK0 to MARK9. Marks are saved separately from normal waypoints. They are simpler to create and display and are intended to provide a simple method of marking temporary locations such as fish strikes. See section 12.0 Marks for a more detailed description. |
| Route | Two or more waypoints can be linked in sequence to form a route. The route has a start and end waypoint and can be traversed from start to finish or in reverse. Up to 20 routes can be stored in memory. |
| Legs | Legs are the division of a route between waypoints. A route consisting of four waypoints will have three legs. |
| GoTo | The GoTo function allows you to navigate from your current position to any waypoint or mark. The TP240F will guide you to your destination with a graphical highway screen and continuously updated navigational data. |

1.3 Operating the TP240F

You can use your TP240F to get you back to a good fishing spot or to sail all the way around the world. It has been designed to be easy to use for those with no formal navigation training, but also provides accurate navigational information for the long distance sailor. No matter how long or short your journey, the TP240F will take you straight to where you want to go.

If your main interest is in returning to previously visited locations such as good fishing spots, you should start by reading section **11.2** on saving the current boat position as a waypoint, then section **10.0** on how to “goto” a waypoint. It is normally advisable to take the time to enter a descriptive name for the waypoint as it quickly becomes difficult to remember which is which when the number of waypoints has built up. Be sure to save the position of the launching ramp before you start out so that you can use the TP240F to find your way back if there is fog, rain, or it gets dark on the return journey. This also applies to any point on your outward journey where you have to change course, such as a channel between two islands.

Note the warning in section **1.1** on the position errors introduced by SA. If you do not have a differential (DGPS) receiver, don't try and navigate through narrow channels in reduced visibility or darkness unless you have a secondary method of determining a safe course, such as a marine chart and a depth sounder.

Working With Charts

If you want to navigate to a location that you don't already have saved as a waypoint, you will need to obtain its latitude and longitude from a marine chart. See section **11.2** on how to create a new waypoint and enter Lat/Lon values. A pair of dividers is normally used to measure latitude and longitude on a chart. To measure the latitude of a location, place one point of the dividers on the location and then adjust the dividers until the other point is straight above or below the first one and on the nearest horizontal grid line. Move the dividers along the grid line to the latitude scale on the side of the chart. Put one point on the grid line and the other on the latitude scale and read the value. It will be a number like 43°52'13" N. A minute (') is one sixtieth of a degree. The N indicates this location is in the northern hemisphere. Unless you have a chart that covers a very small area, you won't be able to read the latitude scale more accurately than two decimal places of minutes. The

TP240F allows for three decimal places, so just put zero in the last place. The same method is used to measure the longitude, using a vertical grid line and the longitude scale at the top or bottom of the chart. The longitude will be a number like 010°32'95" E. Three digits are used for the degrees as longitudes can be as large as 180°. The E indicates this location is east of Longitude 000°, a vertical line through Greenwich (London). If you don't have a pair of dividers, you can use a ruler or even two pencil marks on the edge of a strip of paper.

When entering the Lat/Lon of a waypoint from a chart, it is essential that the TP240F is set to the same Lat/Lon datum that the chart uses (see section **15.0 Chart Datums**). This also applies if you are plotting the current boat position onto a chart. The datum will be given in the chart's title block.

If you use waypoints from a chart, it is a good idea to clearly mark the waypoints on the chart. Then, before you start navigating to a waypoint, you can draw a straight line from the boat's current position to the waypoint and check that it doesn't pass too close to any rocks or shoals. A similar idea is to enter any isolated rocks in your area as waypoints with the rock symbol (⚓). When you start navigation to a waypoint, the TP240F draws a line from the current boat position to the waypoint on its Track Plot screen. By looking at this screen you can check whether your intended course passes too close to any isolated rocks.

Fuel Functions

The TP240F's fuel computer functions enable you to keep track of how much fuel you have used, how much you have remaining, the rate at which fuel is being consumed, and how far you are travelling for every liter or gallon of fuel used. The fuel used value can be cleared to zero at any time so that you can keep track of the amount of fuel used for each trip, or for each season, or since you bought the boat, according to your preference. The fuel remaining value, on the other hand, must be updated each time you refuel so that you always know how much fuel is left in the tank. There is a low fuel alarm associated with the fuel remaining value that can be set to warn you when the fuel in the tank falls below the alarm level. You can set the alarm level to suit the size of the boat's engine and the distance you intend to travel.

The fuel consumption (titled FLOW on the screen) in liters or gallons per hour is shown. For twin engine installations, the consumption for each engine is shown separately. This is useful for checking that both engines are under the same load.

As the TP240F has both boat speed and fuel consumption values, it is able to calculate the current economy rate. This is the distance the boat is travelling for every unit of fuel used. The economy rate figure, depending on which distance unit and fuel volume unit the TP240F is set to, will have units like miles per gallon or kilometers per liter. As the speed error cause by Selective Availability becomes significant at low boat speeds, the economy rate is not displayed for speeds of 5 knots or less. If the TP240F is receiving corrections from a differential receiver, the economy rate is displayed whenever the boat speed is above 1 knot.

Optional Transducers

FT100 – Fuel Transducer

TEK100 – Twin-Engine Kit (includes additional FT100 and a 'Y' cable)

2.0 Overview

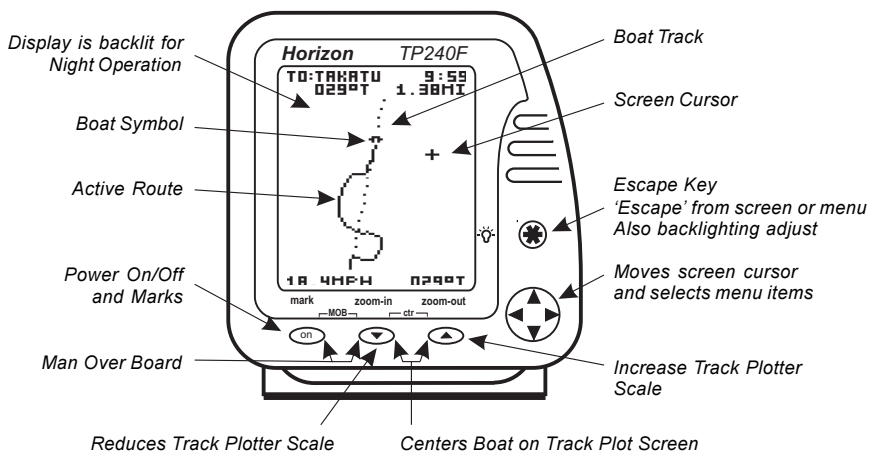

Power On/Off and Mark Key

The power on/off key performs a number of functions. First, to switch on the TP240F, momentarily press the Power on/off key. To switch the TP240F off, press and hold the key until the display becomes blank.

The Power on/off key also functions as the **mark** key. The **mark** key provides a quick method of saving the current boat position. See section **12.0 Marks**.

-MOB- Keys

Press the power on/off key and the **zoom-in** key together to activate the Man Over Board (MOB) function. See section **3.0 Man Over Board (MOB) Function** for further details.

Escape Key *

The * key is used to back out of sub screens or sub menus. When stepping through TP240F screens you can press the * key to return to the screen previous to the one currently displayed. Each time the * key is pressed you will 'step back' one screen. The * key is also used to control the backlighting level. Press and hold the * key to automatically step through five backlight levels. Release the key when the required backlight level is obtained.

Cursor Keys

The cursor keys control the movement of the screen cursor while in the Track Plotter mode. Movement in eight directions is possible. The cursor keys are also used to select and edit data such as setup information in the Setup screens, waypoint data, and route configurations. See section **5.0** for further details. In simulation mode these keys control the simulated speed and heading.

zoom-in, zoom-out keys

The Zoom In and Zoom Out functions are only active while the Track Plot screen is displayed. The scale of the displayed track plotter area can be instantly changed by pressing the **zoom-in** or **zoom-out** key. To see more detail press the **zoom-in** key. To see a larger area but less detail press the **zoom-out** key. When any list is displayed, such as waypoints or datums, the **zoom-in** key will step down through the list a screen at a time. The **zoom-out** key will step up through a list in the same manner.

-ctr- Keys

The center function is also only active while the Track Plot screen is displayed. The center function positions the boat in the center of the Track Plot screen. Momentarily press the **zoom-in** and **zoom-out** keys at the same time to activate the **-ctr-** function. This function is also an effective method of 'finding' the boat when initially not displayed on the screen.

3.0 Man Over Board (MOB) Function

The MOB function allows the boat's position to be immediately saved as a waypoint named MOB, and to immediately start navigating to it. The MOB function can be activated from any screen.

The following sequence activates this function:

1. Momentarily press the keys labeled MOB (**on** key and ▼ key). The boat's current position is stored as a waypoint with the name MOB.
2. The TP240F beeps ten times to indicate that the MOB function has been initiated.
3. A user prompt will appear asking if you are ready to start navigating to the MOB location. This gives you the opportunity to disable the autopilot, if currently active. If the autopilot is not active, press the ► key to immediately start navigating to the MOB location.
4. The display mode is automatically changed to the Highway screen, with the TP240F navigating to the MOB waypoint.

4.0 Start-up Sequence

Press the **on** key to switch the power on.

To switch the power off, press and hold the **on** key until the display goes blank.

Immediately after power-up the unit will display the software version number and a GPS navigation warning.



Press any key to proceed and start normal TP240F operation. The satellite status screen will be displayed until the TP240F receives a valid position fix from the antenna or the ***** key is pressed.

4.1 Satellite Status Screen

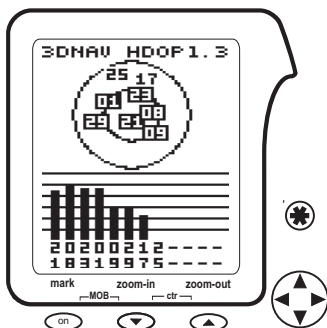

During satellite acquisition the satellite status screen displays the following information.

- The top left corner of the display indicates satellite acquisition status.
 - ACQ Receiving satellite data and acquiring a position fix.
 - 2D NAV Obtained a limited, two dimensional, position fix. The altitude is locked to the last known altitude. This situation arises if the GPS receiver does not have a clear view of the sky and is unable to track all available satellites.
 - 3D NAV Obtained a valid three dimensional position fix.

DIFF Operating in differential GPS mode. Indicates that TP240F is receiving valid RTCM 104 data and that lat/lon values provided by the TP240F have had differential corrections applied.

Using differential GPS (DGPS) will improve receiver accuracy to 5-10 meters, regardless of errors introduced by the USA Department of Defense Selective Availability program.

- The top right corner indicates the geometric accuracy of the position fix, known as the Horizontal Dilution of Precision (HDOP). A low number indicates a more accurate position fix.
- The central area of the display indicates the position of each satellite. The outer circle represents the horizon (north = top center), while the inner circle represents 45° above the horizon. The center point is directly overhead. Satellites used in the current position calculation are shown highlighted (reverse text).
- The lower part of the display is made up of a bar graph, indicating the signal strength of each satellite. Each of the horizontal lines is spaced 5dBHz apart with the lowest line representing 25dBHz.

The above information will remain displayed for 5 seconds after a position fix has been obtained. The acquisition process is fully automatic and requires no user intervention.

Following the above power-up sequence the TP240F will display the Main Menu screen. See section **5.0** for more details.

4.2 Acquisition Period

The time from initial power-up to the time the TP240F calculates the latitude and longitude of the current position is known as the Time To First Fix (TTFF). The TTFF varies in relation to a number of factors, but primarily varies due to the amount of time that has passed since the TP240F last obtained a fix. If the TP240F has a clear view of the sky it will typically acquire a position in 45 seconds. The TTFF may extend out to a few minutes if the TP240F has not been used for periods longer than a few months or if the TP240F has moved a significant distance, typically greater than 300 miles (500 km), since the last time it was used, it will automatically go into a cold start mode and “search” the sky for satellites. This is fully automatic and requires no user intervention. In the cold start mode the TTFF may extend out to 8 minutes in the worst case. The TTFF is also influenced by the current satellite geometry and position of the antenna. The antenna must have an unobstructed view of the sky.

The TP240F will always do a cold start the first time it is turned on. Once it has obtained a fix, switch to the Track Plot screen and press the **-ctr-** keys to initialize the Track Plot screen boat and cursor positions.

5.0 Moving Around the Screens

After the power-up sequence has been completed, the Main Menu screen will be displayed, as shown below.

All TP240F screens are accessed from this screen. Graphical screens showing boat position and navigation data are available from this screen, along with waypoint and route management features, fuel flow and instrument setup screens. The Satellite Status screen, displayed at power-up, can also be accessed from this screen.



5.1 Menus

The cursor keys are used to highlight menu items on screens such as the Main Menu screen, Setup, Waypoints and Routes screens. Press the ▲ or ▼ key to step up/down the menu items to highlight the item you wish to change or view. Press the ► key to select the highlighted item and move to the associated sub-screen. Press the * key to return to the previous screen.

The sub-screen selected may provide another list of related screens. The cursor keys can then be used to highlight and select an item from the list, allowing you access to the next subscreen. This hierarchical approach of stepping through various levels of screens is used throughout the TP240F. It is important to note that you are able to step back to previous screens by pressing the * key. Each time the * key is pressed you will return to the previous screen displayed. Eventually, by repeatedly pressing the * key, you will return to the Main Menu screen.

5.2 Changing Names or Numeric Values within data fields

The method described above also applies when a name or multi-digit number needs to be changed, for example waypoint names and waypoint lat/lon values. See section **11.0 Waypoints** for a detailed explanation of waypoints. Once information for a particular waypoint is displayed the ▲ or ▼ keys can be pressed to highlight the name or data you wish to change (waypoint lat/lon, symbol, etc).

After a value has been selected by pressing the ► key, the display will highlight the first character, indicating that you are able to change it. Press the ▲ or ▼ key to scroll through the letters of the alphabet and numbers 0-9. After you have reached the required letter or number press the ► key to move to the next character within the name or data. When you have completed all changes press the * key to finish editing the value.

5.3 Screen Summary



Track Plot Screen

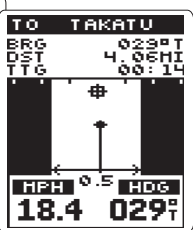

Highway Screen

Two graphical screens simplify navigation. The **Track Plot Screen** provides you with a graphical representation of your previous travel as well as your planned route. The **Highway Screen** provides a graphical birds-eye-view to your destination

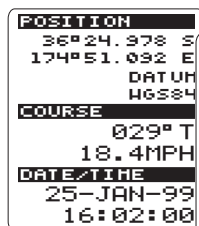

Navigation Data

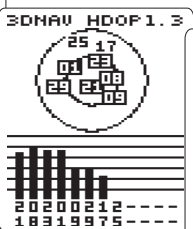

Satellite Status

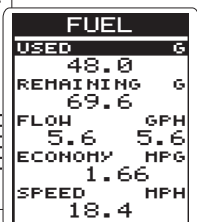

Fuel Data

Three data screens enable easy access to essential information such as navigation data, satellite status, and fuel information.

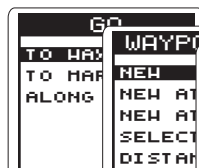

Navigation functions, waypoint and route construction, and general setup parameters are accessed from five subscreens.

6.0 Track Plot Screen

The TP240F features a Track Plot Screen that plots your current position and course. The current vessel speed and heading are also shown in the lower section of the screen. To display the Track Plot screen select the TRACK function from the Main Menu screen. Details of the Track Plot screen are shown below.

Note: The Track Plot screen is oriented in the same way you view a map or chart. North is toward the top of the screen.

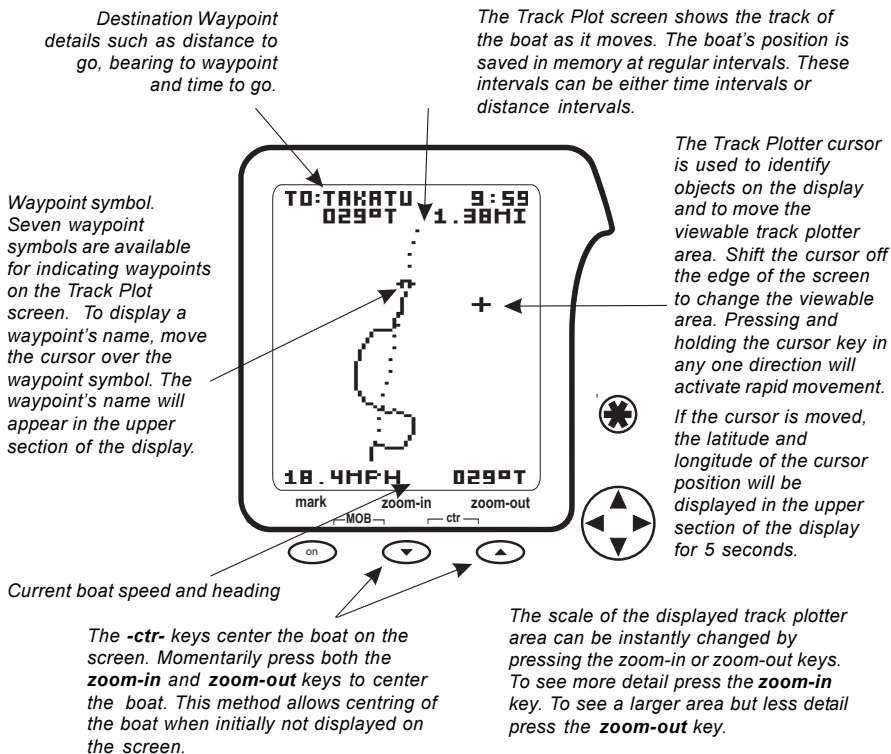

Scale

The scale is momentarily displayed in the upper left corner of the Track Plotter display whenever the cursor is moved or a zoom key is pressed. The scale can be adjusted from 0.1 to 500 miles/kilometers by pressing the **zoom-in** or **zoom-out** keys. The figure displayed is the vertical distance from the top to the bottom of the displayed area.

7.0 Position Screen

The TP240F's position screen displays navigation data: speed, course, time/date, position and datum.

The latitude and longitude of your current boat position is displayed at the top of the display along with the chart datum currently selected.

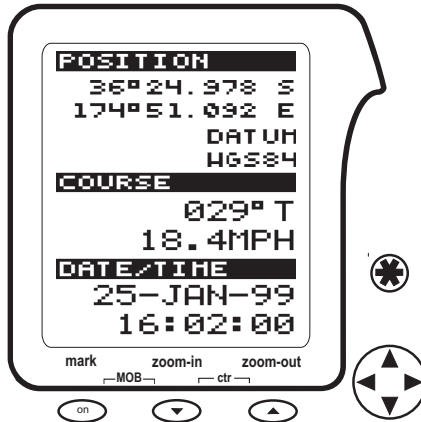

8.0 Highway Screen

The Highway screen provides a graphical 'highway' representation that shows your movement relative to your desired course. The highway is drawn from your original start point to a selected destination point. In the Highway screen the destination is positioned at the top of the display and the boat position is automatically maintained in the central area of the display. A bird's-eye view of the highway is displayed on the screen. This provides a simple and effective method of seeing exactly where you are in relation to your intended course. The width of the highway can be set to between 0.1 and 5.0 miles or kilometers. The larger widths are mostly of interest to sailors who may have to tack up wind towards a waypoint.

Note: Without a destination (waypoint) selected, this page is of limited use. The current speed and heading will be displayed on the lower section of the screen, but the remainder of the page will be inactive.

The following diagram shows the information available on the Highway screen.

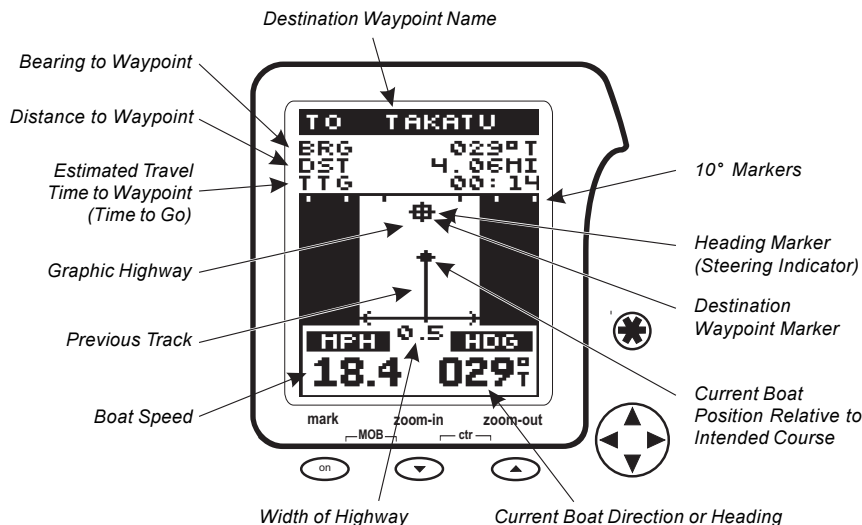

Your present position relative to your intended course is shown by the diamond in the center of the highway. Your present heading, relative to the current direction to the waypoint, is indicated by the cross that slides along the horizon, while the destination waypoint is represented by the stationary box in the center of the horizon.

If you deviate by more than 30° on either side of the waypoint, the heading marker will remain hard against the edge of the screen.

9.0 Fuel Screen

The TP240F has an extensive set of fuel management features. To utilize these features you need to purchase a Horizon fuel flow transducer, FT100. The FT100 plugs into the 5-pin connector on the back of the TP240F. For twin engine installations there is a Twin Engine Kit, TEK100. The TEK100 contains an additional fuel transducer and a 'Y' cable to enable both transducers to be connected to the 5-pin connector on the back of the TP240F (see diagrams in **Appendix C – TP240F Installation**).

The fuel flow transducer has been specifically developed for use with gasoline inboard and outboard engines. The fuel flow transducer best suited to outboards from 50 to 300hp and inboard engines from 70 to 450hp, but will operate outside these limits up to a maximum flow rate of 35 gallons (130 liters) per hour, per engine.

Note: Running the engine without the TP240F turned on will result in fuel use not being recorded. This will mean that the fuel remaining value will read higher than what is actually in the tank. Always turn your TP240F on immediately after starting your engine.

To display the Fuel screen, select the FUEL function from the Main Menu screen. Details of the Fuel screen are shown below.

The fuel used figure indicates the total volume of fuel that the engine or engines have consumed since last reset.

Highlight USED, then press ► to access reset and calibration functions.

FLOW indicates the averaged flow rate

SPEED indicates the boat's current speed

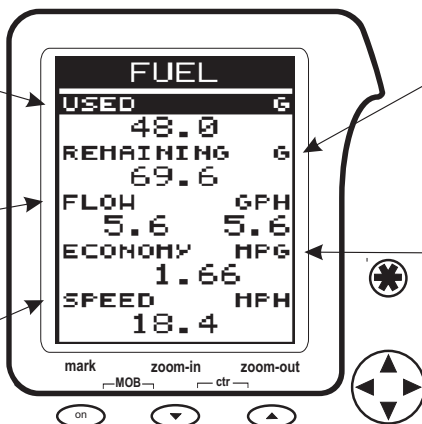

The fuel remaining amount is reduced as the fuel runs through the fuel transducer(s).

Highlight REMAINING, then press ► to change the value or set the low level alarm.

The ECONOMY reading can enable you to see the most fuel-efficient speed to travel at. This figure is calculated from the speed and flow rate.

Flow rate averaging

An engine does not draw fuel from the tank at a steady rate. Normally an engine will draw fuel at a relatively high rate for a few seconds until the carburetor bowl or fuel injection reservoir is full, and then the engine will not draw any fuel for a few seconds. If the instantaneous flow rate was displayed, it would be too erratic to follow on screen. To improve the display, the TP240F averages the fuel flow rate.

The amount of time over which the averaging is done can be changed in the Setup screen, see section **14.0 Setup**. The 'FLOW FLTR' (flow filter) value reflects the number of seconds over which the average is taken. Usually a value of 10-15 seconds will allow a satisfactory result for a carburetor engine. Fuel injected engines may require a larger value. Too high a flow filter value will slow down the display of real changes in flow rate when you change the throttle setting. This setting does not affect the fuel volume measurement, however it will affect the display of the flow rate.

Economy and speed

The speed error caused by Selective Availability increases significantly at low boat speeds. The fuel flow rate is not displayed for speeds of 5 knots or less. If the TP240F is receiving corrections from a differential receiver, the economy rate is displayed whenever the boat speed is above 1 knot.

Note: The TP240F indicates speed over ground, not speed through water like a speed/log instrument that uses a paddle wheel. If there is any tidal current, these two speed values will be slightly different.

9.1 Fuel used reset

This resets the fuel used figure to 000.0.

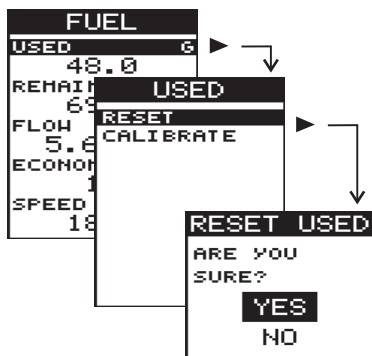

9.2 Fuel used calibration (Transducer calibration)

Without calibration, accuracy can be expected to be within a 10% tolerance. By recording the actual fuel usage of your boat over a period of time, it will be possible to adjust the TP240F to give consistently accurate readings within a 2% tolerance.

In a twin engine installation you must calibrate the port and starboard transducers independently.

To calibrate your fuel transducer you will need to accurately measure the fuel used. This is most easily done with a small portable tank. It should be noted that, due to air pockets, it is very difficult to fill under-floor tanks to the same level twice. At least 5 gallons (15 liters) should be used to ensure an accurate calibration. Each transducer in a twin engine installation must be calibrated. This may be done at the same time with two portable tanks, or at different times with one tank.

The procedure is as follows:

- 1) Reset the fuel used amount on the TP240F to 0.0
- 2) Connect the measurement tank(s) to the engine(s) via the fuel transducer(s).
- 3) Run the engine(s) at normal cruising speed until at least 5 gallons (15 liters) is indicated (10 gallons or 30 liters for twin engines).
- 4) Check the actual amount of fuel used per engine. The easiest way to do this is to refill the tank(s) to the original level(s) and record the value(s) shown on the fuel dispenser.
- 5) Select the fuel calibrate value. The amount that the TP240F has recorded is displayed. Use the cursor keys to enter the actual fuel amount used. Press ***** when the value is set. Confirm that you want to save the changes. (Repeat for other engine in twin engine installation).

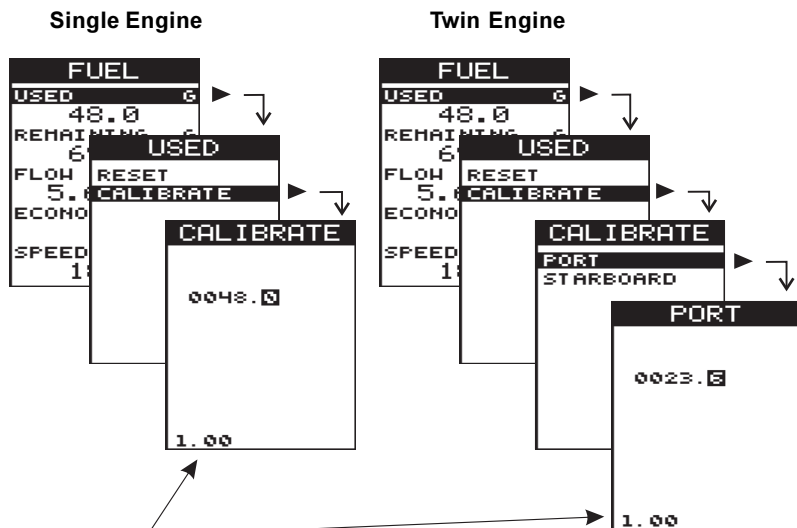

*This is an indication of the calibration factor.
It will be 1.00 as a default.*

9.3 Fuel remaining change

IMPORTANT: The fuel remaining value must be changed manually each time you change the amount of fuel in the tanks (e.g. filling, swapping or syphoning tanks). If it is not done, this figure will be misleading.

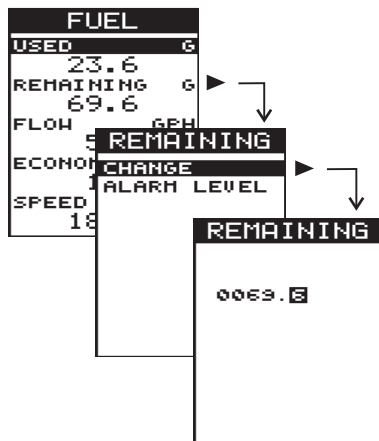

9.4 Fuel remaining low alarm

You can use this feature to warn you when your fuel remaining drops below a certain value. The value can be set from 1-9999. When the level drops below the value set, a message box saying "Fuel low alarm" will display, and the unit will beep until "OK" is selected. While the remaining amount is below the alarm amount, the alarm will re-activate whenever the unit is switched on, or the fuel remaining amount or low alarm value is changed. The fuel alarm may be totally disabled by setting the alarm value to 0.

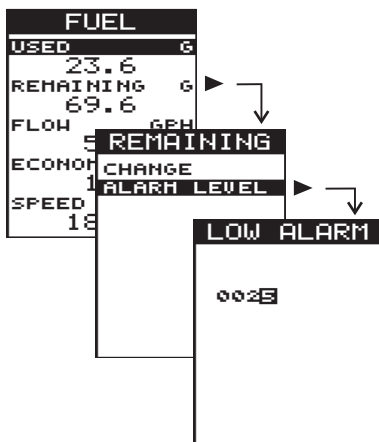

10.0 GoTo

The GoTo function provides a simple method of navigating from the current boat position to a waypoint or mark.

The GoTo sub-screen that can be selected from the Main Menu screen gives the options to GoTo a waypoint or mark, or to Go Along a route. Each of these options will bring up the appropriate list of destinations. Selecting a destination will start the navigation process and switch to the Highway screen. The TP240F will display the distance, time and bearing to the destination waypoint. It can also guide a NMEA compatible autopilot to the destination waypoint.

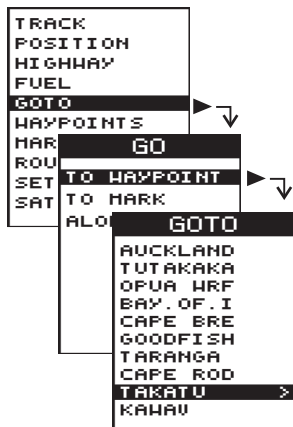

There are several other methods of activating the GoTo function:

- From the Track Plot screen, position the cursor over a waypoint or mark. Press and hold the **zoom-out** key until the waypoint or mark details are displayed. Select the GoTo option from this screen.



- From the Waypoints or Marks sub-screens, select your destination. A waypoint or mark details screen will be displayed. Select the GoTo option from this screen.
- From the Routes sub-screen, select the route you want to traverse. Then select the Go Along option.

Cancel GoTo

To deactivate the GoTo function simply select STOP NAV from the Main Menu screen. A message will be displayed asking you for confirmation that you wish to stop navigating to the current waypoint.

11.0 Waypoints

The GPS receiver of the TP240F provides current position, speed and direction information which can be viewed on the Position screen. But knowing your position is only a small part of navigation. You also need to keep track of where you have been and where you are going. Waypoints are electronic markers stored by the TP240F and are used to keep track of start points, destinations, objects of interest, and any other important position.

A waypoint is a named location with an associated latitude and longitude. You can GoTo waypoints and include them in routes. They can be moved, deleted or renamed. A choice of symbols are available for displaying them on the Track Plot screen.

11.1 Waypoints Screen

The Waypoints screen displays a list of waypoint functions. These functions allow you to create a new waypoint or select an existing waypoint to examine or change. A waypoint can be created by manually entering a lat/lon value or by saving the current boat position or by saving the position of the cursor in the Track Plot screen.



There are two methods of displaying the Waypoints screen.

Waypoints can be selected from the Main Menu screen. Alternatively, a short cut method of displaying the Waypoints screen is available. From the Track Plot screen, press and hold the **zoom-out** key until the Waypoints screen is displayed.

Note: *When using the short-cut method described above, the track plotter screen cursor must not be positioned over an existing waypoint. If the cursor is positioned over an existing waypoint, the shortcut will take you directly to a screen displaying the details for that particular waypoint.*

11.2 Creating Waypoints

The TP240F allows you to store and use up to 500 waypoints. There are three methods of creating new waypoints.

Creating a New Waypoint

You can create a new waypoint by directly entering a lat/lon value and waypoint name. To do this you must first display the Waypoints screen. The Waypoints screen can be selected from the Main Menu screen or entered directly from the Track Plot Screen by holding down the **zoom-out** key, as described previously.

From the list displayed in the Waypoints screen, select the NEW option. A new waypoint will be created and saved into memory, with a default lat/lon, symbol and a default name in the range WPT00001-WPT00500. A Waypoint Details screen, as shown below, will be displayed for the new waypoint. The options available from the screen are described later in this section. Select EDIT to enter the required lat/lon and optionally change the name and symbol.

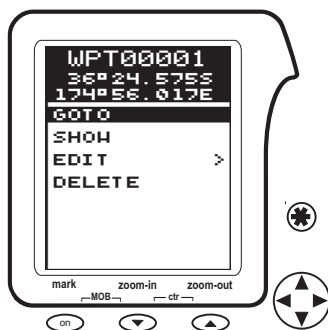

Note: When a new waypoint is created the TP240F will enter default values for the waypoint name and lat/lon. The lat/lon value will be the position of the cursor as displayed on the Track Plot screen. For this reason it is advisable to display the Track Plot screen and position the cursor near the location of the new waypoint. This will simplify the process of manually entering lat/lon values. The initial default values will be similar to the values you require.

Saving the current boat position

From the list displayed on the Waypoints screen, select the NEW AT BOAT option. A new waypoint will be created and saved into memory, with a default name in the range WPT00001- WPT00500, a default symbol and the boat's current latitude and longitude. A Waypoint Details screen will be displayed for the new waypoint. The options available from this screen are described later in this section. Select EDIT to change the name and/or symbol.

Saving the current cursor position

On the Track Plot screen move the cursor to the required location of the new waypoint. When the cursor is in the desired position for the new waypoint, press and hold the **zoom-out** key to display the Waypoints screen. Selecting the NEW AT CRSR option initiates an operation identical to NEW AT BOAT (see above), except that the current cursor lat/lon is used instead of the current boat lat/lon.

11.3 Viewing Waypoint Details

To view waypoint details you can select an existing waypoint from the list of waypoints. This option is available from the Waypoints screen, as described below. Alternatively, you can display waypoint details for a particular waypoint directly from the Track Plot screen. Position the cursor over the waypoint and press and hold the **zoom-out** key until the waypoint details appear on the display. Both methods are illustrated below.

From The Waypoints Screen.

1. Use the cursor keys to choose **SELECT** from the **Waypoints** screen.
2. Select the required waypoint from the list of waypoints.
3. The waypoint name and lat/lon will be displayed. To change waypoint information such as name, lat/lon or symbol, select the **EDIT** function from the list of available functions.

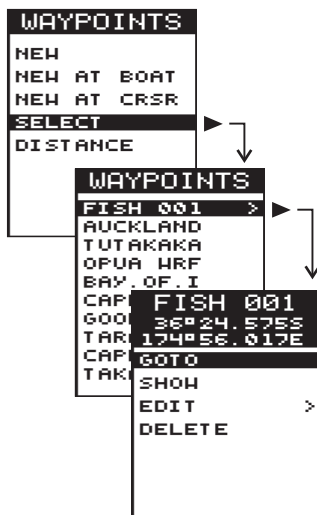

From The Track Plot Screen.

1. Use the cursor keys to position the Track Plotter cursor over the required waypoint. The waypoint name will appear in the top section of the Track Plotter display.



2. Press and hold the **zoom-out** key until the Waypoint Details are displayed.



3. The waypoint name and lat/lon will be displayed. To change waypoint information such as name, lat/lon or symbol, select the EDIT function from the list of available functions.



11.4 Changing Waypoint Details

To change the lat/lon value, waypoint name or waypoint symbol, display the Waypoint Edit screen by selecting EDIT from the Waypoint Details screen.

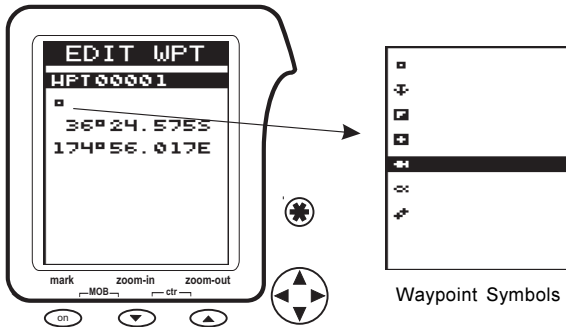

To edit the data on this page use the cursor keys to highlight the desired item and press the **▶** key to select it. Then use the **▲** and **▼** cursor keys to change the first character. These keys are used to scroll through the letters of the Alphabet and numbers 0-9. After the changes have been completed press the **▶** key to move to the next character or press the ***** key to

terminate editing of this data field. At the completion of all changes press ***** again and you will be prompted with a screen asking for confirmation to save the changes to memory. Select YES to save the changes to memory.

11.5 Displaying a Waypoint

If you are unsure of the location of an existing waypoint, you can use the Show function to display the waypoint in the center of the Track Plot screen. This allows you to see where it is in relation to other waypoints and the current boat position.

1. Display the Waypoint Details screen for the waypoint you wish to find by selecting it from the list of waypoints.



2. Use the cursor keys to select the SHOW function. The Track Plot screen will be displayed with the desired waypoint located in the center of the screen.

11.6 Deleting a Waypoint

1. To permanently delete a waypoint from memory, display the Waypoint Details screen for the waypoint you wish to delete, as described in section 11.3.



2. Use the cursor keys to select the DELETE function. The waypoint will be permanently removed from the TP240F memory.

Note: You can not delete an active waypoint.

11.7 Distance Calculations

The final waypoint function available is the distance and bearing calculator. The following diagram illustrates the method used to determine distance and bearing between waypoints.

1. Use the cursor keys to select DISTANCE from the Waypoints screen.
2. Select the start and end waypoints from the list of waypoints stored in memory
3. The Distance screen will be displayed, showing the distance and bearing from the start waypoint to the end waypoint.

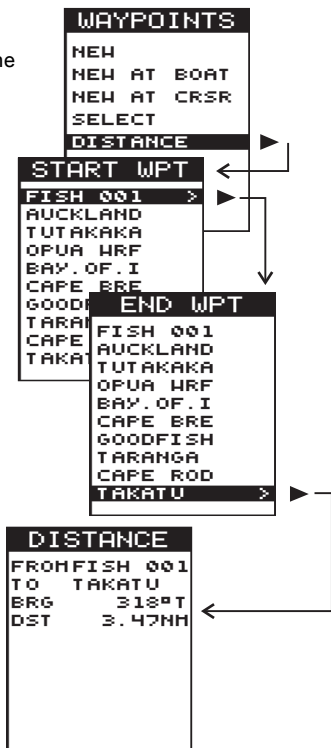

12.0 Marks

Marks are temporary waypoints. They are saved separately from waypoints, making them easier to find, change or delete. Marks are created by momentarily pressing the power on/off key. This will save the current boat position with a temporary name in the range of MARK0 to MARK9. Up to ten Marks can be saved in this manner. If more than ten Marks are created, the oldest ones will be overwritten by the more recent ones. There is a Mark Details screen in the same way as there is a Waypoint Details screen. The Mark Details screen can be displayed either by positioning the cursor over the mark on the Track Plot screen and holding down the **zoom-out** key, or by selecting the mark from the list displayed by the MARKS option on the Main Menu screen.

The symbol for a Mark is: 

12.1 Converting Marks to Waypoints

Marks can be converted to Waypoints by selecting the SAVE AS function from the Mark Details screen.

From The Track Plot Screen

1. Use the cursor keys to position the Track Plotter cursor over the required Mark. The Mark name will appear in the upper section of the Track Plotter display.



2. Press and hold the **zoom-out** key until the Mark Details screen is displayed.

zoom-out



3. Select **SAVE AS** from the list of available functions.



4. An edit screen will be displayed, allowing you to change the name of the waypoint and the waypoint symbol. Use the cursor keys to edit these.
5. Press  to save the changes to memory.



13.0 Routes



A route is a sequence of waypoints that are traversed in order. A route can consist of any number of waypoints from a minimum of two to a maximum of 20. Routes can be started from any waypoint within the route and can be traversed in either direction.

The Routes screen can be accessed from the Main Menu screen. The Routes screen has options for creating, editing and activating routes.

Note: While a route is active you can create new routes or edit other existing routes in memory. However, you can not edit or delete the current active route or any waypoints within the active route.

13.1 Creating a New Route

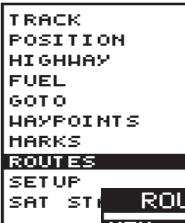
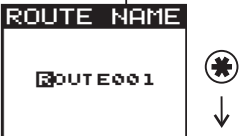
A route is created by selecting the waypoints in the route from those currently in memory.

1. Use the cursor keys to select **Routes** from the **Main Menu** screen.
2. Select **New** to create a new route. A default route name will be displayed. The cursor will be positioned on the route name allowing you to use the cursor keys to change the name, if required. Press the * key to save the route name to memory and to continue to the next step. A list of waypoints currently stored in memory will be displayed.
3. To select the first waypoint in the route, highlight it with the cursor keys and press the ► key. To continue to add further waypoints to the route see the following section titled **Adding and Deleting Waypoints in a Route**.

Press ► to select waypoint
4. To exit the routes screen and save the new route to memory, press the * key.

Creating a New Route

13.2 Adding and Deleting Waypoints in a Route

Waypoints within a route can be deleted and new waypoints can be added, providing the route is not currently active.

1. Choose **Select** to see the list of routes.
2. Select the route you wish to edit from the list.
3. Select the EDIT option.
4. The list of waypoints included in the route will be displayed. Move the cursor to the waypoint you wish to delete. Alternatively, if you wish to insert a new waypoint, move the cursor to the line above or below the point at which you wish to insert it. Press the ► cursor key to display the possible actions.

Examples of the two possible choices:

Insert Waypoint

You have the option of inserting the new waypoint either above the point you highlighted or below it.

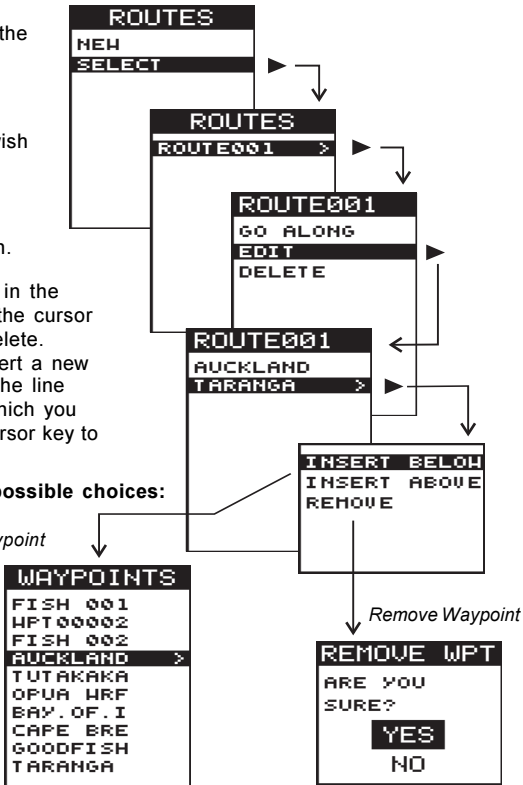

Adding and Deleting Waypoints in a Route

13.3 Starting and Canceling Routes

To start traversing a route, it must first be selected from the list of previously created routes. The route can be traversed in the forward direction or in the reverse direction, allowing you to return along the same route. You can also choose any waypoint in the route as the start waypoint.

Note: To cancel an active route select **STOP NAV** from the Main Menu screen. A message asking you to confirm that you wish to cancel the active route will be displayed.

1. Choose **Select** to see the list of routes.
2. Select the route from the list.
3. Select **Go Along** from the list of available functions.
 4. Choose whether to traverse the route in the forward direction or the reverse direction.
5. The list of waypoints included in the route will be displayed. Move the cursor to the first waypoint you wish to head towards. By default, the first waypoint in the route will be highlighted. Press the ► cursor key to start the route from the highlighted waypoint.

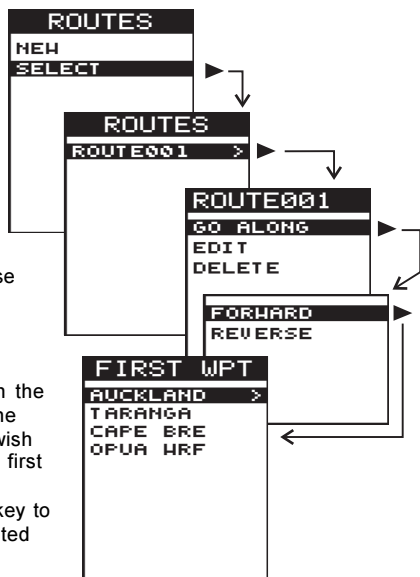

Starting a Route

13.4 Deleting a Route

The following sequence removes an existing route from memory.

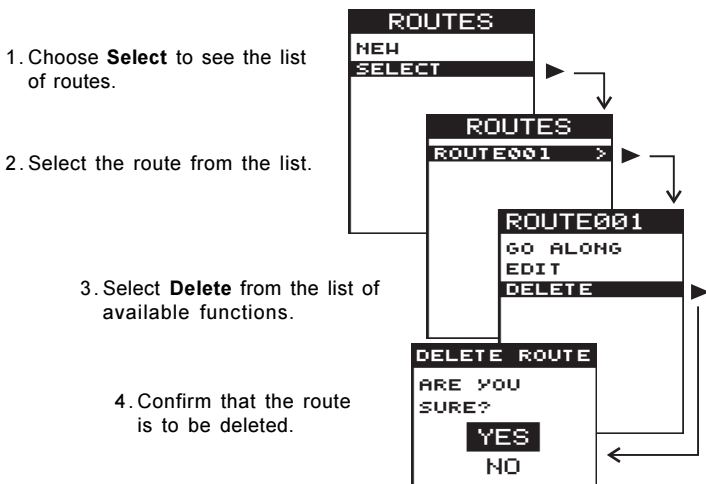

Deleting a Route

Note: You can not edit or delete an active route.

14.0 Setup

Select Setup from the Main Menu screen to access the TP240F setup functions. See section 5.0 for a detailed description of using the cursor keys to select menu items and changing data fields.

On the Setup screen and its sub-screens, where there is a value on the end of a highlighted menu line, this can be changed by pressing the ► or ◀ cursor keys. The ► key will step forward through the list of available values and the ◀ will step in the reverse direction.

| | |
|---------|--|
| TRACK | <p>TRACK CLEAR Clears the track of the boat from the Track Plot Screen. The TP240F will immediately start recording a new track if Track is enabled.</p> <p>TRACK ON/OFF MODE Enable/Disable saving of boat track. To obtain a track history, the TP240F saves the boat position to memory at regular intervals. These intervals can be time intervals or distance intervals. The MODE setting allows you to select time or distance intervals.</p> <p>INTRVL The selectable time interval range is 10 seconds to 1 hour. The selectable distance interval range is 0.1 to 5 miles/kilometers.</p> |
| HIGHWAY | Adjust width of the road. Range 0.1 to 5 miles/nautical miles/kilometers. |
| DATUM | <p>GPS derived positions are based on a worldwide reference (datum) known as WGS 1984. Many charts are based on datums other than WGS 1984. This results in an offset between a Lat/Lon plotted on the chart and the same Lat/Lon plotted on the TP240F. To match the TP240F with your chart you must enter the datum shown on the chart. Alternatively, if your datum is not included in the list of datums, you can enter an offset value to ensure the displayed lat/lon values match the chart. Once you have entered a datum or offset values for your chart, all latitudes and longitudes, including waypoints, will match the chart.</p> <p>USE This option allows you to set the TP240F to use either a datum or a position offset. The currently selected datum and position offset values are displayed in the bottom half of the screen. The selected correction method has a box drawn round it.</p> <p>POS.OFS. > Position Offset edit window. Enter offset values in the range 0.000 – 9.999 minutes.</p> <p>DATUM > Select this option to choose from the list of 106 available chart datums.</p> |

| | | |
|----------|---|---|
| BEARINGS | The TP240F automatically calculates the magnetic variation for the location in which it is situated. Consequently, all bearings and course directions can be displayed either relative to true North or magnetic North. Select TRU or MAG as required. | |
| UNITS | The TP240F has three units of measure; Nautical miles, Statute (land) miles and Kilometers. This setting applies to all distance and speed readings displayed on the TP240F. | |
| TIME | OFFSET | This is the time offset from your time zone to Greenwich Mean Time (GMT). Range +/- 13 hours in steps of 30 minutes. |
| | 12/24HR | Sets the time display to be in either 12 hour or 24 hour format. |
| FUEL | ENGINES | Choose the number of gasoline engines, 1 or 2. |
| | VOL UNIT | Select the unit of measure for volume; liters, Imperial gallons, or U.S. gallons. |
| | FLOW FLTR | Adjust the amount of averaging of the fuel flow rate. Range 1–60 seconds. |
| DISPLAY | CONTRAST | Display Contrast. This adjustment enables you to obtain the optimum display appearance. Set the level for optimum display contrast. Range 0–10. |
| | BACKLIGHT | Display backlight intensity. Range 0–15. |
| SIMULATE | Simulation mode provides a method of becoming familiar with the TP240F functions. Boat movement is simulated and all navigation functions are available. Setting SIMULATE to ON generates a simulated boat with an initial position at the current position of the Track Plot screen cursor, with zero speed and heading. To change the speed and heading, switch to the Highway screen and use the cursor up and down keys to change speed, and left and right to change the boat's heading. | |

15.0 Chart Datums

GPS derived positions are based on a worldwide reference (datum) known as WGS 1984. Many charts are based on datums other than WGS 1984. This results in an offset between a Lat/Lon plotted on the chart and the same Lat/Lon plotted on the TP240F. To match the TP240F with your chart you must enter the datum specified on the chart. See section **14.0 Setup** for details on how to select a chart datum. Once your local datum has been entered, all latitudes and longitudes, including waypoints, will match the chart.

Note: When using a number of charts with different datums it is important to ensure that you change the datum to match the chart currently being used. If the destination waypoint is on a different chart, be sure to change to that chart's datum before entering the latitude and longitude of the destination waypoint.

Alternatively, you can manually enter a lat/lon offset value to bring the displayed lat/lon values in line with the chart you are using. See the Setup screen for details on how to enter a lat/lon offset. The lat/lon offset function is typically used to match the TP240F with older charts where an island may have a large position error, but all points around the island have the same error.

| Tracker abbreviation | Datum name | Datum code | Locality |
|----------------------|--------------------------|------------|---|
| ADINAN | Adindan | ADI-M | Ethiopia, Sudan |
| AFGOOYE | AFGOOYE | AFG | Somalia |
| AINELABD70 | AIN EL ABD 1970 | AIN-A | Bahrain Island |
| AMRICN SAMOA | American Samoa 1962 | AMA | American Samoa Islands |
| ANNA 1 AST65 | Anna 1 Astro 1965 | ANO | Cocos Islands |
| ANTIGUA | Antigua | AIA | Leeward Islands |
| ARC 1950 | ARC 1950 | ARF-M | Botswana, Lesotho, Malawi, Swaziland, Zaire, Zambia, Zimbabwe |
| ARC 1960 | ARC 1960 | ARS-M | Kenya, Tanzania |
| ASCN IS 1958 | Ascension Island 1958 | ASC | Atlantic Ocean |
| ASTRO BCN"E" | Astro Beacon E | ATF | Iwo Jima |
| ASTRODOS71/4 | Astro DOS 71/4 | SHB | St. Helena Island |
| ASTR STN1952 | Astronomic Station 1952 | ASQ | Marcus Island |
| AUST.GEO1966 | Australian Geodetic 1966 | AUA | Australia and Tasmania |
| AUST.GEO1984 | Australian Geodetic 1984 | AUG | Australia and Tasmania |
| AYABELLE | Ayabelle Lighthouse | PHA | Djibouti |
| BELLEVUE | Bellevue (IGN) | IBE | Efate & Erromango Islands (Vanuatu) |
| BERMUDA 1957 | Bermuda 1957 | BER | Bermuda Islands |
| BOGATA | Bogota Observatory | BOO | Colombia |
| CAMPO INCH | Campo Inchauspe | CAI | Argentina |
| CANTON AST66 | Canton Island 1966 | CAO | Phoenix Islands |
| CAPE CANAV | Cape Canaveral | CAC | Florida, Bahamas |
| CAPE | Cape Province | CAP | South Africa |
| CARTHAGE | Carthage | CGE | Tunisia |
| CHATHAM 1971 | Chatham 1971 | CHI | New Zealand |
| CHUA ASTRO | Chua Astro | CHU | Paraguay |

| Tracker abbreviation | Datum name | Datum code | Locality |
|-----------------------------|--------------------------------|-------------------|--|
| CORREGO ALEG | Corrego Alegre | COA | Brazil |
| DJAKARTA | Djakarta (Batavia) | BAT | Sumatra (Indonesia) |
| DOS 1968 | DOS 1968 | GIZ | Gizo Island (New Georgia Islands) |
| EASTER IS 67 | Easter Island 1967 | EAS | Easter Island |
| EURO 1950 | European 1950 | EUR-M | |
| EURO 50 ENGL | European 1950 England | EUR-G | England, Channel Islands, Scotland, Shetland Islands |
| EURO 50 WEST | European 1950 Western | EUR-A | Austria, Denmark, France, Netherlands, Switzerland |
| EURO 1979 | European 1979 | EUS | |
| GAN 1970 | GAN 1970 | GAA | Republic of Maldives |
| GEO DAT 1949 | Geodetic Datum 1949 | GEO | New Zealand |
| GRACIOSA1948 | Graciosa Base SW 1948 | GRA | Faial, Graciosa, Pico, Sao Jorge, Azores |
| GUAM 1963 | Guam 1963 | GUA | Guam |
| GUX 1 ASTRO | GUX 1 Astro | DOB | Guadalcanal Island |
| HJORSEY 1955 | Hjorsey 1955 | HJO | Iceland |
| HONG KONG 63 | Hong Kong 1963 | HKD | Hong Kong |
| HU-TZU-SHAN | HU-TZU-SHAN | HTN | Taiwan |
| IND BNGLDSH | Indian | IND-B | Bangladesh |
| INDIAN 1975 | Indian 1975 | INH-A | Thailand |
| INDONESIA 74 | INDONESIA 74 | IDN | Indonesia |
| IRELAND 1965 | Ireland 1965 | IRL | Ireland |
| ISTS 073ASTR | ISTS 073 Astro 1969 | IST | Diego Garcia |
| JOHNSTON IS | Johnston Island 1961 | JOH | Johnston Island |
| KANDAWALA | Kandawala | KAN | Sri Lanka |
| KERGUELEN IS | Kerguelen Island | KEG | Kerguelen Island |
| KERTAU 1948 | Kertau 1948 | KEA | West Malaysia, Singapore |
| KUSAE ASTRO | Kusaie Astro 1951 | KUS | Caroline Islands, Federated States of Micronesia |
| L.C.5 ASTRO | L.C. 5 Astro | LCF | Cayman Brac Island |
| LIBERIA 1964 | Liberia 1964 | LIB | Africa |
| LUZON PHILIP | Luzon | LUZ-A | Phillippines (excluding Mindanao Island) |
| LUZON MINDAN | Luzon Mindanao Island | LUZ-B | Mindanao Island |
| MAHE 1971 | Mahe 1971 | MIK | Mahe Island |
| MASSAWA | Massawa | MAS | Ethiopia |
| MERCHICH | Merchich | MER | Morroco |
| MIDWAY AST61 | Midway Astro 1961 | MID | Midway Islands |
| MINNA NIG | Minna | MIN-B | Nigeria |
| NHRWN MASI | Nahrwan | NAH-A | Masirah Island (Oman) |
| NHRWN SAUDI | Nahrwan | NAH-C | Saudia Arabia |
| NHRWN U.A.E. | Nahrwan | NAH-B | United Arab Emirates |
| NAPARIMA BWI | Naparima, BWI | NAP | Trinidad & Tobago |
| NAD27 ALASKA | North American 1927 Alaska | NAS-D | Excluding Aleutian Islands |
| NAD27 BAHAMA | North American 1927 Bahamas | NAS-Q | Excluding San Salvador Island |
| NAD27 CANADA | North American 1927 Canada | NAS-E | |
| NAD27 CANALZ | North American 1927 Canal Zone | NAS-O | |
| NAD27 CARIBN | North American 1927 Caribbean | NAS-P | |

| Tracker abbreviation | Datum name | Datum code | Locality |
|-----------------------------|---|-------------------|---|
| NAD27 CENTRL | North American 1927 Central America | NAS-N | Belize, Costa Rica, El Salvador, Guatemala, Honduras, Nicaragua |
| NAD27 CONUS | North American 1927 Conus | NAS-C | |
| NAD27 CUBA | North American 1927 Cuba | NAS-T | |
| NAD27 GREEN | North American 1927 Greenland | NAS-U | (Hayes Peninsula) |
| NAD27 MEXICO | North American 1927 Mexico | NAS-L | |
| NAD27 SANSAL | North American 1927 San Salvador Island | NAS-R | |
| NAD83 | North American 1983 | NAR | |
| NTH SAHARA59 | North Sahara 1959 | NSD | Algeria |
| OBSERV 1966 | Observatorio 1966 | FLO | Corvo and Flores Islands (Azores) |
| OLD EGYPT**07 | Old Egyptian 1907 | OEG | Egypt |
| OLD HAWAIIAN | Old Hawaiian | OHA-M | Hawaii |
| OMAN | Oman | FAH | Oman |
| ORDSRVY GB | Ordinance Survey of Great Britain | OGB-M | England, Isle of Man, Scotland, Shetland Islands, Wales |
| PICODELASNV | Pico de las Nieves | PLN | Canary Islands |
| PITCAIRN1967 | Pitcairn Astro 1967 | PIT | Pitcairn Island |
| PORTO SANTO | Porto Santo 1936 | POS | Porto Santo & Madeira Islands |
| PROV S AM 56 | Provisional South American 1956 | PRP-M | Bolivia, Chile, Colombia, Ecuador, Guyana, Peru, Venezuela |
| PROV S CH 63 | Provisional South Chilean 1963 | HIT | Southern Chile |
| PUERTO RICO | Puerto Rico | PUR | Puerto Rico, Virgin Islands |
| QATAR NAT | Qatar National | FAH | Qatar |
| QORNOQ | Qornoq | QUO | South Greenland |
| REUNION | Reunion | REU | Mascarene Islands |
| ROME 1940 | Rome 1940 | MOD | Sardinia (Sardegna Island) |
| SANTO DOS | Santo (DOS) | SAE | Espírito Santo Island |
| SAO BRAZ | Sao Braz | SAO | Sao Miguel, Santa Maria Islands (Azores) |
| SAPP.HILL 43 | Sapper Hill 1943 | SAP | East Falkland Island |
| SCHWARZECK | Schwarzeck | SCK | Namibia |
| S AMERICA 69 | South American 1969 | SAN-M | Argentina, Bolivia, Brazil, Chile |
| SOUTH ASIA | South Asia | SOA | Singapore |
| TIMBALAI1948 | Timbalai 1948 | TIL | Brunei, East Malaysia |
| TOKYO | Tokyo | TOY-M | Japan, Okinawa, South Korea |
| TRISTAN 1968 | Tristan Astro 1968 | TDC | Tristan da Cunha |
| VIT LEVU1916 | Viti Levu 1916 | MVS | Viti Levu Island (Fiji Islands) |
| WAKE IS ASTR | Wake Island Astro 1952 | WAK | Wake Atoll |
| WAKE-ENIWET | Wake-Eniwetok 1960 | ENW | Marshall Island |
| WGS84 | WGS-84 | | |
| ZANDERIJ | Zanderij | ZAN | Suriname |

Appendix A – Specifications

TP240F General Specifications

- **Dimensions**
5.9" H x 5.2" W x 3.5" D.
- **Display Type**
STN temperature compensated LCD.
- **Display Matrix**
100 x 64 Pixels.
- **Input Voltage**
11 to 16.6 Volts DC.
- **Backlighting**
15 levels plus off, 5 levels plus off directly available from * key.
- **Operating Temperature**
0 °C to 50 °C ambient (32 °F to 122 °F).
- **Display Scales**
Distance - 0.1 to 500 nautical miles/miles/kilometers.
- **Waypoints**
500 plus 10 marks.
- **Routes**
20 reversible of up to 20 waypoints each.
- **Chart Datums**
106 Datums plus User Adjustable Offset.
- **Navigation Method**
Rumb line with perpendicular finishing line termination.
Maximum Latitude: 75° N or S.
- **NMEA0183 V2.1 Output**
APB, BWR, GLL, RMC, VTG, XTE.
- **DGPS Input**
RTCM 104, 9600 baud, NMEA 0183 or RS232 signal levels.
- **Power Use**
100mA Typical (Backlight off), 125mA (Backlight on), plus 25mA per fuel transducer.

TP240F Fuel Functions

- **Volume Units**
Liters, Imperial gallons or US gallons.
- **Engine Types**
Outboard gasoline engines 50 to 300hp.
Inboard gasoline engines 70 to 450hp.
- **Number of Engines**
One or two.
- **Maximum Fuel Flow Rate**
35 US gallons per hour per engine; or 130 liters per hour per engine.
- **Fuel Used and Fuel Remaining Indication**
0.0 to 9999.9 liters or gallons.
- **Fuel Flow Rate Indication**
0.0 to 35.0 US gallons per hour, or 0.0 to 130.0 liters per hour.
- **Economy Rate Indication**
0.00 to 99.99 distance units per volume unit.



Appendix B – Replacement Parts

| | Part Number |
|------------------------------|--------------------|
| Mounting Bracket | 160006020A |
| Mounting Bracker Knobs | 154003016A |
| Swivel Mount..... | 106667020A |
| Mounting Bracker Kit | 602008011A |
| Rubber Washers | 581004030A |
| Power Cord | YL0002021A |

Appendix C – TP240F Installation

Packing List

- GPS TP240F Display Head, including 2 mounting knobs & 2 washers
- Power/data cable
- Mounting Bracket
- User's manual

Mounting

Choose a location for the display head that provides good visibility and protects the unit from direct sun and excessive exposure to water.

Select a position that is:

- At least 12" from a compass
- At least 12" from any radio
- At least 5 feet from any radio antenna
- Easy to read by the helmsman and crew
- Protected from physical damage
- Accessible for electrical cable connections
- Must have a clear view of the sky, but can "see" through glass, perspex, fibreglass and fabric.

Once a location is selected secure the mounting bracket with the screws provided in the mounting kit.

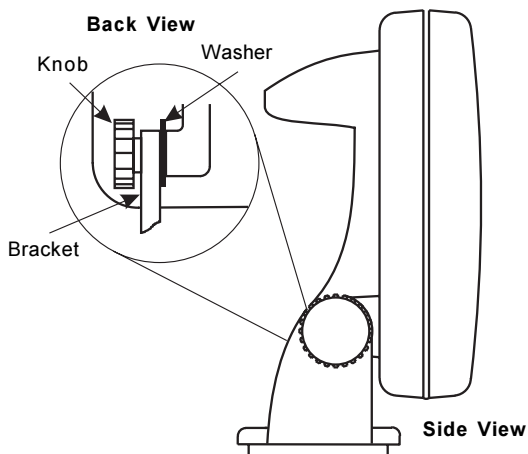

Connecting Display Head to Bracket

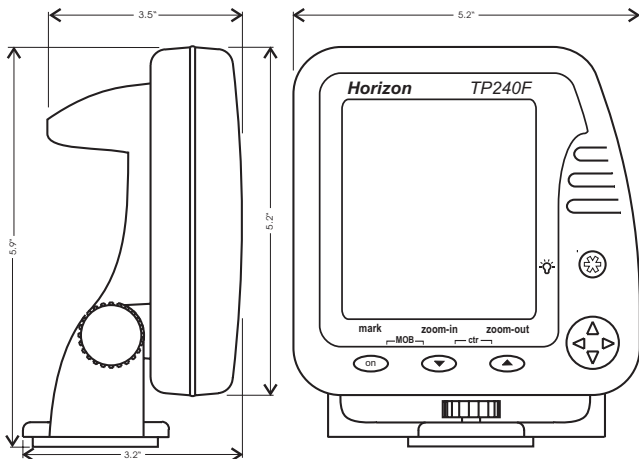

Power Cable Connections

1. Connect the red wire to the positive supply (11-16.6 VDC) via a 1 amp fuse or 1 amp circuit breaker. Connect the cable shield to the negative supply. If possible, route the antenna and power cable away from other wiring on the boat. Electrical noise from engine wiring, bilge pumps and other equipment can affect the display.
2. Insert the display head, rubber washers and mounting knobs in to the mounting bracket. The rubber washers are located between the bracket and the case of the display head. See diagram.

Five Pin Connector

The five pin connector is used for the fuel transducer. A twin engine fuel kit contains a 'Y' cable to allow two fuel transducers to be connected.

Power/Data Cable Connections

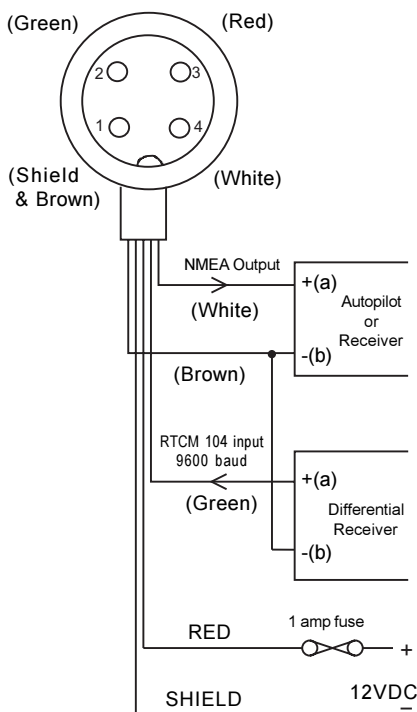

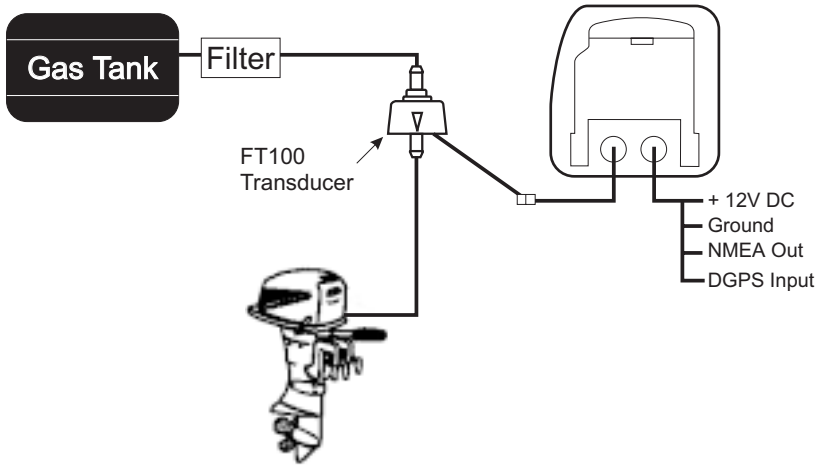

Single Engine Installation

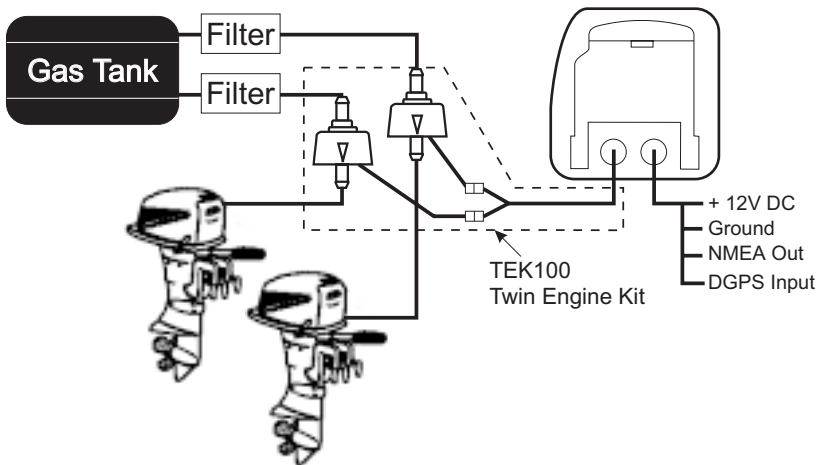

Twin Engine Installation

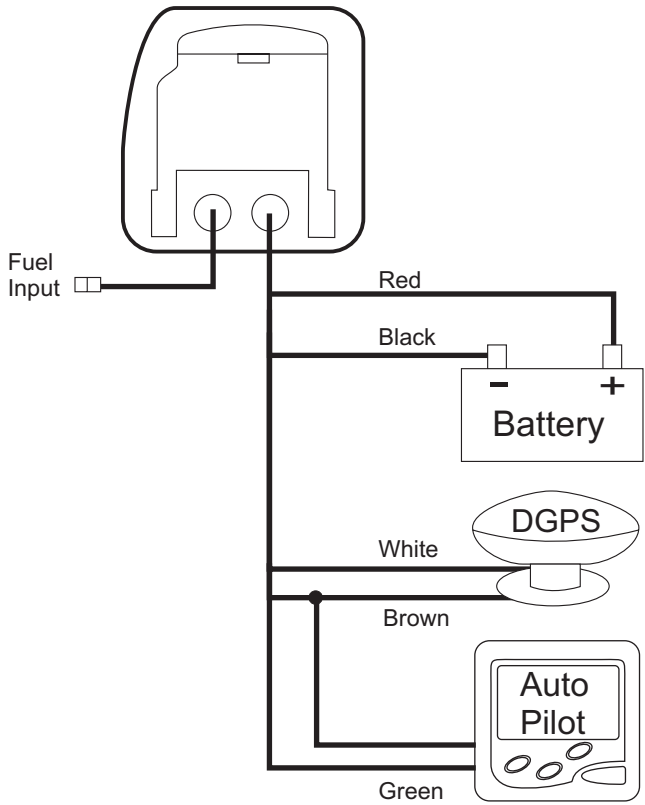

Appendix D – Trouble Shooting Guide

| PROBLEM | CAUSE – SOLUTION |
|---|---|
| TP240F will not power on. | Power/data cable not connected or not fully connected into its socket. Power supply connections reversed. |
| TP240F switches itself off. | Check for a poor connection in the power cable causing intermittent loss of power. When the TP240F detects a large supply voltage surge, it will turn itself off to protect itself. Check for loose battery connections. |
| Units beeps when powered on, but screen shows nothing or is too faint to read. | The contrast has been set too low. Switch the unit off by holding the power key for at least 3 seconds. (Alternatively, if unsure whether the unit is on or off, unplug the power connector for at least 1 second). Hold down the right cursor key (make sure only the right key, not up or down as well). Then press the power key until the buzzer sounds continuously, then release both keys. The contrast will be set to 5 and the backlighting to 15. |
| Some previously available navigation functions are no longer available. 'GPS FIX LOST' message displayed. | GPS no longer has a fix. This may occur occasionally if the antenna does not have a clear view of the sky. The satellite positions are constantly changing so that their signals can come from any direction. It is essential that the antenna has a clear view of the sky. |
| Prolonged period to obtain a fix. | This will occur if the TP240F has been moved more than 300 miles (500 km) since it was last switched on, or if it has not been used for several months. The TP240F will automatically 'search' the sky for all available satellites. This may take a few minutes. This function is fully automatic and requires no user intervention. Subsequent times to first fix should typically be 45 seconds. |
| Position indicated on TP240F varies by up to 100 meters from true position. | The USA Department of Defense introduced a varying offset known as Selective Availability (SA). The direction and magnitude of the offset is constantly varying. SA will cause errors typically of 0-100 meters, but can occasionally cause errors in excess of 300 meters. The effects of SA can be reduced with the installation of a differential receiver, if this service is available in your area. |
| Indicated speed does not match the boat's speed/log instrument. | The constantly changing SA offset results in an indicated speed error that is normally less than 1 knot, but occasionally exceeds 1.5 knots. A TP240F connected to a differential receiver will not exhibit this error. The TP240F indicates speed over the sea bed. A speed/log instrument indicates speed through the water. If there is any tidal current, these two will be different. Speed/log instruments are often not calibrated accurately and do not accurately show the boat's speed. |

| | |
|---|---|
| <p>Indicated heading does not match the boat's compass.</p> | <p>The boat must be moving before the TP240F can determine its direction. The TP240F BEARINGS setting must be set to MAG before the indicated heading will match the compass. The constantly changing SA offset results in an indicated heading error, usually apparent only at low speeds. The TP240F indicates the boat's direction of movement over the sea bed. External influences such as tidal currents and wind induced leeway mean that this may not be the same direction that the boat is pointing in, which is what a compass indicates. The TP240F is not influenced by magnetic materials like a compass.</p> |
| <p>No/low fuel flow indicated.</p> | <p>Check that the 5 pin fuel transducer connector is fully inserted into its socket on the back of the TP240F. Check that the fuel filter(s) in the line are clean. Ensure that the fuel flow transducer has not been exposed to excessive heat or vibration.</p> |
| <p>Erratic fuel flow readings.</p> | <p>The mounting position of the fuel flow transducer must not be too close to the fuel pump(s) and not subject to excess vibration. Check for air leaks in the fuel hose(s) or fuel pick-up(s) in the tank(s). The filtering level (averaging) has not been set to suit the engine(s). In the Fuel sub-screen under Setup, increase the FLOW FLTR value until a steady flow rate is indicated. Check the fuel flow readings are not zero.</p> |
| <p>No fuel economy reading.</p> | <p>For the TP240F to be able to calculate an economy reading, the boat must be travelling above 5 knots, or above 1 knot if a differential receiver is in use.</p> |
| <p>Fuel Remaining does not match the amount left in the tank.</p> | <p>Fuel Remaining must be set to the amount of fuel on board after every refueling. Engine has been run without the TP240F turned on to record the fuel usage. Fuel transducer calibration is required when the TP240F is first installed.</p> |



1950701A

Standard Communications Corp.
P.O. Box 92151
Los Angeles, CA 90009-2151
Telephone 310/532-5300

© STANDARD COMMUNICATIONS CORP. 1997
ALL RIGHTS RESERVED
PRINTED IN NEW ZEALAND
APRIL 1999

MA00009-00



Addendum to TP240F Owner's Manual

New feature – Center on boat / follow boat.

Once the -ctr- key combination (simultaneous press of zoom-in and zoom-out) is pressed the track plot screen will follow the boat until the mode is "unlocked". Unlocking is by panning the track plot screen (when the cursor gets to the edge of the screen), or zooming in until the boat moves outside the central area of the screen. Activation of the centre on boat mode feature is indicated by a small hollow boat diamond between the speed and heading on the bottom line of the track screen.

Note: This feature will be activated by default on power up and may be activated from anywhere, not only the track screen, compared with the earlier center feature noted on P7 of the manual. The unit will switch to the track plot screen whenever the -ctr- key combination is pressed.

New feature – 3 Configurable alarms

The highway width is no longer changed in the setup menu as indicated on P31 of the manual. This setting has been replaced with an "ALARM" menu with settings for 3 alarms.

1) Highway XTE alarm.

When the setting "HIGHWAY" is turned on, the XTE (Cross track error) is continually monitored while navigating to a waypoint. If the boat moves outside the selected highway screen road width, an alarm prompt will be shown, and the buzzer will sound.

Notes: 1) The alarm will reactivate every time the boat moves inside the highway screen road width, then strays outside it again. 2) The highway screen does not have to be showing for the alarm to activate.

2) 1 MINUTE alarm

When the setting "1 MINUTE" is turned on, the TTG (Time to go) is continually monitored while navigating to a waypoint (during navigation of a route, the setting is active for each waypoint in the route). The first time that the TTG drops below 1 minute, an alarm prompt will be shown, and the buzzer will sound.

Note: The alarm will not reactivate if the TTG raises above 1 minute, then drops below 1 minute again.

3) Anchor drag alarm.

When the setting "ANCHOR" is turned on, the change in position is continually monitored. If the boat moves a distance greater than that set by "ANCHOR 0.xx" from the boat's position when "ANCHOR SET >" was activated, an alarm prompt will be shown, and the buzzer will sound.

Notes: 1) The alarm will reactivate every time the boat moves inside the anchor circle, then strays outside it again. 2) Without DGPS (Differential GPS), selective availability may cause the reported position to deviate by up to 900 feet. This will trip the anchor alarm, the distance of "ANCHOR 0.xx" may need to be increased.

New feature - Distance log.

The position screen as pictured on P13 of the manual now also displays distance travelled since last cleared. This works by measuring a succession of straight lines (similar to the track drawing). This means that it will not be highly

accurate if you drive around in small circles (e.g. 600ft) all day. However, if you forget to turn the unit on at the start of the journey, you will still get a good approximation of the distance from the position where the unit last had a fix. The distance units setting as indicated on P32 of the manual has been replaced by a distance menu, which allows clearing of the distance log and setting of the distance units.

New feature – User configurable waypoint display.

New options have been added to enhance the display of waypoints on the track screen.

On the waypoint edit screen (see P23 of the manual), two extra settings have been added: "NAME | ON/OFF" and "SYMBOL | ON/OFF". By default, when a new waypoint is created, only the symbol will be shown on the track screen. Turning the name display on will cause the waypoint's name to be displayed to the right of the waypoint on the track screen. Turning the symbol display off will prevent the waypoint from being shown on the track screen.

Note: 1) Turning the symbol off does not delete the waypoint. The waypoint can simply be selected from the waypoint list and the symbol turned back on again. 2) You cannot have the waypoint name turned on, and the waypoint symbol turned off.

On the main waypoint menu (see P20 of the manual), two extra settings have been added. "NAMES | ALL/NONE/SEL." and "SYMBOLS | ALL/NONE/SEL." When SEL. (short for SELECTED) is chosen the name/symbol will be displayed according to each individual waypoint setting. When ALL is chosen, the name/symbol will be displayed regardless of each waypoint setting. When NONE is chosen, the name/symbol will not be displayed regardless of each waypoint setting.

Note: You cannot have the waypoint names turned on, and the waypoint symbols turned off.

New feature – Goto key.

Holding the zoom-in key, while any screen is showing, will take you immediately to the GO, TO WAYPOINT, TO MARK, ALONG ROUTE screen as shown on P19 of the manual.

Note: If you are already navigating to a waypoint, an option will first be presented asking whether you want to cancel that navigation first.

New feature – Waypoint key.

Holding the zoom-out key, while any screen is showing, will take you immediately to the WAYPOINTS menu as shown on P20-24 of the manual.

Note: While the track plot screen is showing, and the cursor is positioned immediately over a waypoint, the shortcut will take you directly to the screen for that particular waypoint.

Change in operation – highway width.

The highway width is no longer changed in the setup menu as indicated on P31 of the manual.

The zoom-in and zoom-out keys will alter the highway width when the highway screen is displayed.