

# West Marine



266827

## **MARINE PRODUCTS LIMITED WARRANTY**

West Marine Product's warrants to the original purchaser only, that each new instrument will be free from defects in materials and workmanship under conditions of normal use and service for a period of one(1) year from the date of delivery to the Purchaser. West Marine Product's liability under this warranty shall be limited to repair or replacement of the defective product, at West Marine Product's option, and under no circumstances shall West Marine Product's be liable for consequential, incidental, or other damages arising out of, or in any way connected with a failure of the product to perform as set forth herein.

THIS LIMITED WARRANTY EXTENDS ONLY TO THE PURCHASER AND IS IN LIEU OF ALL OTHER EXPRESS OR IMPLIED WARRANTIES, INCLUDING THOSE OF MERCHANTABILITY AND FITNESS FOR A PARTICULAR PURPOSE.

In the event of a defect, malfunction, or failure of the product to conform to specifications during the one-year warranty period, West Marine Product's will repair or replace, at its option and without charge to the Purchaser, the product which upon examination by West Marine Product's shall appear to be defective or not up to factory specifications. West Marine Product's will pay all labour charges incurred in providing such warranty service. To obtain warranty service, the defective product must be returned to West Marine Product's together with proof of the date of purchase. The Purchaser must pay any transportation expenses in returning the product to West Marine Product's. West Marine Product's will examine the product and respond to the Purchaser in approximately four(4) weeks from date of receipt of the product claimed to be defective.

This limited warranty does not extend to any product which has been subjected to misuse, neglect, accident, improper installation, or subject to use in violation of the maintenance or operating instructions, if any, furnished by West Marine Product's; nor does this warranty extend to products on which the serial number has been removed, defaced, or changed. West Marine Product's reserves the right to make changes or improvements to its products during subsequent production without incurring the obligation to install such changes or improvements on previously manufactured or sold products.

Some states do not allow limitations on the duration of the warranty or exclusions or limitations of incidental or consequential damages so these eliminations or exclusions may not apply to you. This warranty gives you specific legal rights which vary from state to state.

# Contents

<b>Specifications</b> .....	<b>2</b>
<b>Installation</b> .....	<b>3</b>
Location .....	3
Mounting .....	3
Wiring Connection .....	4
Multiple Instruments .....	4
<b>Operation</b> .....	<b>5</b>
Function Select Keys .....	5
Backlighting On / Off .....	5
Select Temperature Units .....	5
Select Speed Units .....	6
Reset Average Speed, Maximum Speed and Log .....	6
Reset Total Log .....	6
Trend Indicator .....	6
Elapsed Timer .....	7
Count Down Timers .....	7
<b>Secondary Functions</b> .....	<b>8</b>
Calibrate Temperature Display .....	9
Simulation Mode .....	9
<b>Speed Calibration</b> .....	<b>10</b>
Speed Comparison Method .....	10
Log Calibration Method .....	10
<b>Troubleshooting Chart</b> .....	<b>11</b>

## Specifications

- Power supply**  
 10.7 to 16.6 VDC 10 mA nominal, 30 mA with backlight on.
- Operating temperature**  
 0°C to 45°C.
- Size of display**  
 112 x 112 x 24mm (4.4 x 4.4 x 1") , overall depth 35mm (1.4") behind panel.
- Display type.**  
 Twisted Nematic (TN) grey background, 0°C to +70°C.
- Illumination**  
 Red LED switchable from key pad.
- RF interference**  
 Less than 6 dB maximum quieting on any marine radio channel with 3 dB gain antenna within 1 meter of instrument display head (European EC specifications).
- Boat speed**  
 0 to 50 knots (depending on transducer type). User selectable to display in 0.1 or 0.01 increments.
- Speed units and resolution**  
 0.0 to 19.9 and then 20 to 50 in knots, MPH or KPH.
- Average speed**  
 Unit selectable to 50 knots, resets to zero via key pad or at power down.
- Maximum speed**  
 Records max. speed to 50 knots. Reset to zero via key pad or at power down.
- Trip log**  
 0 to 1999 units key pad resettable.
- Total log**  
 0 to 1999 units key pad resettable.
- Timers**  
 5 and 10 minute count down timers with audible alarms, 0 to 19:59 hours count up elapsed time.
- Sea temperature**  
 0.0°C to 37.7°C (32.0°F to 99.9°F) 10Kohm at 25°C. Tenths of a degree are displayed.
- Sea temperature sensor type**  
 10k ohm NTC at 25°C (77°F).
- NMEA Outputs**  
 The S100 outputs the following NMEA0183 data sentences; DBT, VHW, VLW, MTW, PTTK.

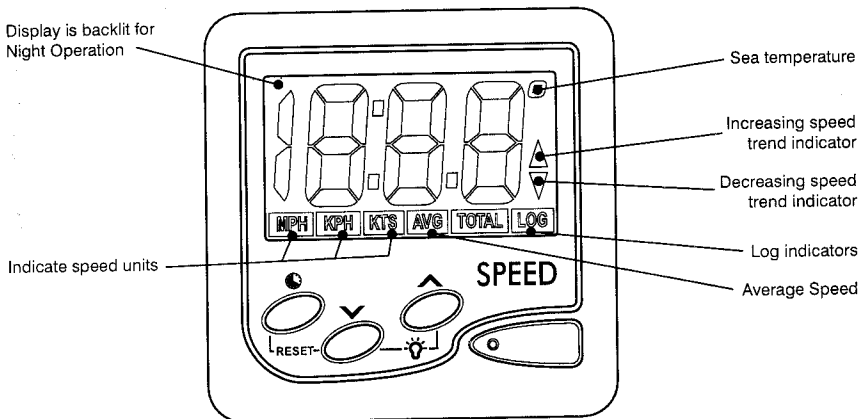

# Installation

## Location

The S100 is designed for above or below deck installation. Select a position that is:

- At least 300mm from a compass
- At least 500mm from any radio
- Easy to read by the helmsman and crew
- Protected from physical damage
- Accessible to electrical cable connections

## Mounting

The mounting surface must be flat. Use the template to set the centre of the fixing hole.

- Drill a 32mm (1.25") diameter mounting hole through the bulkhead.
- Remove the fixing nut. Peel the protective paper off the foam gasket and attach the gasket to the rear of the instrument.
- Insert the instrument through the bulkhead. Hand tighten the nut and then finally tighten with a spanner. Do not over tighten so that the water sealing ability of the gasket is damaged.

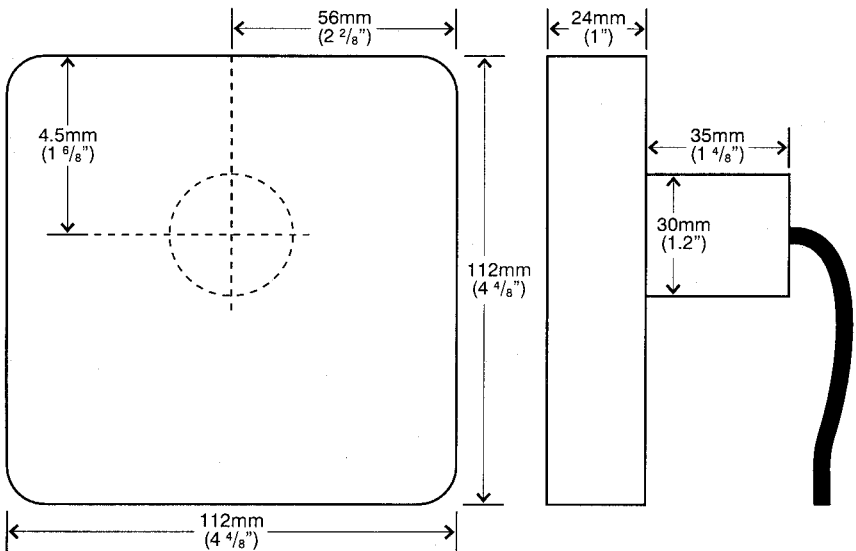

## Wiring Connection

- Keep electrical and transducer cables away from alternator or other noise generating electrical cables. Avoid connecting the instrument to power circuits that share loads with ignition, alternators, inverters and radio transmitters. Electrical power supply connections should always be as short as possible.

- Connect the red wire to the positive supply via a 1 amp fuse or a 1 amp circuit breaker. Connect the black wire to the electrical ground. A 1 amp fuse will provide protection for up to five 100 series instruments.
- Connect the 4 pin Fuji connector to the speed and temperature transducer cable connector. Extension cables are available if the transducer cable is too short.
- If you are not using a repeater or you do not intend to provide NMEA data to another instrument then insulate the bare wire end of the blue cable.

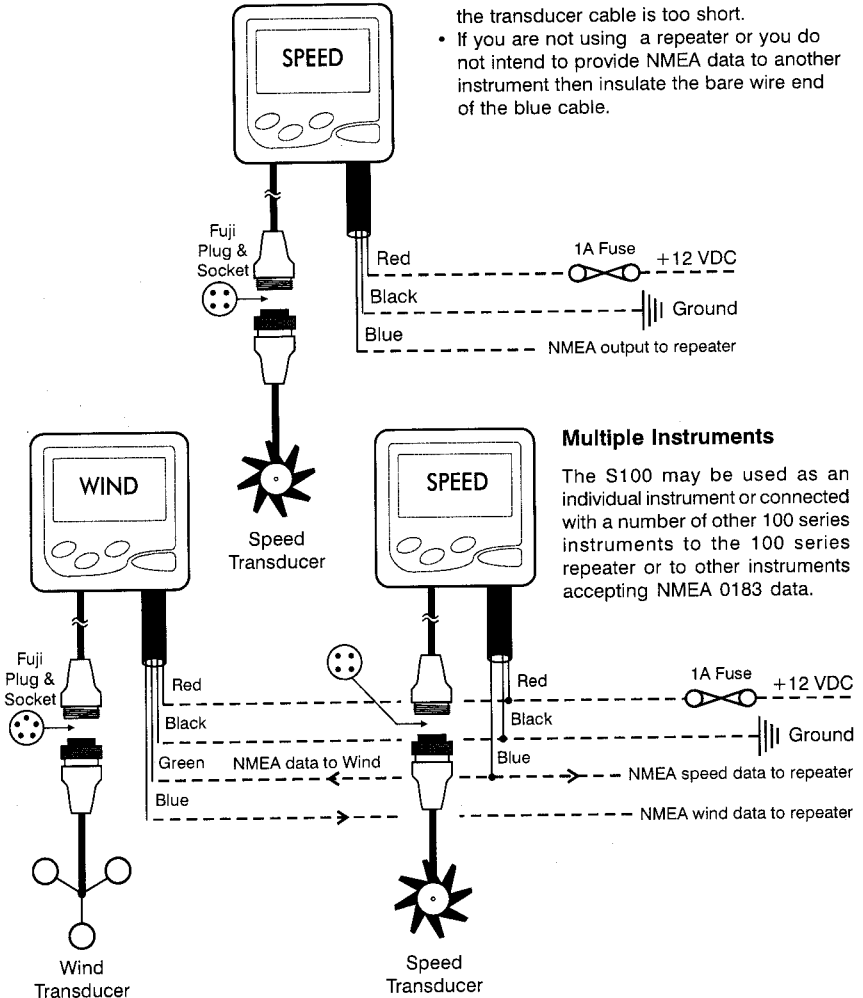

## Multiple Instruments

The S100 may be used as an individual instrument or connected with a number of other 100 series instruments to the 100 series repeater or to other instruments accepting NMEA 0183 data.

## Operation

### Function Select Keys

The  $\wedge$  or  $\vee$  keys are used to scroll through the main display functions of speed, average speed, log, total log and water temperature.

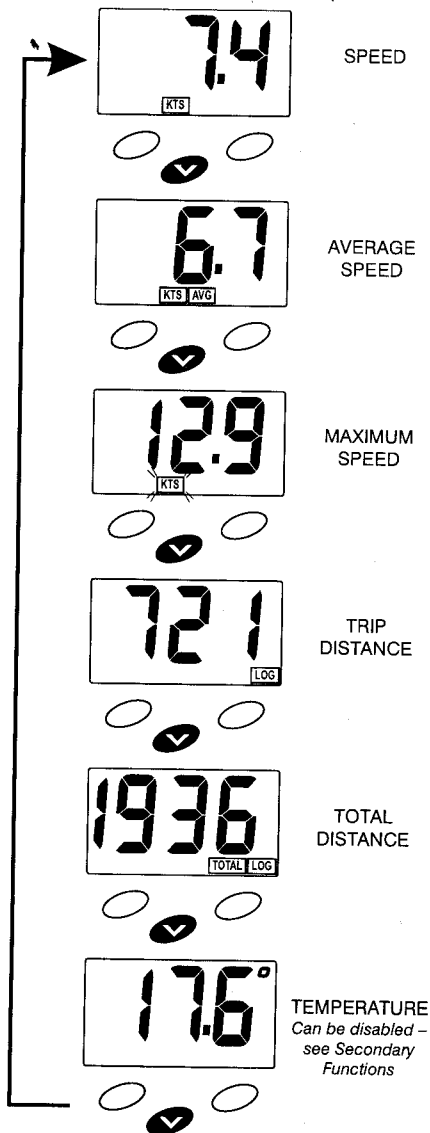

### Backlighting On / Off

Simultaneously press the  $\wedge$  and  $\vee$  keys to turn the backlight on. Repeat this procedure to turn the lighting off.

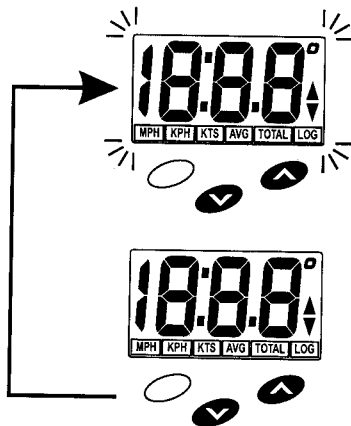

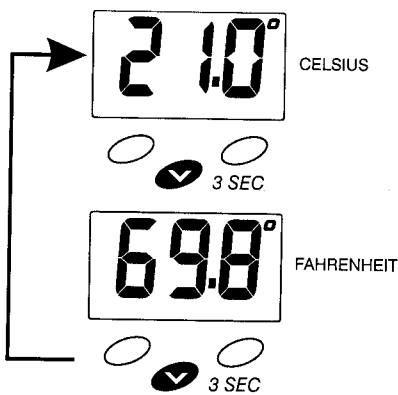

### Select Temperature Units

When the display is indicating temperature, press and hold the  $\wedge$  or the  $\vee$  key for three seconds to change the units of measure.





## Select Speed Units

While the unit is indicating speed press and hold the  or the  key for 3 seconds to change the units of measure.

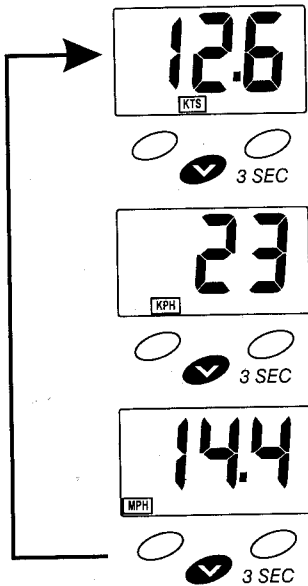

The three optional units are Knots (nautical miles per hour), MPH (statute miles per hour) or KPH (kilometers per hour).



## Reset Average Speed, Maximum Speed and Log

With the average speed, maximum speed or the log function displayed, press and hold the  and  keys for three seconds to reset displayed value to zero.

## Reset Total Log

With the total log value displayed, press and hold the  and  keys for fifteen seconds to reset the value to zero.

## Trend Indicator

There are two arrows on the display that will indicate an increasing or decreasing trend in boat speed. See the figure on page 1.





## Elapsed Timer

The elapsed timer will record time from power up. Time is displayed in hours and minutes up to 19 hours and 59 minutes.

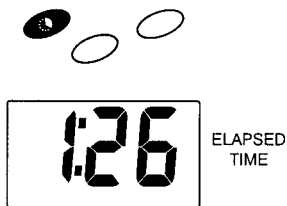
Press the  key to show elapsed time.



Press and hold the  and  keys for three seconds to reset the elapsed time to zero.

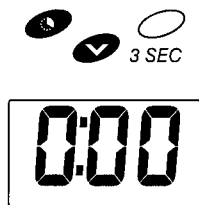

Press the  key to exit to the speed indicator.

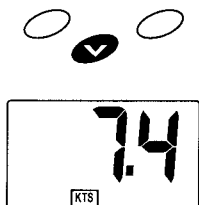

## Count Down Timers

There are two count down timers, one for 5 minutes and the other for 10 minutes. Audio beeps at 1 minute intervals from 4 minutes remaining to 1 minute remaining.

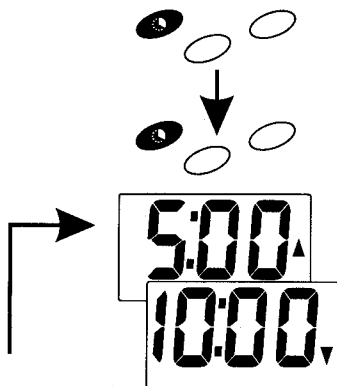

Press the  key twice to go into countdown timer mode.

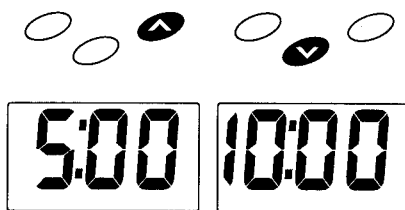

To start 5 minutes  
press the  key

To start 10 minutes  
press the  key



To reset the count down timer at any time, press and hold the  and  keys for three seconds.



The display will return to the timer selection.

## Secondary Functions

The secondary modes provide access to calibration of boat speed, calibration of sea temperature, speed display options of 1/10th or 1/100th units and to enable or disable the sea temperature function from the display sequence.

PRESS & HOLD FOR 3 SECONDS  
TO ENTER SECONDARY MODE

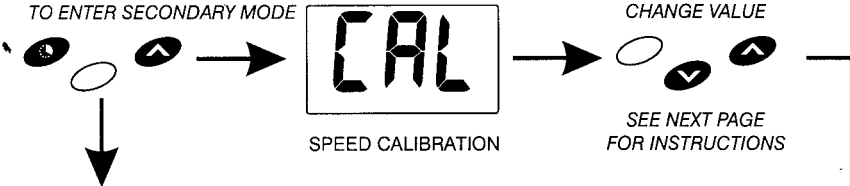

PRESS BOTH KEYS TO  
STEP TO NEXT FUNCTION

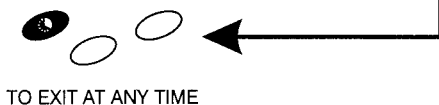
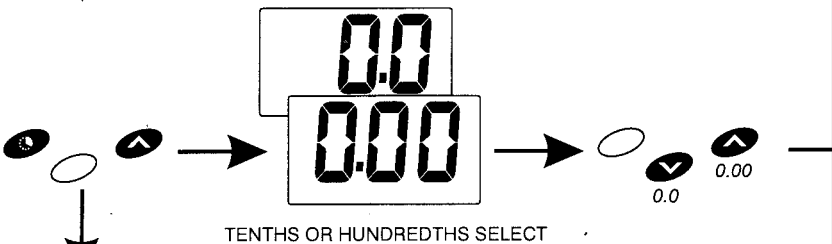
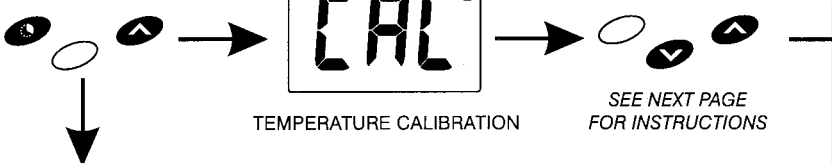
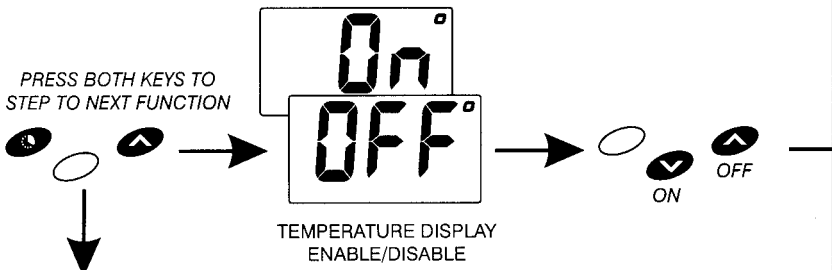

If no key is pressed for 10 seconds, the instrument will automatically exit secondary mode and return the display to normal. Changes made will not be saved.

## Calibrate Temperature Display

To adjust the temperature displayed.

Follow the chart on the left to reach Temperature Calibration mode.

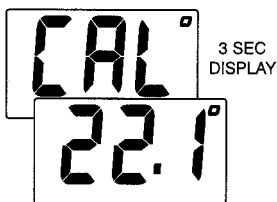

To increase reading press the  $\wedge$  key.

To decrease reading press the  $\vee$  key.

To enter the calibration setting into memory and exit press the  $\bullet$  key.

## Simulation Mode

The S100 has a simulation mode.

To enter this mode, hold down the  $\bullet$  key and then switch on the power. The instrument will remain in this mode even when power is switched off.

Repeat this procedure to exit simulation mode.

### **Note:**

*Settings that are made while in simulation mode will remain in effect after returning to normal mode.*

# Speed Calibration

## Speed Comparison Method

To adjust the speed displayed to match that of another craft or the speed displayed on a GPS receiver.

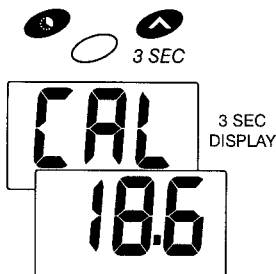

To increase reading press the  key.

To decrease reading press the  key.

To enter the calibration setting into memory and exit press the  key.

## Log Calibration Method

Set your log to zero and travel a known distance between two points. *If there is any tidal current, you should travel the same course in both directions to find the average distance.*

You may calculate a correction factor as follows:

$$\text{correction factor} = \frac{\text{Known distance}}{\text{distance from log}}$$

For example, if you have travelled over a known distance of 1 mile but your log reading is 0.8, giving a correction factor of 1.25. Therefore, your correct boat speed will be the indicated speed multiplied by 1.25.

Enter the simulation mode by holding the  key at power up. When speed is selected in the simulator mode the display will indicate a fixed calibration speed, for example 10.0 knots.

Follow the Secondary Functions chart to reach Speed Calibration mode.

Use the  to set the displayed speed to the new value. For our example, this new speed would be 10.0 x 1.25 which is 12.5 knots.

To enter the calibration setting into memory and exit press the  key.

To exit simulation mode, remove the power and then hold the  key at power up.

# Troubleshooting Chart

## No display:

Check DC power connections and DC polarity with voltmeter. Voltage must be between 10.7 and 16.6 volts.

## No speed reading:

1. Remove speed impellor from thru hull, spin paddlewheel manually and check for reading.
2. Check for fouling on paddle and thru hull.
3. Check for break in cable.

## Low or high speed reading:

1. Check calibration.
2. Inspect for damage to paddlewheel or fouling of fitting or paddle.

## Erratic speed reading:

1. Is there clear water flow over paddlewheel ?
2. Is paddlewheel aligned fore and aft correctly ?

## No, or inaccurate temperature reading:

1. Check calibration
2. Check for break in cable.

# S100 TEMPLATE

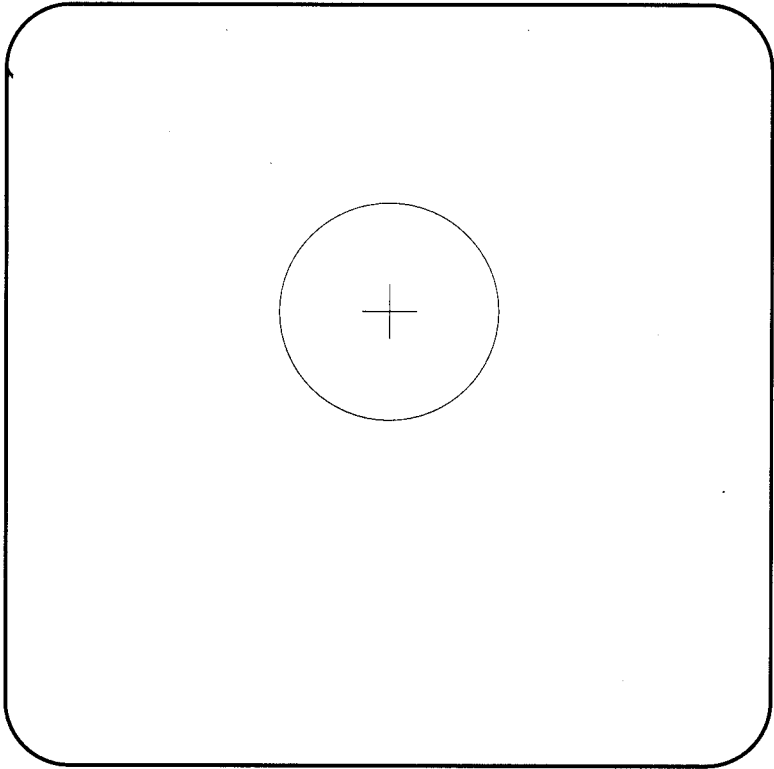

Photocopy this template and affix the copy to the surface before drilling

## ACCESSORY PART NUMBERS

267221	Panel Gasket
267247	Dust Cover
318800	15' Speed Ext Cable